

INSTALLATION MANUAL

## ID CPR60

### RFID Reader Module

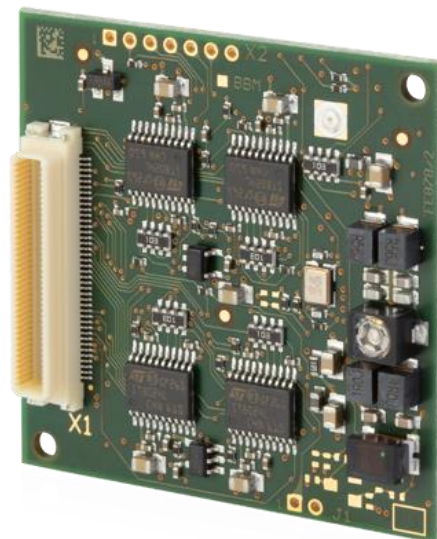

**Model**

**Article No.**

---

ID CPR60-A

5491.000.00

## Note

© Copyright 2022 by

FEIG ELECTRONIC GmbH  
Industriestraße 1a  
D-35781 Weilburg (Germany)  
Tel.: +49 6471 3109-0

[https://www.feig.de/en/  
identification-support@feig.de](https://www.feig.de/en/identification-support@feig.de)

With the edition of this document, all previous editions become void. Indications made in this manual may be changed without previous notice.

Copying of this document and giving it to others and the use or communication of the contents thereof are forbidden without express authority. Offenders are liable to the payment of damages. All rights are reserved in the event of the grant of a patent or the registration of a utility model or design.

Composition of the information in this document has been done to the best of our knowledge. FEIG ELECTRONIC GmbH does not guarantee the correctness and completeness of the details given in this manual and may not be held liable for damages ensuing from incorrect or incomplete information. Since, despite all our efforts, errors may not be completely avoided, we are always grateful for your useful tips.

The instructions given in this manual are based on advantageous boundary conditions. FEIG ELECTRONIC GmbH does not give any guarantee promise for perfect function in cross environments and does not give any guarantee for the functionality of the complete system which incorporates the subject of this document.

FEIG ELECTRONIC GmbH calls explicit attention that devices which are subject of this document are not designed with components and testing methods for a level of reliability suitable for use in or in connection with surgical implants or as critical components in any life support systems whose failure to perform can reasonably be expected to cause significant injury to human health. To avoid damage, injury or death the user or application designer must take reasonably prudent steps to protect against system failures.

FEIG ELECTRONIC GmbH assumes no responsibility for the use of any information contained in this document and makes no representation that they are free of patent infringement. FEIG ELECTRONIC GmbH does not convey any license under its patent rights nor the rights of others.

---

## Content

---

<b>1</b>	<b>Safety Instructions</b>	<b>4</b>
<b>2</b>	<b>Characterization ID CPR60</b>	<b>5</b>
<b>2.1</b>	<b>Available Accessories.....</b>	<b>5</b>
<b>2.2</b>	<b>Available Software Tools, USB Driver and Firmware.....</b>	<b>6</b>
<b>2.3</b>	<b>Development Board.....</b>	<b>6</b>
<b>3</b>	<b>Dimensions</b>	<b>7</b>
<b>4</b>	<b>Installation and wiring</b>	<b>8</b>
<b>4.1</b>	<b>Connector X1 .....</b>	<b>8</b>
<b>4.2</b>	<b>Connector ANT .....</b>	<b>11</b>
<b>5</b>	<b>Standby / Low Power Card Detection</b>	<b>12</b>
<b>6</b>	<b>Technical Data</b>	<b>13</b>
<b>7</b>	<b>Radio Approvals</b>	<b>15</b>
<b>7.1</b>	<b>Declaration of Conformity (CE) .....</b>	<b>15</b>
<b>7.2</b>	<b>Declaration of Conformity (UKCA) .....</b>	<b>15</b>
<b>7.3</b>	<b>USA (FCC) and Canada (IC) .....</b>	<b>16</b>
<b>8</b>	<b>ANNEX</b>	<b>18</b>
<b>8.1</b>	<b>Annex A: ID CPR60-DevBoard Reference Design .....</b>	<b>18</b>

---

## 1 Safety Instructions

- ▶ The device may only be used for the intended purpose designed by for the manufacturer.
- ▶ The operation manual should be conveniently kept available at all times for each user.
- ▶ Unauthorized changes and the use of spare parts and additional devices which have not been sold or recommended by the manufacturer may cause fire, electric shocks or injuries. Such unauthorized measures shall exclude any liability by the manufacturer.
- ▶ The liability-prescriptions of the manufacturer in the issue valid at the time of purchase are valid for the device. The manufacturer shall not be held legally responsible for inaccuracies, errors, or omissions in the manual or automatically set parameters for a device or for an incorrect application of a device.
- ▶ Repairs may only be executed by the manufacturer.
- ▶ Installation, operation, and maintenance procedures should only be carried out by qualified personnel.
- ▶ Use of the device and its installation must be in accordance with national legal requirements and local electrical codes.
- ▶ When working on devices the valid safety regulations must be observed.
- ▶ Before touching the device, the power supply must always be interrupted. Make sure that the device is without voltage by measuring. The fading of an operation control (LED) is no indicator for an interrupted power supply or the device being out of voltage!
- ▶ Special advice for wearers of cardiac pacemakers:  
Although this device doesn't exceed the valid limits for electromagnetic fields you should keep a minimum distance of 25 cm between the device and your cardiac pacemaker and not stay in the immediate proximity of the device's antenna for any length of time.

## 2 Characterization ID CPR60

The ID CPR60 is a RFID reader which supports ISO/IEC 14443 A/B and ISO 15693 contactless smart cards and transponders. It also offers 4 interfaces to connect ISO 7816 smart cards with contacts.

The reader is designed to connect an external individual RFID antenna to the 50 Ohm antenna output. For operation in USA and Canada approved antennas are permitted only (see [USA \(FCC\) and Canada \(IC\)](#)).

Optional the RFID interface can support the contactless standards ISO18000-3M3 and NFC Peer-to-Peer (P2P; Passive Initiator Mode) in accordance with ISO/IEC 18092. This support is available on request only.

For host communication ID CPR60 offers an USB device full speed interface, an RS232-LVTTL interface (COM Interface) and an SPI interface. For data transfer with a host computer the ISOHost mode (polling) is available via the USB, COM and SPI interface.

The functionality of the ID CPR60 is based on the well known CPR-family, like the reader module ID CPR74 or the wall-mount reader ID CPR50.10 and is compatible with them mainly.

The use of ISOHost commands guarantees an easy creation of user software as well as the compatibility with all other FEIG RFID readers.

Beside the CPRStart software for demonstration and configuration of the reader capabilities and the Firmware Update Tool a lot of different Software Development Kits (SDK) and drivers are available to support an easy integration into the customer's application.

### 2.1 Available Accessories

Tab. 1 Available Accessories and spare parts

Part Number	Part name	Description
5604.000.00	ID CPR60-DevBoard	Development Board for the ID CPR60 incl. Power Supply with European plug
3674.000.00	ID ISC.ANT40/30-U.FL-A	50 Ohm Antenna with U.FL-connector for the connection to the ID CPR60 Dimensions: 40 mm x 30 mm
3673.000.00	ID ISC.ANT100/100-U.FL-A	50 Ohm Antenna with U.FL-connector for the connection to the ID CPR60 Dimensions: 100 mm x 100 mm
3540.000.00	ID ISC.ANT.C05-A	50 Ohm antenna cable with U.FL connector on both sides for the connection of an external antenna to the ID CPR60 Dimension : 500 mm; Color: black

## 2.2 Available Software Tools, USB Driver and Firmware

The USB driver and the test and configuration tool “CPRStart” are available on our FEIG download area:

<https://www.feig.de/en/login>

Username: CPR60

Password : cpr\_reader

For firmware updates we are providing the “FirmwareUpdateTool” and a external firmware xml-file.

## 2.3 Development Board

For demonstration and development purposes a special PCB with connectors, smart card connectors, power supply and antenna is available on request (see [Available Accessories](#)).

The ID CPR60-DevBoard offers 3 SAM sockets for ID-000 smart cards, 1 smart card connector for full size ID 1 cards and different connectors for the USB, COM and SPI interface. The integrated antenna can be used in combination with the CPR60 to communicate with transponders.

Different multi-pin connectors offer the possibility to measure and analyse signals on the different interfaces and connectors.

The DevBoard will be delivered including a power supply. A suitable reader ID CPR60 must be ordered separately.

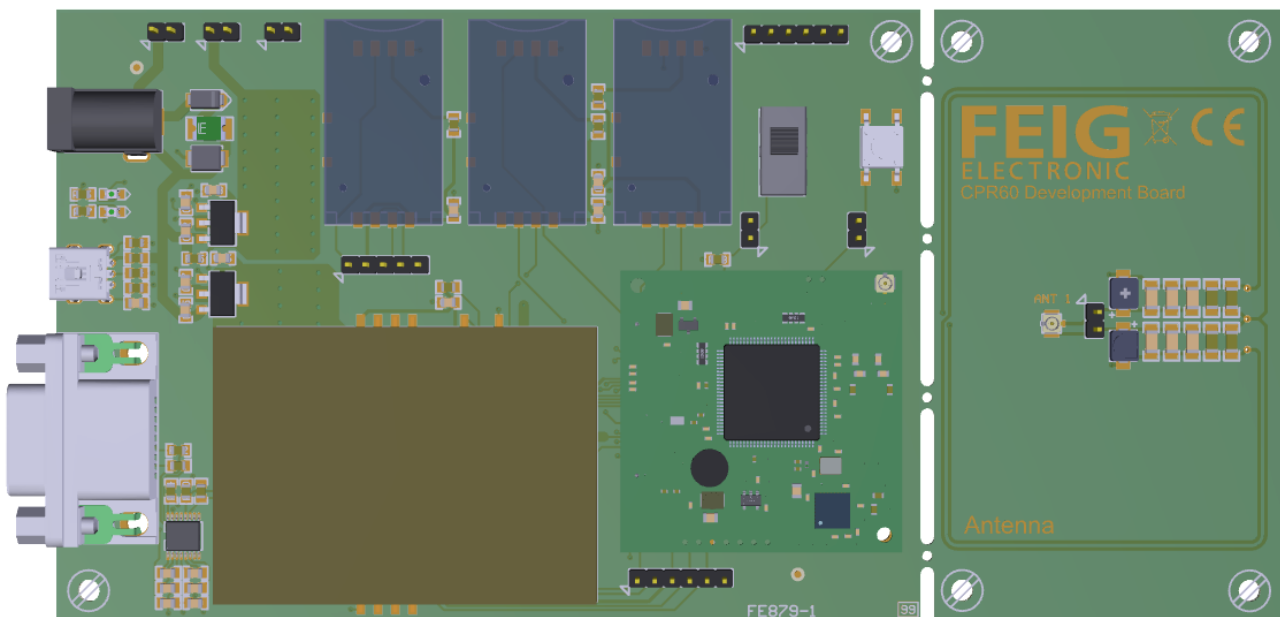

Further information about the ID CPR60-DevBoard can be found in [Annex A: ID CPR60-DevBoard Reference Design](#).

### 3 Dimensions

The ID CPR60 reader module has been designed for the integration into terminals, printers or handheld devices and so on.

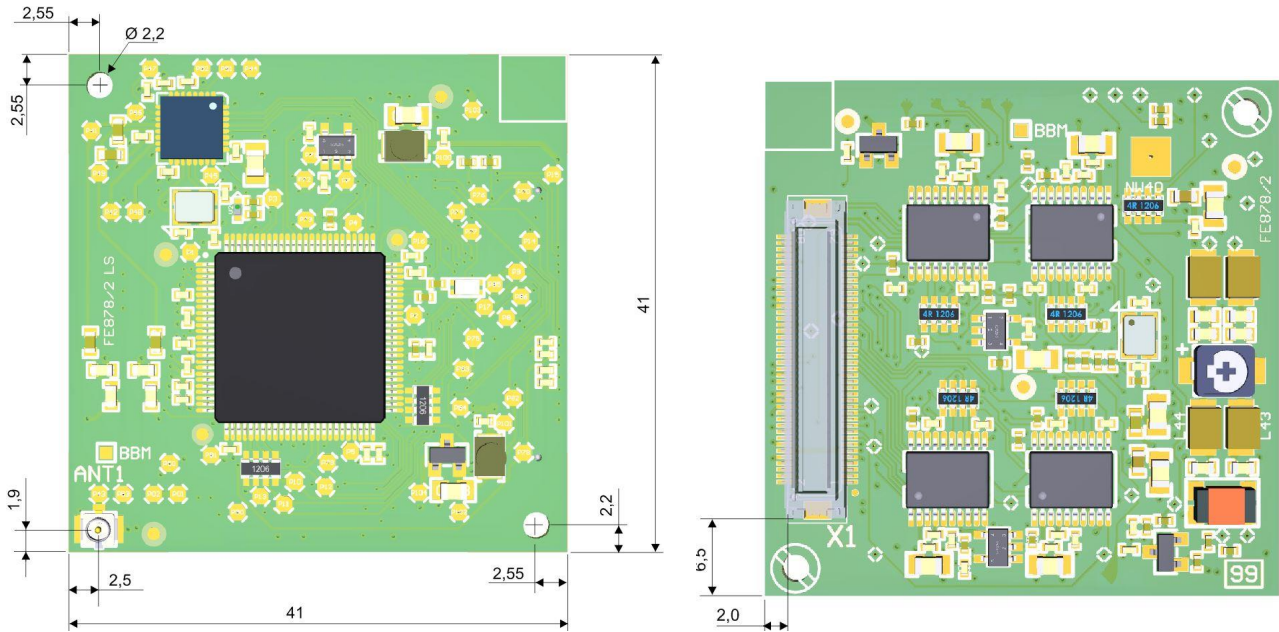

Figure 1: Dimension (Top View)

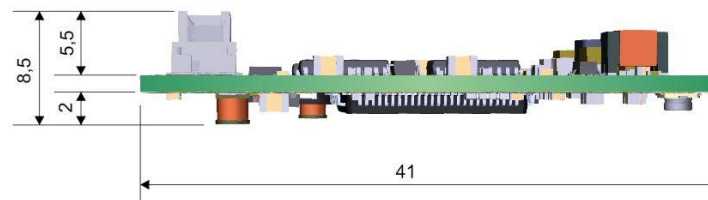

Figure 2: Dimension (Side View)

## 4 Installation and wiring

### 4.1 Connector X1

X1 (Connector Type: Hirose DF17(2.5)-80DP-0.5V(57)) is the main connector for power supply, interfaces and control signals. The following table shows the pin-assignment of the connector. Interfaces and functions are described from the ID CPR60 view (an input must be connected to one output or vice versa).

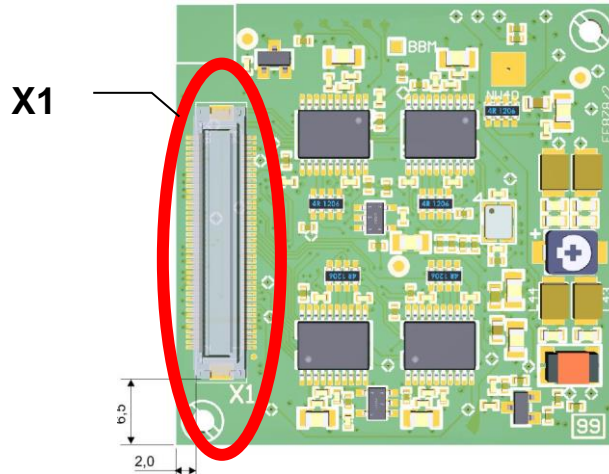

Figure 3: Connector X1

At connector X1 four external smart card connectors can be connected. SAM1, SAM2, SAM3 and KCC whereas only KCC supports a card presence signal, which also can be used to awake the CPR60 from standby mode (see:



[Standby / Low Power Card Detection](#)).

PIN	Function	Remark	PIN	Function	Remark
1	n.c.		2	n.c.	
3	n.c.		4	n.c.	
5	n.c.		6	n.c.	
7	n.c.		8	n.c.	
9	GND		10	GND	
11	3,3 V DC Supply		12	3,3 V DC Supply	
13	3,3 V DC Supply		14	GND	
15	SAM3_CLK		16	n.c.	
17	KCC_CLK (SAM4)		18	n.c.	
19	SAM1_I/O		20	n.c.	
21	SAM2_I/O		22	n.c.	
23	SAM3_I/O		24	n.c.	
25	KCC_I/O (SAM4)		26	SAM1_VCC	
27	n.c.		28	SAM2_VCC	
29	n.c.		30	SAM3_VCC	
31	n.c.		32	GND	
33	n.c.		34	KCC_VCC (SAM 4)	
35	GND		36	SAM1_CLK	
37	SPI_MISO*	CPR60 is Slave	38	SAM2_CLK	
39	SPI_MOSI*	CPR60 is Slave	40	USB DP*	
41	SPI_nCS**	CPR60 Input	42	USB DM*	
43	SPI_CLK**	CPR60 Input	44	n.c.	
45	n.c.		46	n.c.	
47	SAM1_RST		48	n.c.	
49	SAM2_RST		50	nKCC_DET (SAM 4)	Smartcard present connector input  0: Card preset 1: Card no present

PIN	Function	Remark	PIN	Function	Remark
51	SAM3_RST		52	nLOW_PWR	Control input for low power card detection  0: low power mod low 1: normal mode
53	KCC_RST (SAM 4)		54	n.c.	
55	GND		56	n.c.	
57	n.c.		58	GND	
59	n.c.		60	5 V DC Supply	
61	n.c.		62	n.c.	
63	n.c.		64	nRESET	Reset Input
65	RS232_TxD	reader TxD, host RxD	66	RS232_RxD*	Reader RxD, Host TxD
67	n.c.		68	n.c.	
69	n.c.		70	n.c.	
71	n.c.		72	SPI_INT	IRQ output with double function:  <ul style="list-style-type: none"> <li>• SPI-IRQ</li> <li>• Low power card detection: Card detected</li> </ul>
73	n.c.		74	n.c.	
75	GND		76	GND	
77	n.c.		78	n.c.	
79	n.c.		80	n.c.	

\* 5 V tolerant Input

\*\* 3,3 V tolerant Input

## 4.2 Connector ANT

The ID CPR60 module is equipped with a connector for an external 50  $\Omega$ -antenna. The connection of the external antenna is possible via the U.FL connector „ANT“.

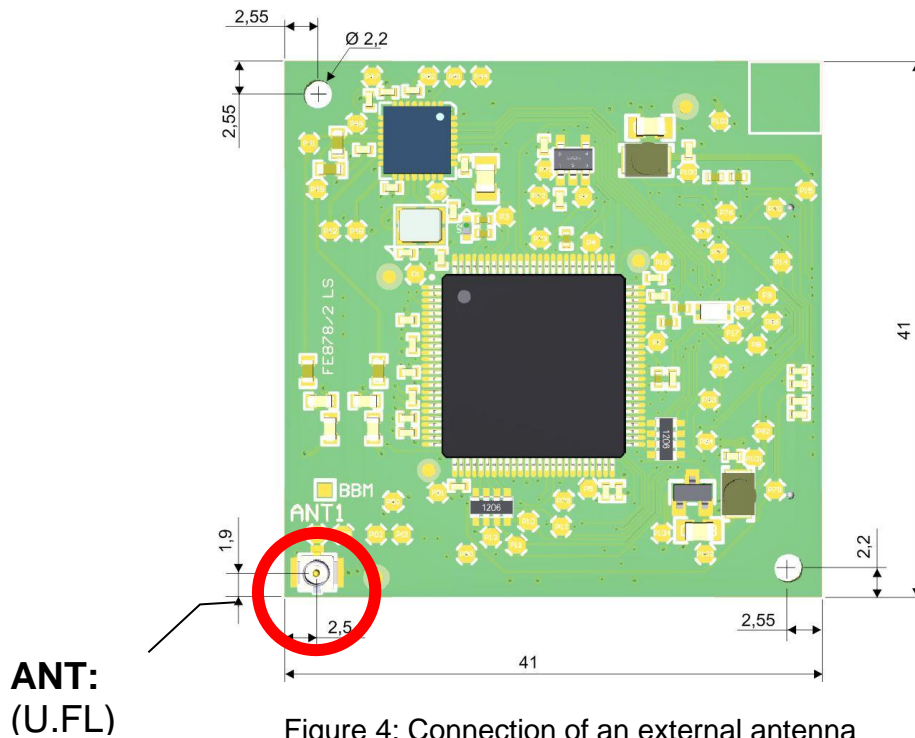

The technical description and hints for building external 50  $\Omega$ -antennas can be taken from the application note N20901-#d-ID-B.pdf.

### NOTICE:

- Only for use with 50  $\Omega$  matched external antennas. The permanent usage of unmatched antennas can damage the reader electronic.
- The antenna output is neither permanent short circuit protected nor permanent no-load protected.
- The antenna cable should be no longer than 1m. The use of other cable length are possible after consulting the manufacturer.

## 5 Standby / Low Power Card Detection

The ID CPR60 offers a standby mode to reduce the power consumption to a minimum. The standby mode can be controlled by the host via input nLOW\_PWR (see: [Connector X1](#)).

The standby mode is activated if input nLOW\_PWR is set to low. In this mode the reader wakes up if:

- a contactless card is detected in front of the RFID antenna or
- if the Input nKCC\_DET is set to 0

The reader remains active for a configurable time. Even if nLOW\_PWR is set to high during this time the reader remains active as long as nLOW\_PWR is set to high.

The host can switch the reader at any time back into the standby mode with command [0x64] System Reset.

## 6 Technical Data

Tab. 2: Technical data

		ID CPR60
Dimension (W x H x D)		max. 41 mm x 41 mm x 6,5 mm
Weight		approx. 10 g
Temperature Range	Operating	-25 °C up to +70 °C (-13 °F up to +158 °F)
	Storage	-40 °C up to +85 °C (-40 °F up to +185 °F)
Humidity		max. 95 % (not condensing)
Power Supply <sup>1</sup>		<ul style="list-style-type: none"> <li>for digital circuit: 3,3 V DC ± 5 % max power consumption: 100 mA</li> <li>for analog circuit: 5 V DC ± 5 % Ripple: 0...250 kHz &lt; 10 mVpp up from 250 kHz &lt; 0,1 mVpp max power consumption peak (excl. SAM): 300 mA typ. power consumption with RFID (excl. SAM): 200 mA</li> </ul>
Current Consumption		< 400 mA (without SAM) < 25mA Standby mode < 50mA Standby Mode with Wake-Up-by-Card
Interfaces	USB	Full-Speed (12 Mbit/s), Self-Powered Device
	SPI	Slave Device (up to 16 Mbit/s)
	RS232-LVTTL	4 800 – 921 600 Baud
Driver		USB Driver, PC/SC-Driver (WHQL) Windows 7, 8 and 10 32/64 Bit Windows Server 2012 and 2016
Connector (Vcc, USB , SPI, Smart Card)		80 pole Board-to-Board (see: <a href="#">Connector X1</a> )
Software Development Kits		Windows (C++, .NET, Java), Linux (C++, Java), Raspberry Pi
RFID Interface		ISO/IEC 14443-A/-B (ISO-Mode: 106, 212, 424, 848 kbit/s; EMVCo Mode: 106 kbit/s)  ISO 15693
Operating Frequency		13,56 MHz
Output Power		typ. 450 mW
Antenna Connection		U.FL-Socket for external 50 Ohm antenna

<sup>1</sup> The reader has to be supplied by a limited power supply according to EN 62368-1 PS1.

<b>Contact Interface (ISO 7816)</b>		4 SAM card interfaces T=0 and T=1 Protocol, Power Class A, B & C
<b>Operating Modes</b>		ISOHost Mode (Polling Mode)
<b>Radio Approval</b>	<b>Europe</b>	EN 300 330
	<b>UK</b>	EN 300 330
	<b>USA</b>	FCC - Title 47 CFR Part 15 RSS-210 Issue 10
	<b>Canada</b>	RSS-Gen Issue 5 incl. Amendment 1
<b>EMV</b>		EN 301 489
<b>Safety and Health</b>		EN 62368-1 EN 50364
<b>Waste and Hazardous Substances</b>		WEEE - 2002/96/EC RoHS - 2011/65/EC

## 7 Radio Approvals

### 7.1 Declaration of Conformity (CE)

	<p><b>Declaration of Conformity (CE)</b></p> <p>Hereby, FEIG ELECTRONIC GmbH declares that the radio equipment type ID CPR60 is in compliance with Directive 2014/53/EU.</p> <p>The full text of the EU declaration of conformity is available at the following internet address:</p> <p><a href="https://www.feig.de/en/service/eu-declarations-of-conformity/">https://www.feig.de/en/service/eu-declarations-of-conformity/</a></p>
-----------------------------------------------------------------------------------	----------------------------------------------------------------------------------------------------------------------------------------------------------------------------------------------------------------------------------------------------------------------------------------------------------------------------------------------------------------------------------------------------------------------------------------

### 7.2 Declaration of Conformity (UKCA)

	<p><b>UKCA Declaration of Conformity</b></p> <p>Hereby FEIG ELECTRONIC GmbH declares that the radio equipment type ID CPR60 is in compliance with Directive No. 1206 Radio Equipment Regulations 2017.</p> <p>The full text of the UKCA declaration of conformity is available at the following internet address:</p> <p><a href="https://www.feig.de/en/service/ukca-declarations-of-conformity/">https://www.feig.de/en/service/ukca-declarations-of-conformity/</a></p>
-----------------------------------------------------------------------------------	----------------------------------------------------------------------------------------------------------------------------------------------------------------------------------------------------------------------------------------------------------------------------------------------------------------------------------------------------------------------------------------------------------------------------------------------------------------------------

### 7.3 USA (FCC) and Canada (IC)

<b>Product name:</b>	<b>ID CPR60</b>
<b>FCC ID:</b> <b>IC:</b>	<b>PJMCPR60</b> <b>6633A-CPR60</b>
<b>Notice for USA and Canada</b>	<p>This device complies with Part 15 of the FCC Rules and with RSS-210 of Industry Canada.  Operation is subject to the following two conditions.  (1) this device may not cause harmful interference, and  (2) this device must accept any interference received, including interference that may cause undesired operation.  Unauthorized modifications may void the authority granted under Federal communications Commission Rules permitting the operation of this device.  This equipment has been tested and found to comply with the limits for a Class A digital device, pursuant to Part 15 of the FCC Rules. These limits are designed to provide reasonable protection against harmful interference when the equipment is operated in a commercial environment. This equipment generates, uses, and can radiate radio frequency energy and, if not installed and used in accordance with the instruction manual, may cause harmful interference to radio communications. Operation of this equipment in a residential area is likely to cause harmful interference in which case the user will be required to correct the interference at his own expense.</p> <p>Le présent appareil est conforme aux CNR d'Industrie Canada applicables aux appareils radio exempts de licence. L'exploitation est autorisée aux deux conditions suivantes :</p> (1) l'appareil ne doit pas produire de brouillage, et (2) l'utilisateur de l'appareil doit accepter tout brouillage radioélectrique subi, même si le brouillage est susceptible d'en compromettre le fonctionnement.

**Warning: Changes or modification made to this equipment not expressly approved by FEIG ELECTRONIC GmbH may void the FCC authorization to operate this equipment.**

#### **Installation with FCC / IC Approval:**

The reader module was tested according to the standard FCC - Title 47 CFR Part 15 §207, §209 and §225 and the ISED standard RSS 210 Issue 10 and RSS Gen Issue 5 . The module is conform to the listed limits in the standards.

In normal operation the RF exposure is far below the limits of OET Bulletin 65.

This module is approved for installation into fixed and/or mobile host platforms and must not be co-located or operating in conjunction with any other antenna or transmitter except in accordance with FCC/ISED multi-transmitter guidelines. End users must be provided with transmitter operating conditions for satisfying RF Exposure compliance.

The manufacturer is obliged to include a notice "Contains FCC ID: PJMCPR60 and IC: 6633A-CPR60" at the user manual and on the product label.

The manufacturer is obliged to test the terminal device together **with** the reader module according to the national FCC requirements according to 47 CFR Part15 §209 and §225 For this purpose the reader module must be set to normal operation, ScanMode. The Scan mode is switched on by SW command: Transparent Command - Extended Inventory (all Antenna) HEX: 02 00 0A FF B0 01 40 FF.



The manufacturer is obliged to test the terminal equipment **without** RF transmitter, according to the national FCC requirements according to 47 CFR Part 15 Subpart B. For this purpose, the HF transmitter of the reader module must be switched off. The HF transmitter is switched off by the SW command: Transparent Command - HF Off HEX: 06 FF 6A 00

FCC-/IC-NOTICE: To comply with FCC Part 15 Rules in the United States / with IC Radio Standards in Canada, the system must be professionally installed to ensure compliance with the Part 15 certification / IC certification. It is the responsibility of the operator and professional installer to ensure that only certified systems are deployed in the United States / Canada.

### **Antennas Approved in the USA (FCC) and Canada (IC)**

Following antennas are approved by FCC according FCC Part 15 and IC Canada according RS210:

- ID ISC.ANT100/100 (100 mm x 100mm)
- ID ISC.ANT40/30 (40 mm x 30mm)
- RFID Antenna Board 445-100302 (30 mm x 30mm)

A coaxial cable, U.FL-LP-088, is used to connect the antenna. The antenna cable should be no longer than 1,0 m. The use of other cable length are possible after consulting the manufacturer.

## 8 ANNEX

### 8.1 Annex A: ID CPR60-DevBoard Reference Design

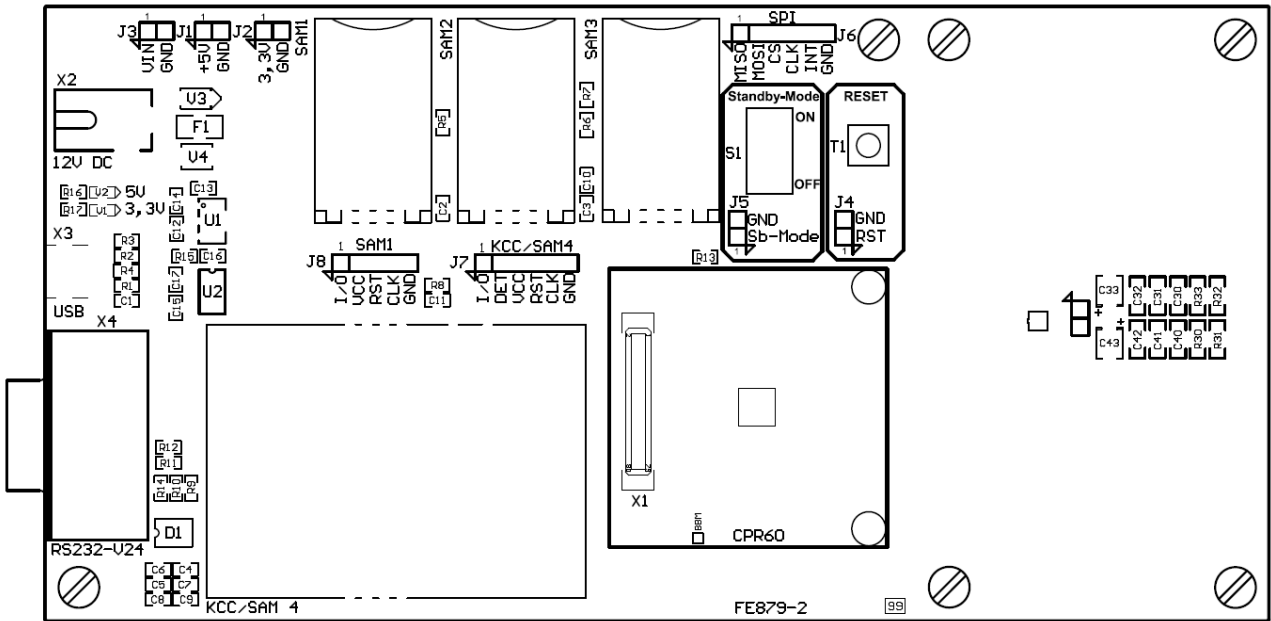

Figure 5: Top Overlay Print

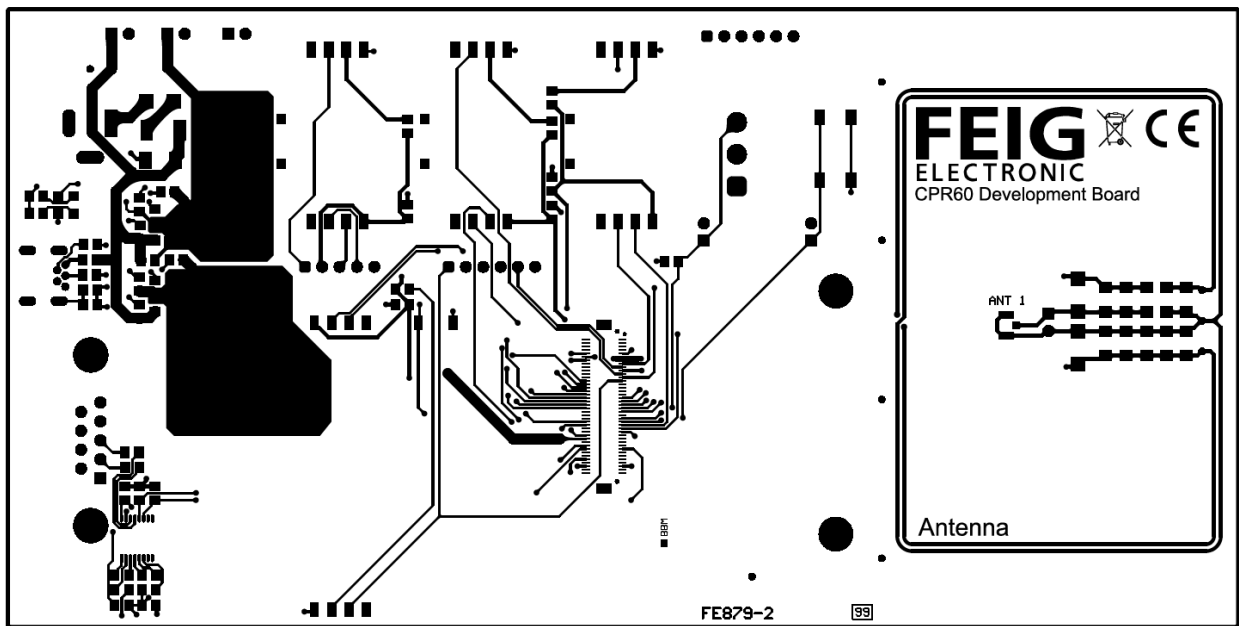

Figure 6: Top Layer

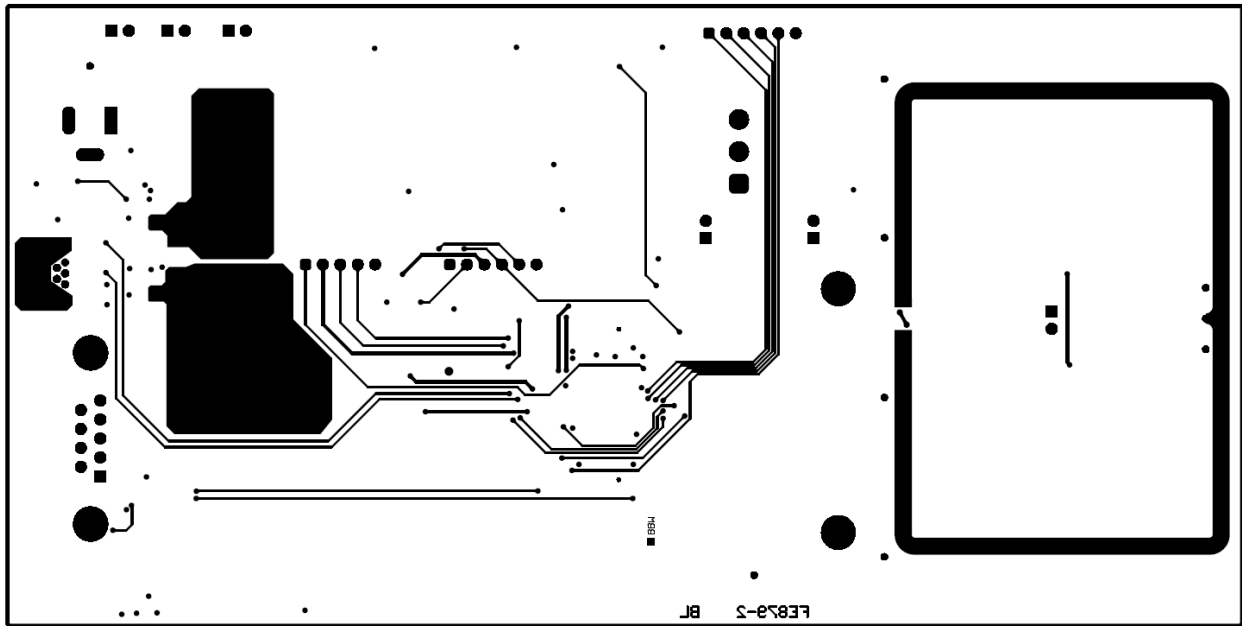

Figure 7: Bottom Layer

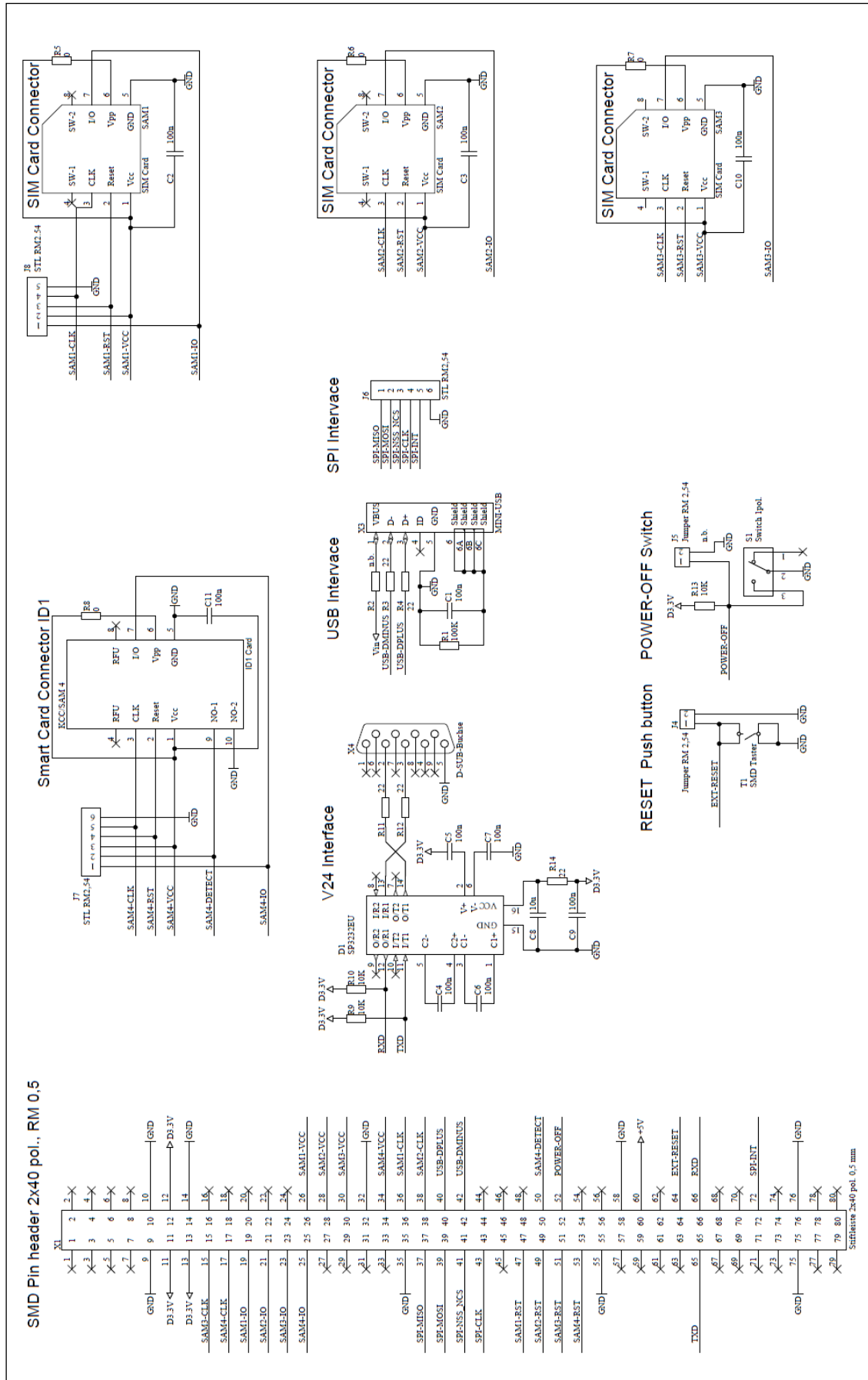

Figure 8: CPR60-DevBoard Schematic Part 1

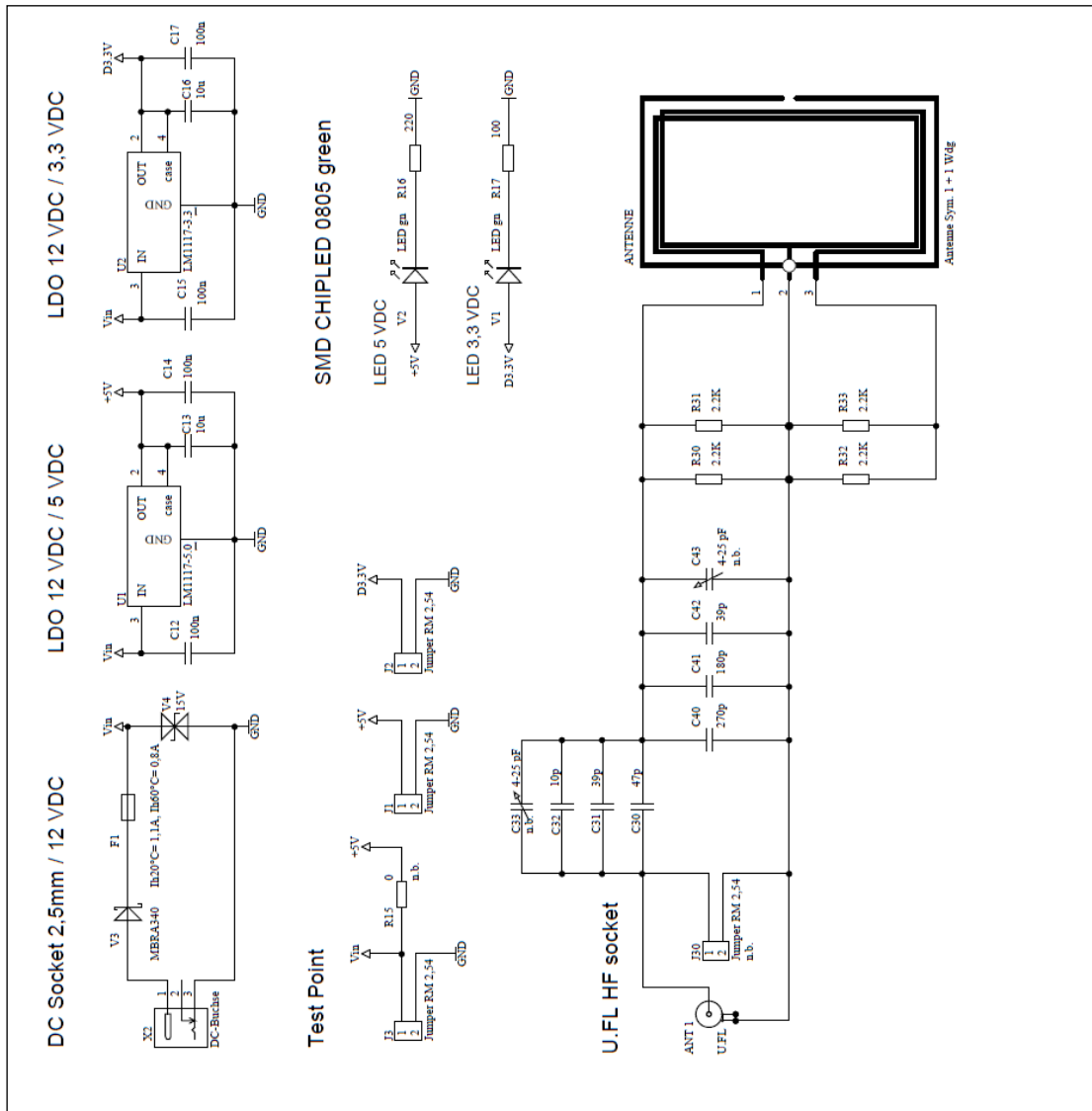

Figure 9: CPR60-DevBoard Schematic Part 2

Tab. 3: Bill of Material CPR60-DevBoard

Symbol	Description
ANT 1	SMD U.FL HF-Print socket
C1, C2, C3, C4, C5, C6, C7, C9, C10, C11, C12, C14, C15, C17	SMD capacitor 100.000pF/50V
C30	SMD capacitor 47pF/200V
C31, C42	SMD capacitor 39pF/200V
C32	SMD capacitor 10pF/200V
C40	SMD capacitor 270pF/200V
C41	SMD capacitor 180pF/200V
C8, C13, C16	SMD capacitor 10µF/10V
D1	SMD SP3232EU RS232 Transceiver
F1	SMD POLYSWITCH RESETTABLE IH20°C= 1,1A, IH60°C= 0,8A
J1, J2, J3, J4, J5	Pin header 2 poles, RM2,54, Horizontal
J6, J7	Pin header 6 poles, RM2,54, Horizontal
J8	Pin header 5 poles, RM2,54, Horizontal
KCC/SAM 4	SMD Smart Card Connector ID1, 8 Pin
R1	SMD resistor 100K0 0,125W
R16	SMD resistor 220R0 0,125W
R17	SMD resistor 100R0 0,125W
R3, R4, R11, R12, R14	SMD resistor 22R0 0,125W
R30, R31, R32, R33	SMD resistor 2K2 0,25W
R5, R6, R7, R8	SMD resistor 0R0 0,125W
R9, R10, R13	SMD resistor 10K0 0,125W
S1	Switch 1pol. SPDT
SAM1, SAM2, SAM3	SMD SIM Card Connector CH03-BH060-AA
T1	SMD Push button 6x6mm, 160N
U1	SMD LDO LM1117-5, 5V/800mA
U2	SMD LDO LM1117-3,3V, 800mA
V1, V2	SMD CHIPLED 0805 green
V3	SMD Schottky Power Rectifier MBRA340T3 SMA
V4	SMD Transient Voltage Suppressor 15V, bidir., 600W
X1	SMD Pin header 2x40 pol., RM 0,5
X2	DC Socket 2.5mm
X3	Mini USB - B Socket, Horizontal
X4	D-Sub. 9pol. Socket, Snap-in, 90° right angle