

NOTE SOLDER TO HEADER OR USE "AMP" 6 POSITION CONNECTOR PART No. 1-87499-1 AND SIX PINS PART No. 102917-2, OR EQUIVALENT.

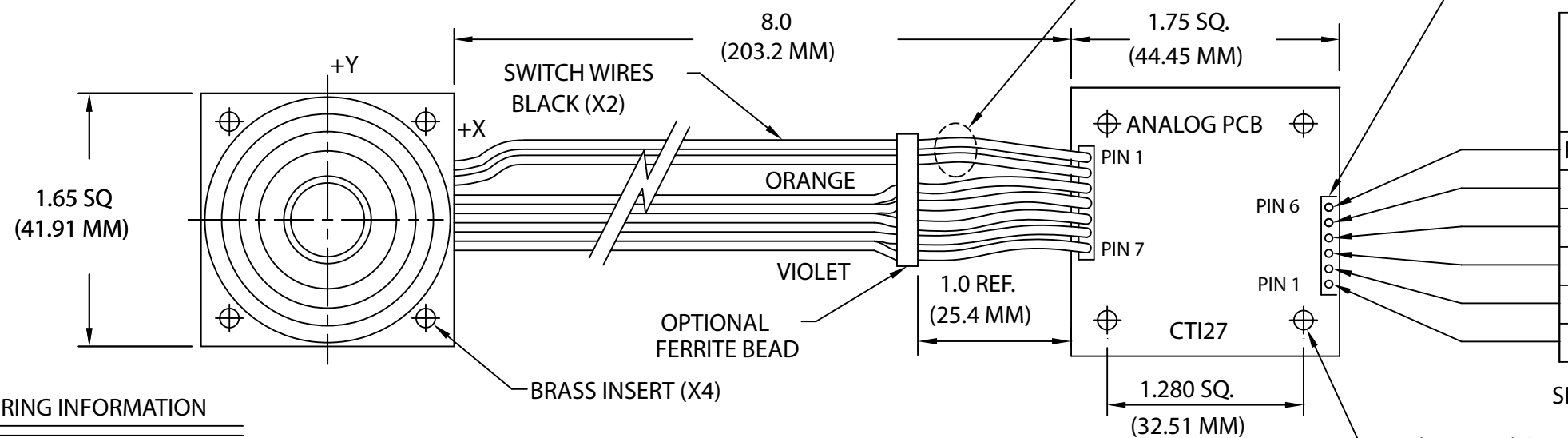

F1000	F1020	F1030	F1010 F1040 F1050	F1060
PUSH BUTTON SWITCH OR OPTIONAL NEUTRAL SWITCH				
Y OUT	Y OUT	Y OUT	Y OUT	Y OUT
V REF.	COMMON	COMMON	V REF	COMMON
X OUT	X OUT	X OUT	X OUT	X OUT
COMMON	-5V	-12V	COMMON	-10V
+12V	+5V	+12V	+5V	+10V

SPECIFICATIONS SUBJECT TO CHANGE WITHOUT NOTICE

ORDERING INFORMATION

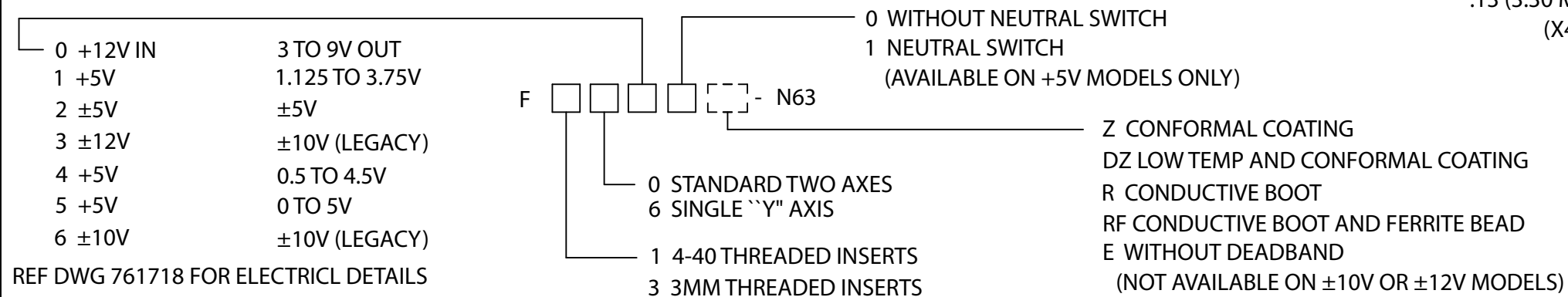

CTI ELECTRONICS CORPORATION
WWW.CTIELECTRONICS.COM

NEMA 4 (IP66)
INDUSTRIAL JOYSTICK
(ANALOG) F1000-N63 SERIES

761780

APPROVED

SHEET 1 OF 1
DATE 11-21-13

REV. C
DRAWN BY
PSB