



Ingeniería Electrónica  
*SMART IDENT*

---

CDC-1000  
CARD ISSUING/COLLECTING MACHINE  
EVOLUTION 2018  
User Manual

---

<b>Doc No</b>	<b>CDC1000 SPECIFICATION</b>	<b>REV</b>	<b>PAGE</b>	<b>DATE</b>
		C	2 OF 51	2018. 11. 8

REVISION HISTORY

No	DATE	DESCRIPTION	REV	PAGE	F/W Name
1	2016.10.28.	First Edition	A	38	
	2018.09	Modified the drawing	B	39	
	2018.11	Added the C39 command	C	39	

<b>Doc No</b>	<b>CDC1000 SPECIFICATION</b>	<b>REV</b>	<b>PAGE</b>	<b>DATE</b>
		C	3 OF 51	2018. 11. 8

## MODEL NAME INFORMATION

C D C - 1 X X X X

	FUNCTION	MS/IC/RF	CAPACITY	INTERFACE	OPTION
Card Issue & Collector Machine	1: SINGLE STACKER	0: RF Only 1: IC Only 2: MS Read Only (Triple Track) 3: MS+IC 4: MS+RF 5: IC+RF 6:MS+IC+RF	1:100 2:- 3:300  0.76 Thickness Only.	1: RS-232C 2: USB	0: Without bezel 1: Short bezel

<b>Doc No</b>	<b>CDC1000 SPECIFICATION</b>	<b>REV</b>	<b>PAGE</b>	<b>DATE</b>
		C	4 OF 51	2018. 11. 8

## **C O N T E N T S**

**Overview**

**System Block Diagram**

**Specification**

**Magnetic Card Process**

**IC Card Process**

**Communication Interface**

**Technical Drawing**

**Command Detail**

**Error Detail**

**Precautions**

<b>Doc No</b>	<b>CDC1000 SPECIFICATION</b>	<b>REV</b>	<b>PAGE</b>	<b>DATE</b>
			C	5 OF 51

## **OVERVIEW**

CDC-1000 Series is a set of card issuing machine for the magnetic and IC card in conjunction with the CDC Dispenser and KST3000 series. This model can be used for magnetic card conforming to the ISO7816-2 standard and most of the IC cards conforming with the ISO7816-4 T=0.

This model simplified the command for magnetic card, minimize the delay time occurs in the communication data processing, and improved the speed due to function to issue the all tracks at a time.

As an automatic issuing machine, this model can be used in issuing most types of credit card and debit card in financial area.

<b>Doc No</b>	<b>CDC1000 SPECIFICATION</b>	<b>REV</b>	<b>PAGE</b>	<b>DATE</b>
		C	6 OF 51	2018. 11. 8

## SYSTEM BLOCK DIAGRAM

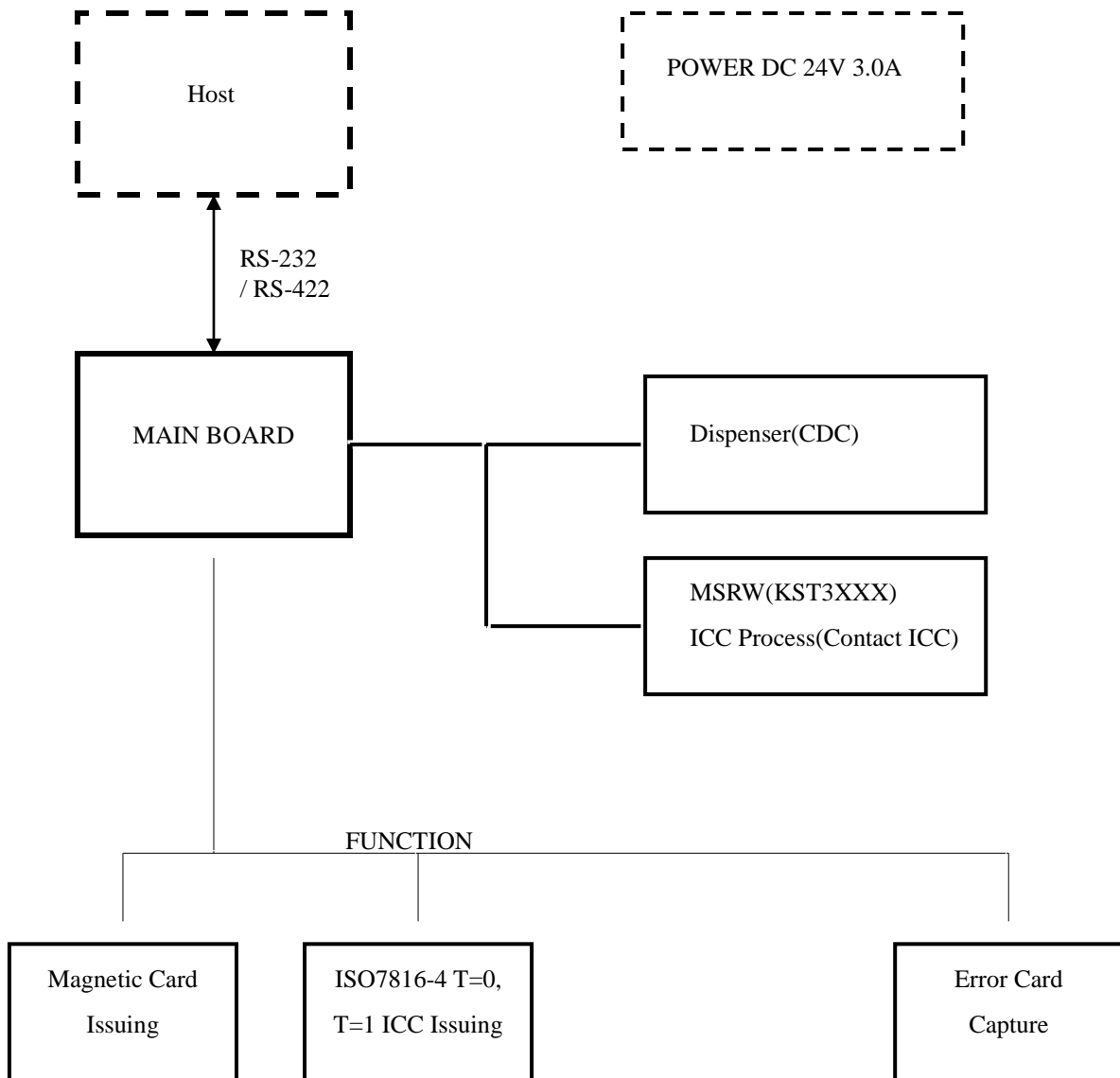

<b>Doc No</b>	<b>CDC1000 SPECIFICATION</b>	<b>REV</b>	<b>PAGE</b>	<b>DATE</b>
		C	7 OF 51	2018. 11. 8

◆ *RS – 232 Connection*

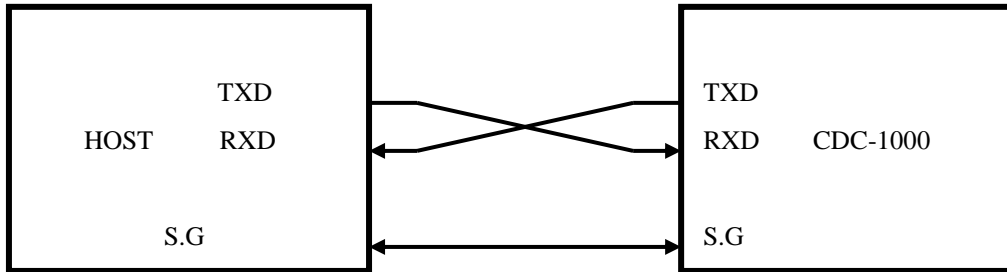

CASE 1) Part Number : D-SUB CONNECTOR(FEMALE)

Pin No	INDEX	Remark
2	RXD	Receive
3	TXD	Transmit
5	S.G	Signal Ground

◆ *RS422 Connection*

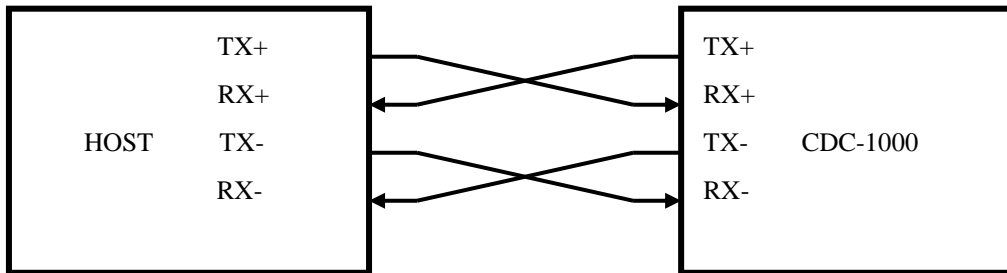

CASE 1) Part Number : D-SUB CONNECTOR(FEMALE)

Pin No	INDEX	Remark
1	TX+-	
4	RX+	
6	TX-	
8	RX-	

<b>Doc No</b>	<b>CDC1000 SPECIFICATION</b>	<b>REV</b>	<b>PAGE</b>	<b>DATE</b>
		C	8 OF 51	2018. 11. 8

◆ *Power Connection*

Front View (male)

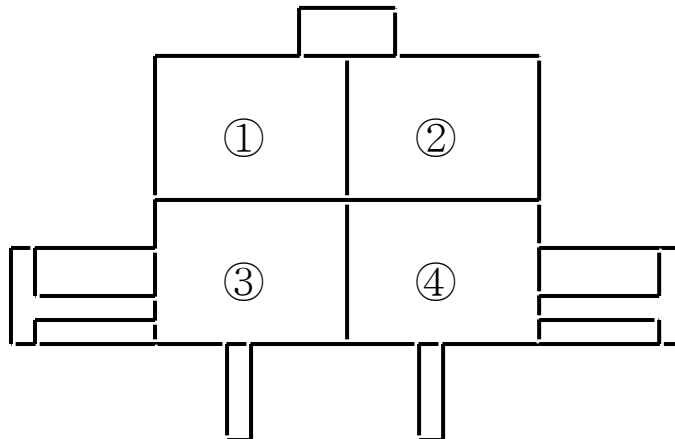

Part Number : 5566-04A1 (MOLEX)

<CDC-1000>

Pin No	Signal Name	Direction
1		INPUT
2	DC +24V	
3		
4	GND	

**CAUTION**

**RISK OF EXPLOSION IF BATTERY IS REPLACED  
BY AN INCORRECT TYPE.  
DISPOSE OF USED BATTERIES ACCORDING  
TO THE INSTRUCTIONS**



<b>Doc No</b>	<b>CDC1000 SPECIFICATION</b>	<b>REV</b>	<b>PAGE</b>	<b>DATE</b>
		C	9 OF 51	2018. 11. 8

## **SPECIFICATIONS**

### ◆ *basic functions*

	Spec	Remark
Dimension	Refer from page 20 to page 22	
Input power	DC 24V 3A	

### ◆ *Environment Requirements*

Operating Locus : in door use Only

Ambient Temperature

Storage : -20 °C to 70 °C(No functional error to be found in 12 hours after returning to normal environment)

Operating : 5 °C to 50°C (In 0°C to +5°C range, all specifications but 'Warped card' to be satisfied)

Ambient Relative Humidity

Storage : 0% to 95% RH(No functional error to be found in 12 hours after returning to normal environment)

Operating : 5 % 90% RH(No Condensation)

Vibration

: Amplitude 2mm, 10 to 50 Hz in X, Y, Z directions for 30min, 2G or less

Shock Endurance

: 30G, 11ms

Encoding Speed : 2.3 ~ 5 Sec/Card

Life Time : More than 500,000card passes(1pass : one forward and backward)

Error Rate : Less than 3/1,000 cycle(Test Card : KYT Standard)

<b>Doc No</b>	<b>CDC1000 SPECIFICATION</b>	<b>REV</b>	<b>PAGE</b>	<b>DATE</b>
		c	10 OF 51	2018. 11. 8

◆ *Controller Environment*

Communication

: RS422 OR RS232C Interface

: Baud Rate – 9600 BPS

19200 BPS

38400BPS (Default)

57600BPS

: 8Data bit, 1 Start bit, None Parity bit, 1 Stop Bit

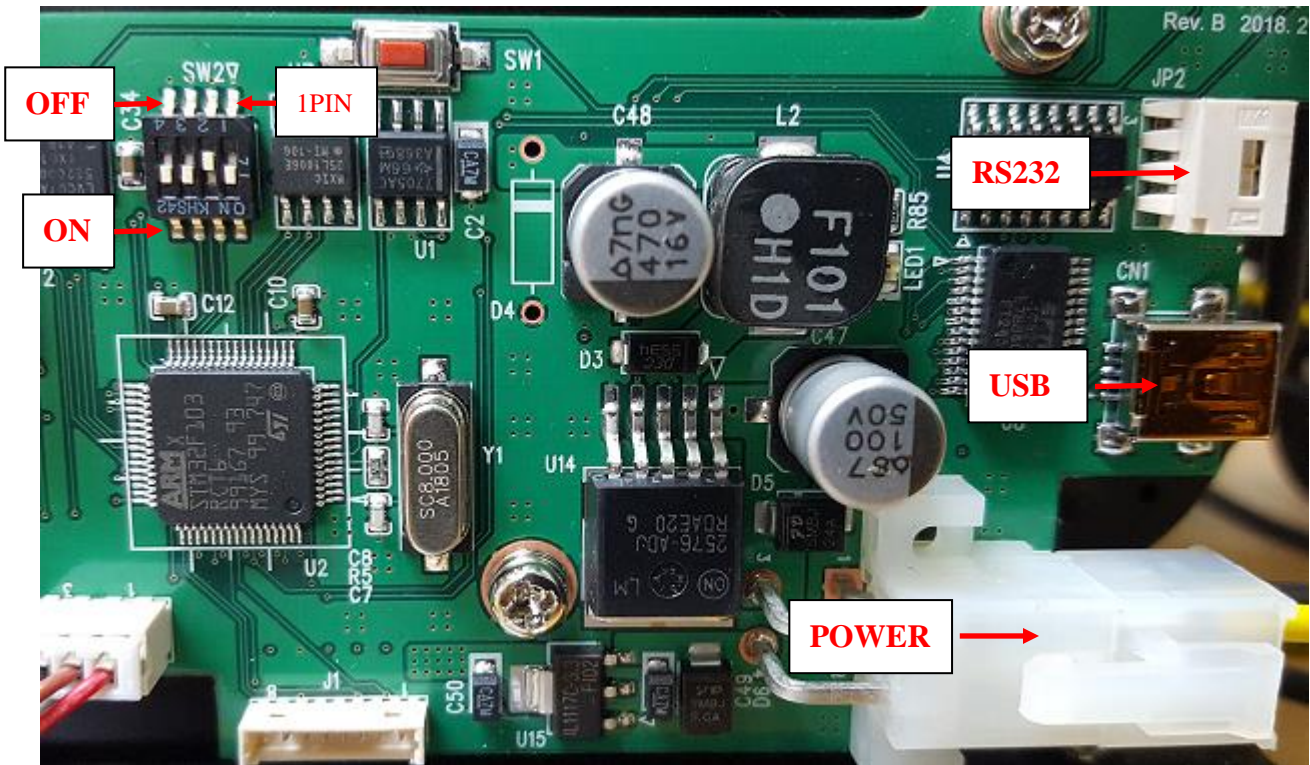

**-SW2 SETTING**

Baud Rate Setting

Pin No. 3	Pin No. 4	Baud Rate	Note
OFF	OFF	USB	USB-Serial port adapter internally.
ON	OFF	38400 BPS	Default
OFF	ON	19200 BPS	
ON	ON	9600 BPS	

<b>Doc No</b>	<b>CDC1000 SPECIFICATION</b>	<b>REV</b>	<b>PAGE</b>	<b>DATE</b>
		C	11 OF 51	2018. 11. 8

## **MAGNETIC CARD PROCESS**

◆ *Total processing time*

: Less than 1.2 Sec

◆ *Life and Reliability*

Life of Head : Minimum 1,000,000 passes

(One pass is for forward and backward movement)

Error Rate : 3/1000 cycle

◆ *Reference Standards*

: ISO 7811-1,2,3,4,5 : identification cards – Recording technique

◆ *Recording*

	ISO Track 1	ISO Track 2	ISO Track 3
BPI	210	75	210
Capacity	Max 79	Max 40	Max 107
Reading Methods	F2F		
Length	Variable		
Card thickness	Plastic : 0.76 ±0.08mm		

Doc No	CDC1000 SPECIFICATION	REV	PAGE	DATE
		C	12 OF 51	2018. 11. 8

## IC CARD PROCESS

This model provides most type of IC card compliant to ISO7816 T=0, T=1.

◆ *Processing time* : Less than 1 Sec

◆ *Number and Location of the contacts on IC Card*

: Number and location of the contacts on IC Card is specified in ISO 7816-2 figure 2  
Refer to Appendix A.

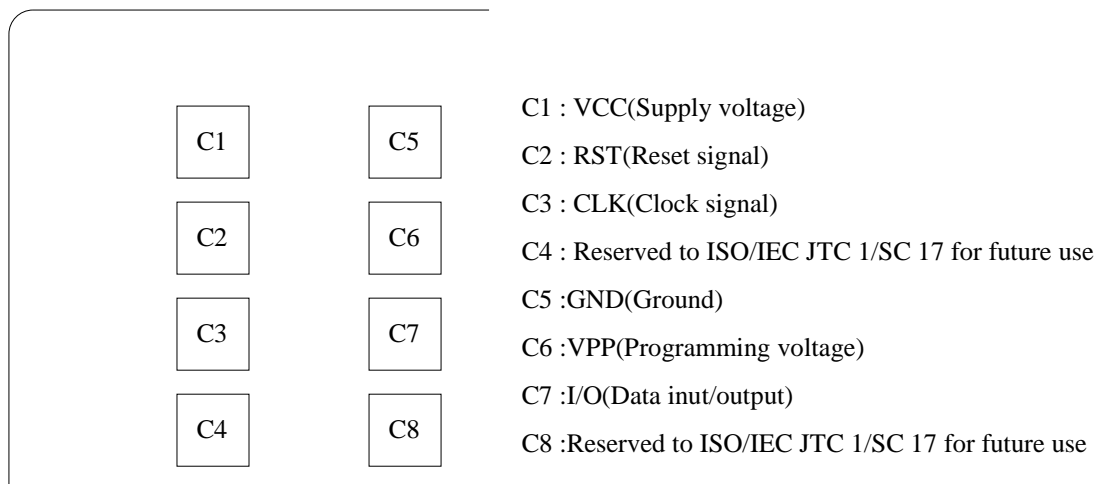

◆ *Power Consumption*

Motor Starting or Reversing : Less than 310mA(50mSec)

Card Feed & Reading : Less than 690mA

Card Feed & Writing : Less than 700mA

Steady state : Less than 180mA

◆ *Life and Reliability*

IC Contact : Approximately 1,000,000 passes

Error Rate : 3/1000 cycle

<b>Doc No</b>	<b>CDC1000 SPECIFICATION</b>	<b>REV</b>	<b>PAGE</b>	<b>DATE</b>
		C	13 OF 51	2018. 11. 8

## COMMUNICATION INTERFACE

### ◆ *Communication Method*

AsynCDConous, Half duplex.

Baud Rate : 9600 – 57600Bps , Default : 38400Bps

Start Bit : 1Bit

Data Length : 8Bit

Parity : None

Stop Bit : 1Bit

### ◆ *Communication Protocol Format*

#### *1 Command Frame Format.*

SOH	Null	Length	STX	CMD	DATA	ETX	BCC
1BYTE	1BYTE	2BYTE	1BYTE	3BYTE	N-BYTE	1BYTE	1BYTE

#### *2 Positive Response Frame Format*

SOH	Null	Length	STX	CMD	GOOD	0x01	DATA	ETX	BCC
1BYTE	1BYTE	2BYTE	1BYTE	3BYTE	1BYTE	1BYTE	N-BYTE	1BYTE	1BYTE

#### *3 Negative Response Frame Format*

SOH	Null	Length	STX	CMD	E-Code	0x00	ETX	BCC
1BYTE	1BYTE	2BYTE	1BYTE	3BYTE	2BYTE	1BYTE	1BYTE	1BYTE

#### *4 BCC (Check Sum)*

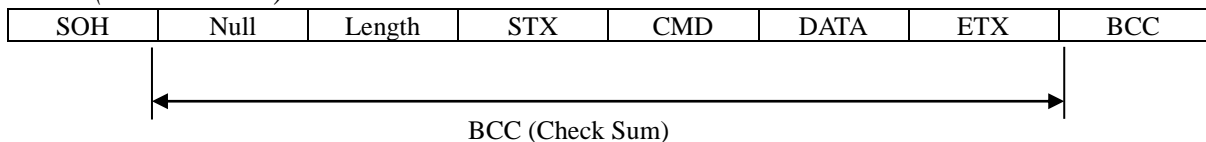

Command Frame BCC = Null ^ Length ^ STX ^ CMD ^ DATA ^ ETX.

Positive Response BCC = Null ^ Length ^ STX ^ CMD ^ GOOD ^ 0x01 ^ DATA ^ ETX.

Negative Response BCC = Null ^ Length ^ STX ^ CMD ^ E-Code ^ ETX.

N BYTE : Variable Length

<b>Doc No</b>	<b>CDC1000 SPECIFICATION</b>	<b>REV</b>	<b>PAGE</b>	<b>DATE</b>
		C	14 OF 51	2018. 11. 8

### 5. Explanatory note of technical words

Name	Detail
Null	Reserved. Always 0x00.
Length	Data Length from the CMD to DATA.
CMD	Instruction Code (3 Bytes)
GOOD	Normal Execution : 0x0000 (2 Bytes)
E-Code	Command Failed: Refer to "Error Code" (2 Bytes)
BCC	Check Sum.

<Length>, <E-Code>

High Byte	Low Byte
-----------	----------

### 6. Control Characters

Name	Hex Value	Detail
SOH	0x01	Start of Header
STX	0x02	Start of Text
ETX	0x03	End of Text
ENQ	0x05	Enquiry
ACK	0x06	Positive Acknowledge
NAK	0x15	Negative Acknowledge
CAN	0x18	Cancel

## 7 COMMUNICATION SEQUENCE / TIMING

### 7.1 CHARACTER GUIDE TIME

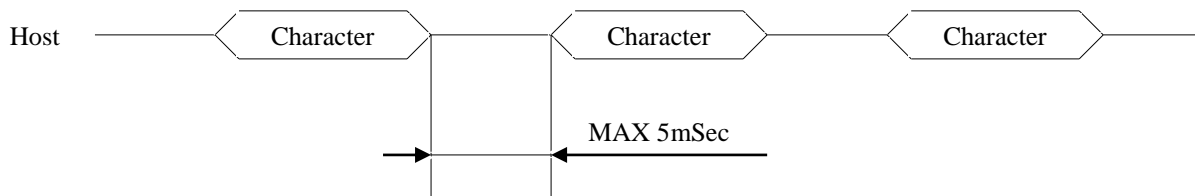

If no consecutive character within 5msec., do time out.

Doc No	CDC1000 SPECIFICATION	REV	PAGE	DATE
		C	15 OF 51	2018. 11. 8

### 7.2 Command

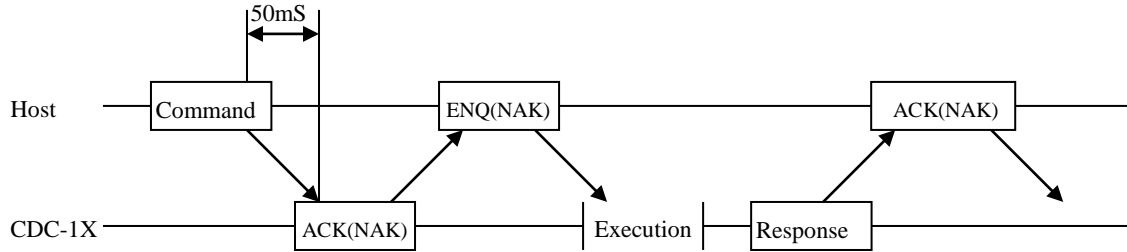

### 7.3 Inquiry

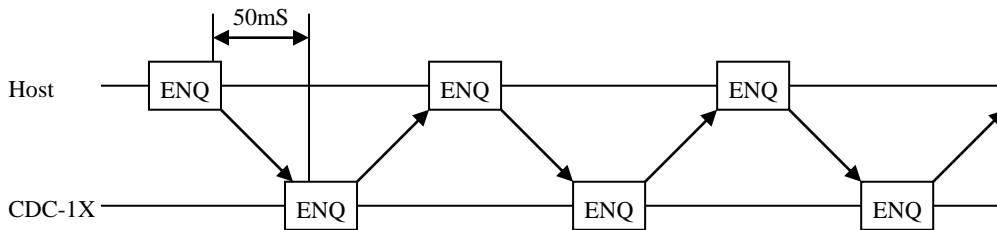

### 7.4 Sequence

#### 7.3.1 General

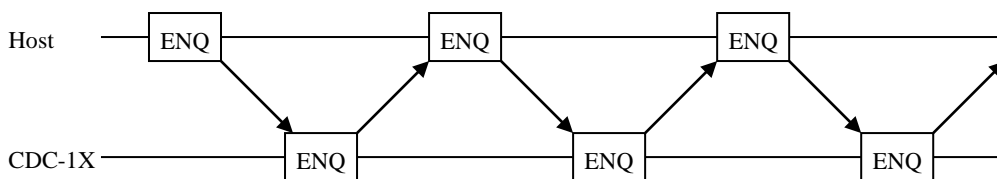
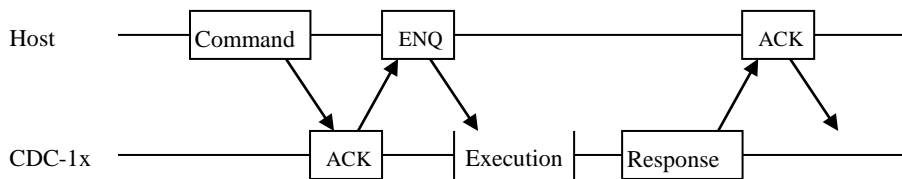

Doc No	CDC1000 SPECIFICATION	REV	PAGE	DATE
		C	16 OF 51	2018. 11. 8

7.3.2 Error1

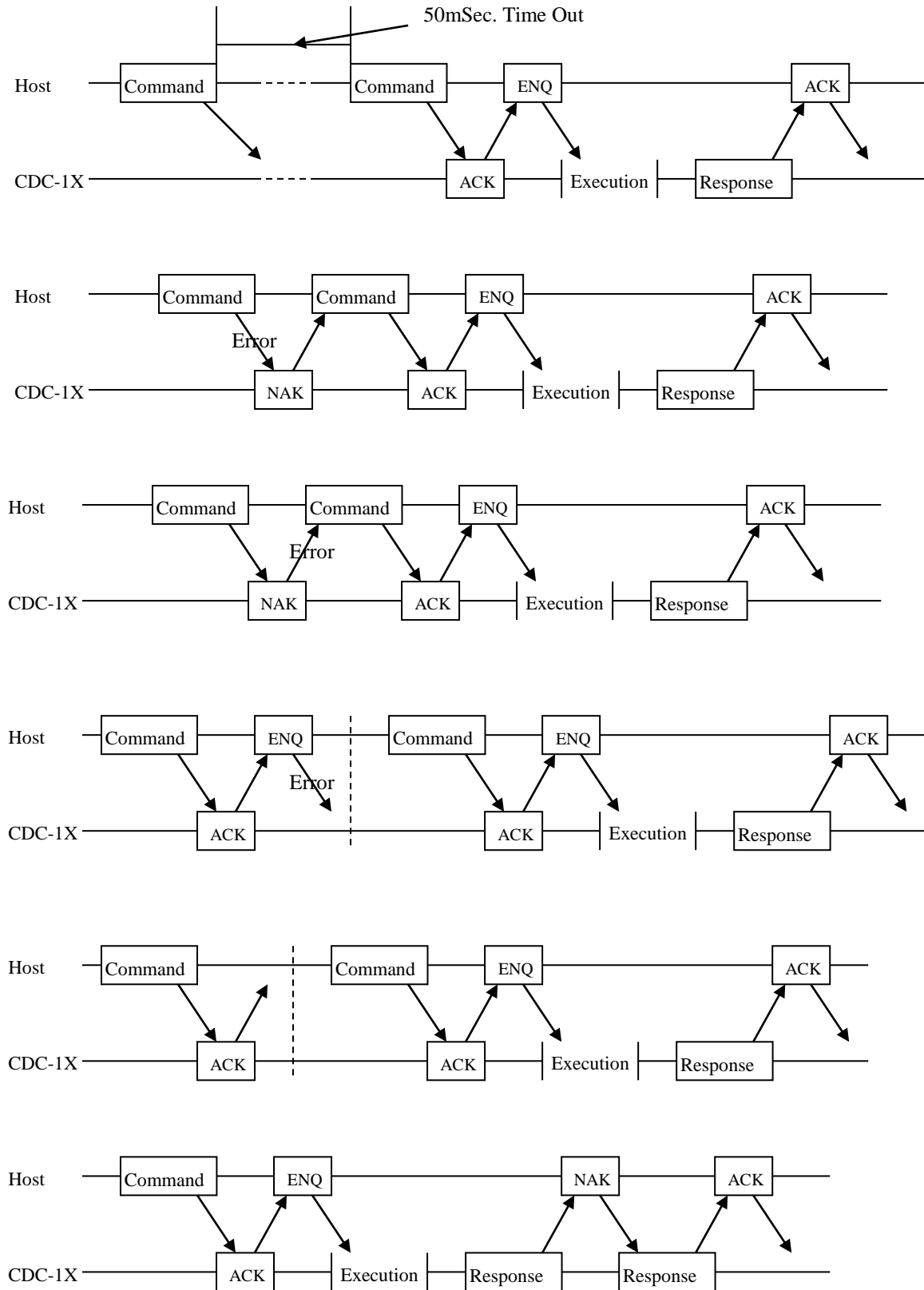



Doc No	CDC1000 SPECIFICATION	REV	PAGE	DATE
		C	17 OF 51	2018. 11. 8

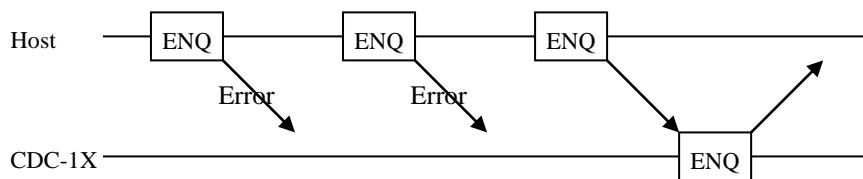
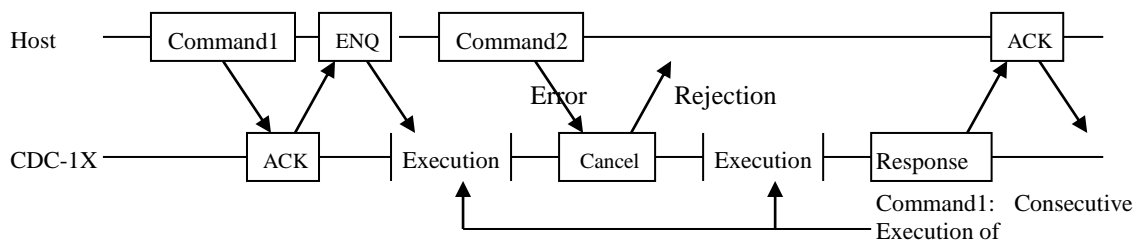
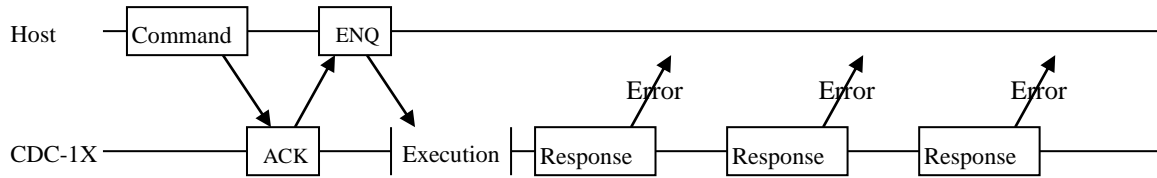
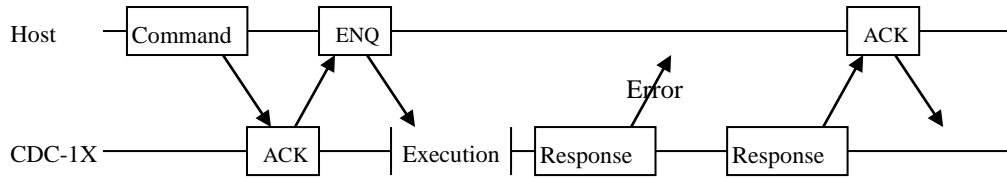
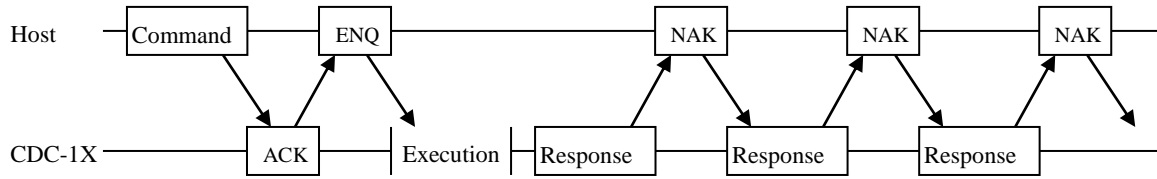
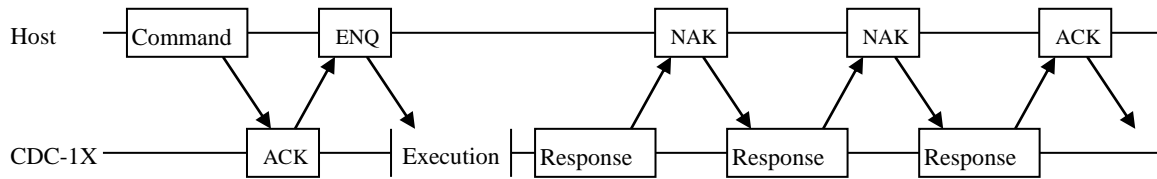

Doc No	CDC1000 SPECIFICATION	REV	PAGE	DATE
		C	18 OF 51	2018. 11. 8

### 7.3.3 Error2

- When received the NAK packet consecutively.

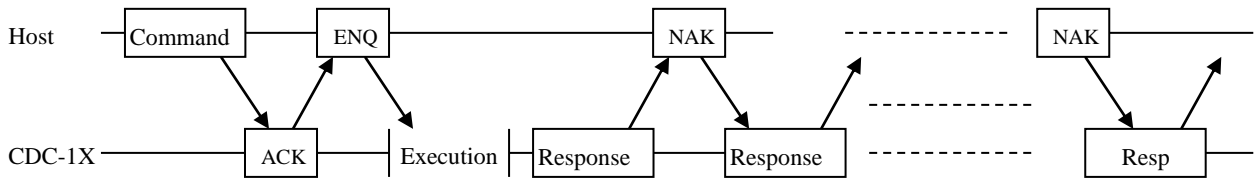

- When the Host sends the command without the ACK packet.

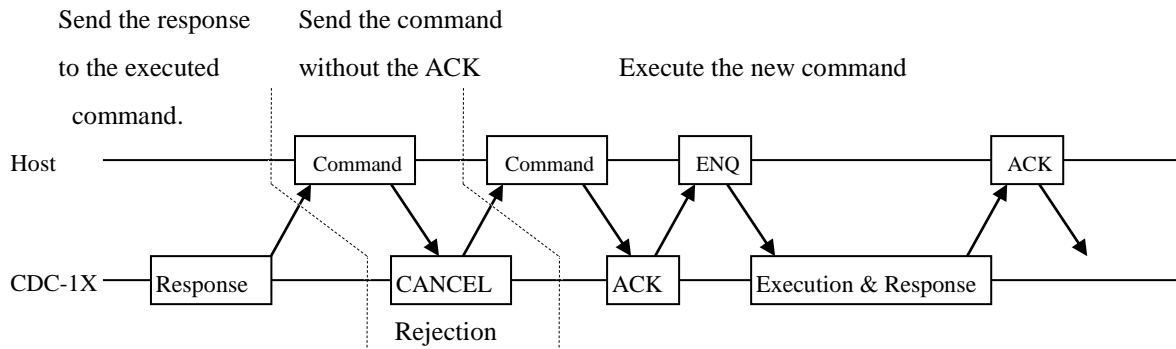

The terminal should ignore the command received before it sends the ACK packet, send the CANCEL packet. The second command will be treated as the ACK packet and executed with no ACK.

Doc No	CDC1000 SPECIFICATION	REV	PAGE	DATE
		C	19 OF 51	2018. 11. 8

## TECHNICAL DRAWING

< 100 Cards without MSRW >

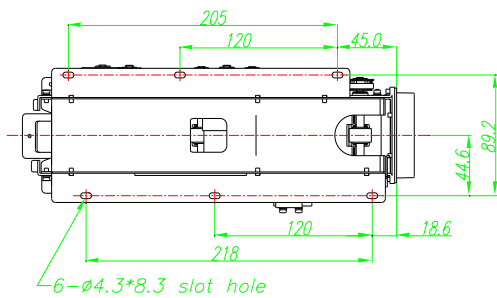
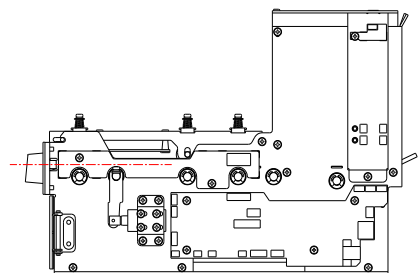
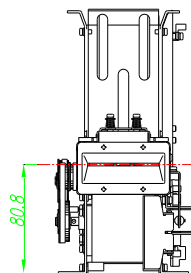
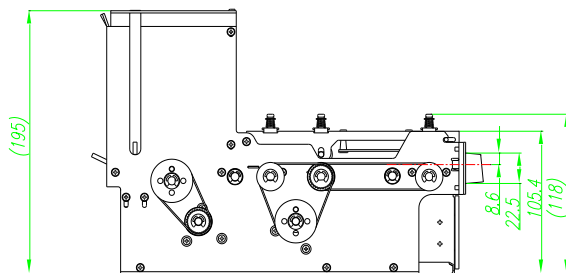
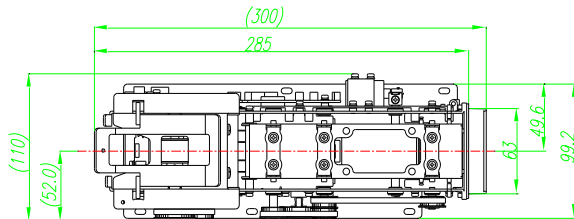

Doc No	CDC1000 SPECIFICATION	REV	PAGE	DATE
		C	20 OF 51	2018. 11. 8

< 300 Cards without MSRW >

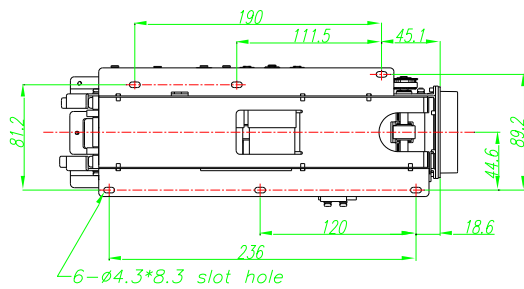
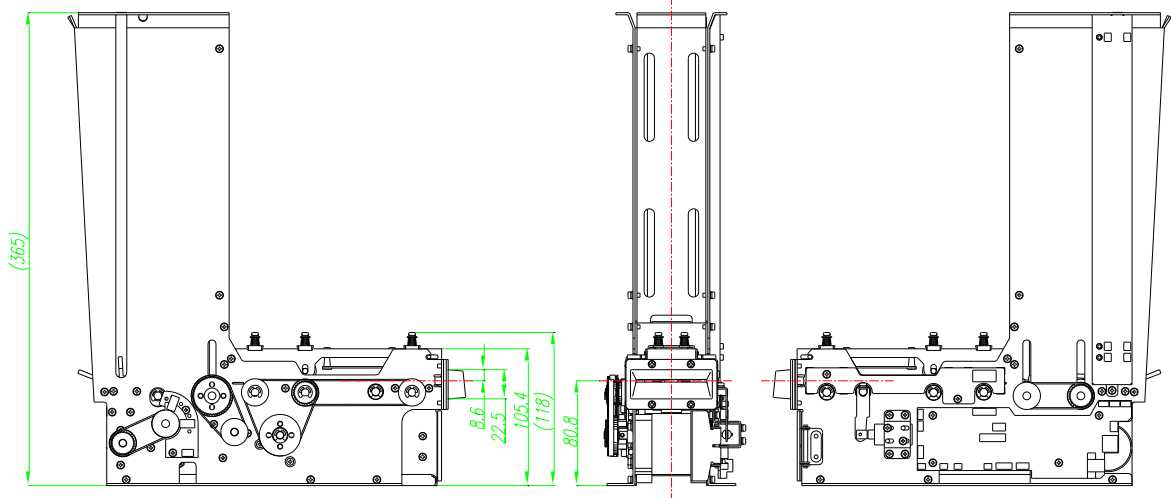
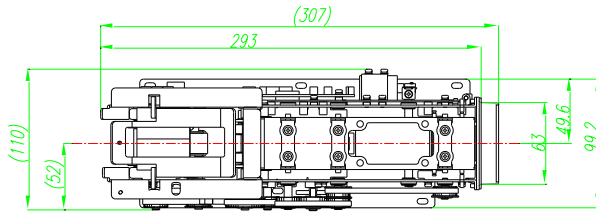

Doc No	CDC1000 SPECIFICATION	REV	PAGE	DATE
		C	21 OF 51	2018. 11. 8

<100 Cards with MSRW>

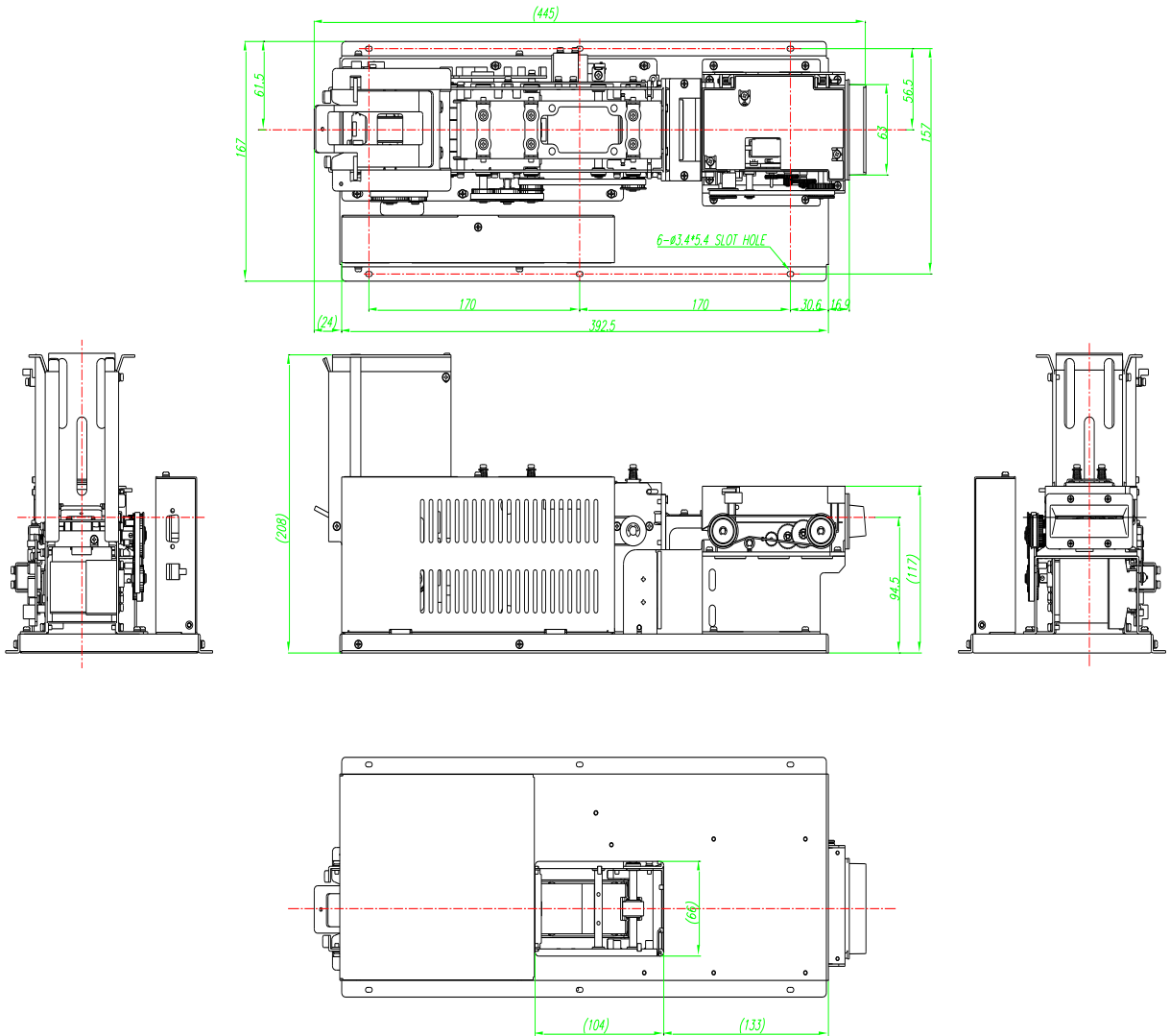

Doc No	CDC1000 SPECIFICATION	REV	PAGE	DATE
		C	22 OF 51	2018. 11. 8

<300 Cards with MSRW>

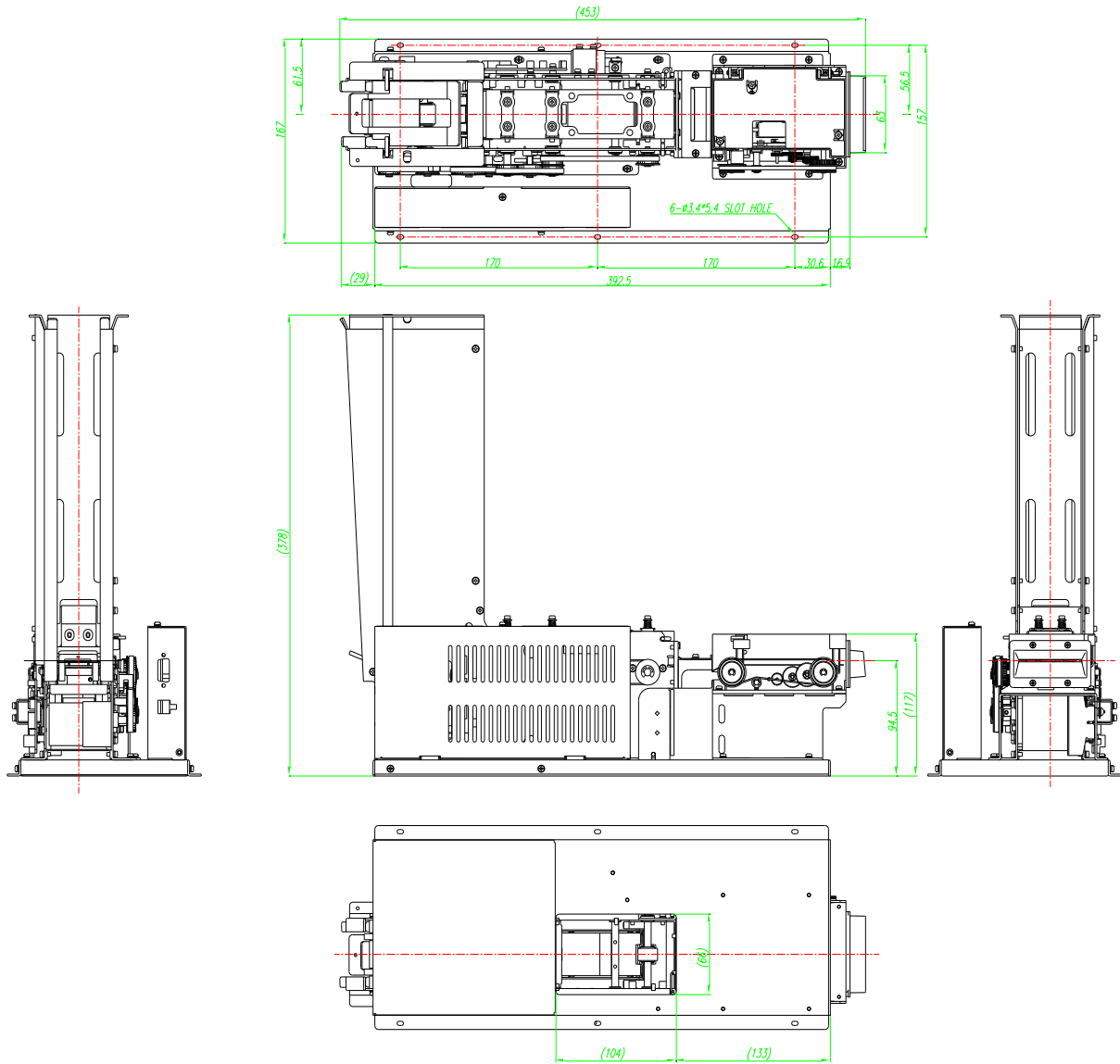



<b>Doc No</b>	<b>CDC1000 SPECIFICATION</b>	<b>REV</b>	<b>PAGE</b>	<b>DATE</b>
		C	24 OF 51	2018. 11. 8

◆ *Common*

*1 STATUS / SETTING*

1.1 “C11” : It is to check out Model number of CDC-1000.

☞ Command Format

SOH	Null	Length	STX	“C11”	ETX	Bcc
-----	------	--------	-----	-------	-----	-----

☞ Positive Response Format

SOH	Null	Length	STX	“C11”	GOOD	0x01	DATA	ETX	Bcc
-----	------	--------	-----	-------	------	------	------	-----	-----

☞ Negative Response Format

SOH	Null	Length	STX	“C11”	E-Code	0x00	ETX	Bcc
-----	------	--------	-----	-------	--------	------	-----	-----

☞ Response Data Structure

Model No
7Byte (ASCII)

1.2 “C12” : It is to check out Firmware Version of CDC-1000

☞ Command Format

SOH	Null	Length	STX	“C12”	ETX	Bcc
-----	------	--------	-----	-------	-----	-----

☞ Positive Response Format

SOH	Null	Length	STX	“C12”	GOOD	0x01	DATA	ETX	Bcc
-----	------	--------	-----	-------	------	------	------	-----	-----

☞ Negative Response Format

SOH	Null	Length	STX	“C12”	E-Code	0x00	ETX	Bcc
-----	------	--------	-----	-------	--------	------	-----	-----

☞ Response Data Structure

Firmware Version
5Byte (ASCII)



<b>Doc No</b>	<b>CDC1000 SPECIFICATION</b>	<b>REV</b>	<b>PAGE</b>	<b>DATE</b>
		C	25 OF 51	2018. 11. 8

1.3 “C13” : It is check out status of Stacker of CDC-1000

☞ Command Format

SOH	Null	Length	STX	“C13”	ETX	Bcc
-----	------	--------	-----	-------	-----	-----

☞ Positive Response Format

SOH	Null	Length	STX	“C13”	GOOD	0x01	DATA	ETX	Bcc
-----	------	--------	-----	-------	------	------	------	-----	-----

☞ Negative Response Format

SOH	Null	Length	STX	“C13”	E-Code	0x00	ETX	Bcc
-----	------	--------	-----	-------	--------	------	-----	-----

☞ Response Data Structure

Data1	Data2
1Byte (Hex)	1Byte (Hex)

☞ Data Variable

<Data1>

Code	Status	Note
0x00	Stacker Good	There are cards in the stacker
0x01	Stacker Empty	No card in the stacker
0x08	Stacker Full	It is not possible to collect cards as stacker is full.

☞ <Data2>

Code	Status	Note
0x01	Stacker Warning	A few cards in the Stacker.

<b>Doc No</b>	<b>CDC1000 SPECIFICATION</b>	<b>REV</b>	<b>PAGE</b>	<b>DATE</b>
		C	26 OF 51	2018. 11. 8

1.4 “C16” : The card is check by existent location.

☞ Command Format

SOH	Null	Length	STX	“C16”	ETX	Bcc
-----	------	--------	-----	-------	-----	-----

☞ Positive Response Format

SOH	Null	Length	STX	“C16”	GOOD	0x01	DATA	ETX	Bcc
-----	------	--------	-----	-------	------	------	------	-----	-----

☞ Negative Response Format

SOH	Null	Length	STX	“C16”	E-Code	0x00	ETX	Bcc
-----	------	--------	-----	-------	--------	------	-----	-----

☞ Response Data Structure

Card Position
1Byte (Hex)

☞ Data Variable

<Card Position>

Code	Sensor	Detail
0x01	SEN1	The card is locate NO.1
0x02	SEN2	The card is locate NO.2
0x04	SEN3	The card is locate NO.3
0x08	SEN4	The card is locate NO.4
0x10	SEN5	The card is locate NO.5
0x20	SEN6	The card is locate NO.6
0x40	SEN7	The card is locate NO.7
0x80	SEN8	The card is locate NO.8

<Without MSRW>

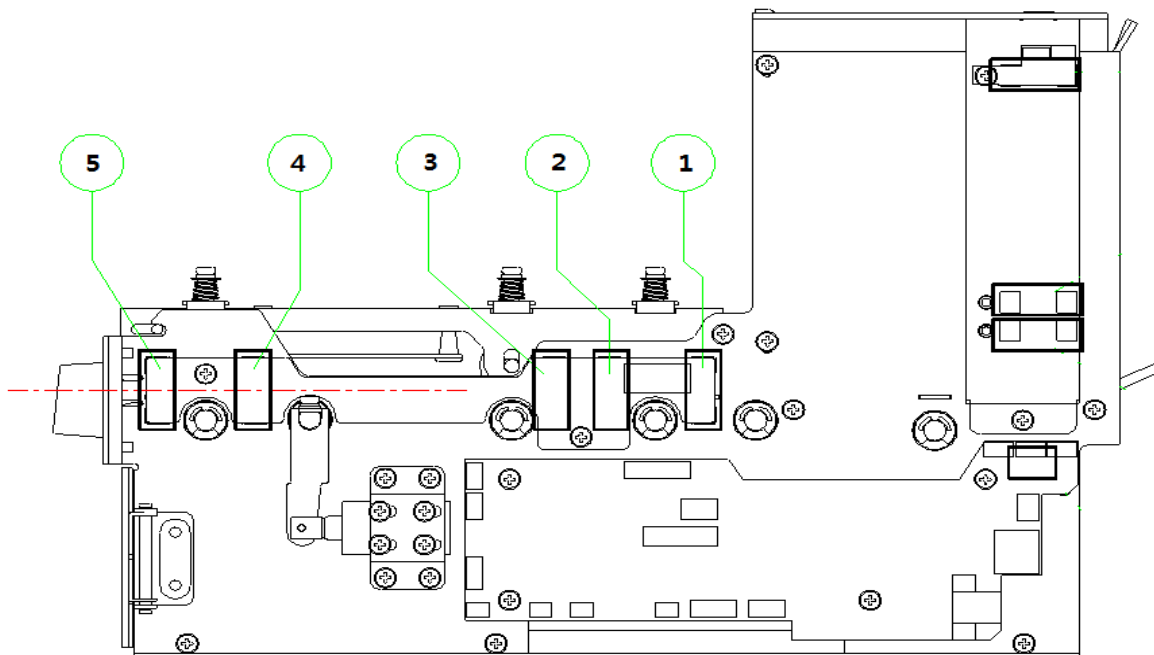

<b>Doc No</b>	<b>CDC1000 SPECIFICATION</b>	<b>REV</b>	<b>PAGE</b>	<b>DATE</b>
		C	27 OF 51	2018. 11. 8

<With MSRW>

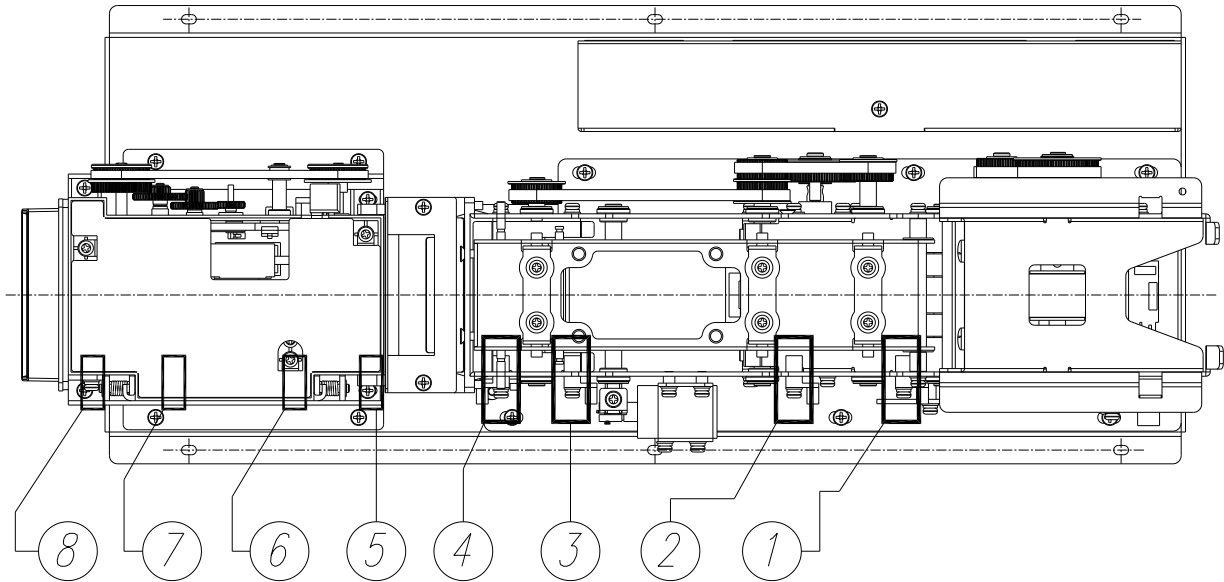

<b>Doc No</b>	<b>CDC1000 SPECIFICATION</b>	<b>REV</b>	<b>PAGE</b>	<b>DATE</b>
		C	28 OF 51	2018. 11. 8

## 2 SETTING

### 2.1 “C24” : It is to set or to check ‘Retry Count’.

#### ☞ Command Format

SOH	Null	Length	STX	“C24”	DATA	ETX	Bcc
-----	------	--------	-----	-------	------	-----	-----

#### ☞ Command Data Structure

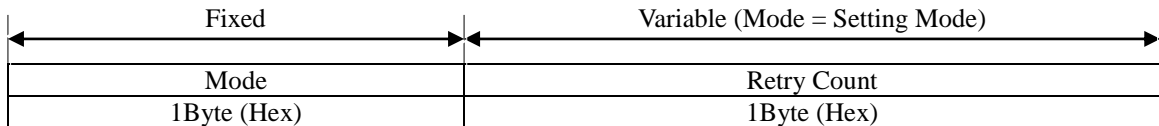

#### ☞ Positive Response Format

SOH	Null	Length	STX	“C24”	GOOD	0x01	DATA	ETX	Bcc
-----	------	--------	-----	-------	------	------	------	-----	-----

#### ☞ Negative Response Format

SOH	Null	Length	STX	“C24”	E-Code	0x00	ETX	Bcc
-----	------	--------	-----	-------	--------	------	-----	-----

#### ☞ Response Data Structure

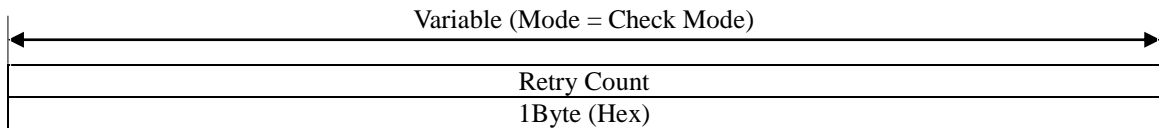

#### ☞ Data Variable

<Mode>

Code	Mode	Detail
0x01	‘Setting Mode’	Set ‘Retry Count’
0x02	‘Check Mode’	Check ‘Retry Count’

<Retry Count>

Code	Setting	Detail	Note
0x00	NON	Do not retry	
0x01	Once	Execute the instruction again.	
0x02	Twice	Retry it twice	
0x03	Three times	Retry it three times	Default

<b>Doc No</b>	<b>CDC1000 SPECIFICATION</b>	<b>REV</b>	<b>PAGE</b>	<b>DATE</b>
		C	29 OF 51	2018. 11. 8

2.2 “C26” : It is to change ‘Baud Rate’.

☞ Command Format

SOH	Null	Length	STX	“C26”	DATA	ETX	Bcc
-----	------	--------	-----	-------	------	-----	-----

☞ Command Data Structure

Baud Rate
1Byte (Hex)

☞ Positive Response Format

SOH	Null	Length	STX	“C26”	GOOD	0x01	ETX	Bcc
-----	------	--------	-----	-------	------	------	-----	-----

☞ Negative Response Format

SOH	Null	Length	STX	“C26”	E-Code	0x00	ETX	Bcc
-----	------	--------	-----	-------	--------	------	-----	-----

☞ Response Data Structure

☞ Data Variable

<Baud Rate>

Code	Setting	Detail	Note
0x01	9600Bps	Set Baud Rate to be 9600Bps	
0x02	19200Bps	Set Baud Rate to be 19200Bps	
0x03	38400Bps	Set Baud Rate to be 38400Bps	Default
0x04	57600Bps	Set Baud Rate to be 57600Bps	

<b>Doc No</b>	<b>CDC1000 SPECIFICATION</b>	<b>REV</b>	<b>PAGE</b>	<b>DATE</b>
		C	30 OF 51	2018. 11. 8

### 3 MOVE

3.1 “C31” : It is to take a card from Stacker and to move it to Card Reader / Writer Module.

☞ Command Format

SOH	Null	Length	STX	“C31”	DATA	ETX	Bcc
-----	------	--------	-----	-------	------	-----	-----

☞ Command Data Structure

0x00	Module
1Byte (Hex)	1Byte (Hex)

☞ Positive Response Format

SOH	Null	Length	STX	“C31”	GOOD	0x01	ETX	Bcc
-----	------	--------	-----	-------	------	------	-----	-----

☞ Negative Response Format

SOH	Null	Length	STX	“C31”	E-Code	0x00	ETX	Bcc
-----	------	--------	-----	-------	--------	------	-----	-----

☞ Data Variable

<Module>

Code	Setting	Detail
0x01	MSRW	Card transport to MSRW Module
0x02	IC	Card transport to IC Module
0x04	Feeder	Card transport to FEEDER Module

3.2 “C32” : It is take card to Card Reader / Writer Module

☞ Command Format

SOH	Null	Length	STX	“C32”	DATA	ETX	Bcc
-----	------	--------	-----	-------	------	-----	-----

☞ Command Data Structure

Module
1Byte (Hex)

☞ Positive Response Format

SOH	Null	Length	STX	“C32”	GOOD	0x01	DATA	ETX	Bcc
-----	------	--------	-----	-------	------	------	------	-----	-----

☞ Negative Response Format

SOH	Null	Length	STX	“C32”	E-Code	0x00	ETX	Bcc
-----	------	--------	-----	-------	--------	------	-----	-----

☞ Data Variable

<Module>

Code	Setting	Detail
0x01	MSRW	Card transport to MSRW Module
0x02	IC	Card transport to IC Module
0x04	Feeder	Card transport to FEEDER Module

<b>Doc No</b>	<b>CDC1000 SPECIFICATION</b>	<b>REV</b>	<b>PAGE</b>	<b>DATE</b>
		C	31 OF 51	2018. 11. 8

3.3 “C33” : It is to dispense out card to the front.

☞ Command Format

SOH	Null	Length	STX	“C33”	ETX	Bcc
-----	------	--------	-----	-------	-----	-----

☞ Positive Response Format

SOH	Null	Length	STX	“C33”	GOOD	0x01	ETX	Bcc
-----	------	--------	-----	-------	------	------	-----	-----

☞ Negative Response Format

SOH	Null	Length	STX	“C33”	E-Code	0x00	ETX	Bcc
-----	------	--------	-----	-------	--------	------	-----	-----

3.4 “C34” : It takes card to Bin Box (Capture)

☞ Command Format

SOH	Null	Length	STX	“C34”	ETX	Bcc
-----	------	--------	-----	-------	-----	-----

☞ Positive Response Format

SOH	Null	Length	STX	“C34”	GOOD	0x01	ETX	Bcc
-----	------	--------	-----	-------	------	------	-----	-----

☞ Negative Response Format

SOH	Null	Length	STX	“C34”	E-Code	0x00	ETX	Bcc
-----	------	--------	-----	-------	--------	------	-----	-----

3.5 “C39” : It is to take a card from Cartridge and to move it to Card Reader / Writer Module.

☞ Command Format

SOH	Null	Length	STX	“C39”	DATA	ETX	Bcc
-----	------	--------	-----	-------	------	-----	-----

☞ Command Data Structure

Cartridge 1Byte (Hex : 0x01)
---------------------------------

☞ Positive Response Format

SOH	Null	Length	STX	“C39”	GOOD	0x01	ETX	Bcc
-----	------	--------	-----	-------	------	------	-----	-----

☞ Negative Response Format

SOH	Null	Length	STX	“C39”	E-Code	0x00	ETX	Bcc
-----	------	--------	-----	-------	--------	------	-----	-----

<b>Doc No</b>	<b>CDC1000 SPECIFICATION</b>	<b>REV</b>	<b>PAGE</b>	<b>DATE</b>
		C	32 OF 51	2018. 11. 8

### ◆ *MAGNETIC CARD*

This section describes the commands that can use at the magnetic card.

The data to be written in every track should be conform to the ISO7816-2 standard, the available character is as follows. For more information about Magnetic card, refer to the ISO7816-2 standard.

Track	Available Character Set	Maximum characters	비고
Track #1	Character, Numbers	76	Except for the special character
Track #2	Numbers	37	
Track #3	Number	104	

The CDC-1000 provides two features for speedy processing. The first is to provide the command combined with 'FromStacker' and 'Magnetic Write' command. This feature enables to write on card in the dispenser stacker at a command.

The second is to lessen the processing time for the 'magnetic read' command repeated after latching the data read from card. To latch data occurs at a point of time when verify in the magnetic write command and execute the magnetic read command. However, the latched data is erased when the card is off from the terminal.



Doc No	CDC1000 SPECIFICATION	REV	PAGE	DATE
		C	33 OF 51	2018. 11. 8

Basic Magnetic Card Operations:

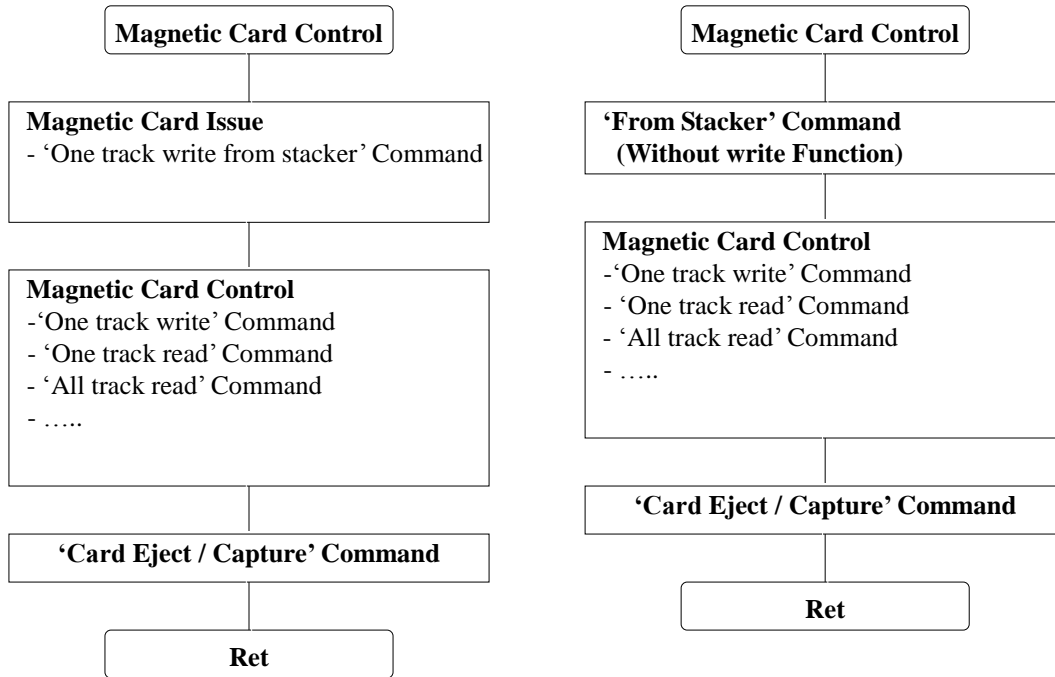

Magnetic Card Operations in the stacker

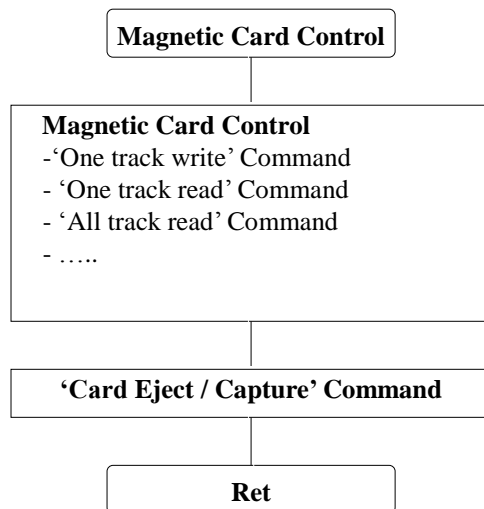

Magnetic Card Operations in the terminal

<b>Doc No</b>	<b>CDC1000 SPECIFICATION</b>	<b>REV</b>	<b>PAGE</b>	<b>DATE</b>
		C	34 OF 51	2018. 11. 8

## 1 MAGNETIC READ

1.1 “M31” : It is to read data on track chosen.

☞ Command Format

SOH	Null	Length	STX	“M31”	DATA	ETX	Bcc
-----	------	--------	-----	-------	------	-----	-----

☞ Command Data Structure

Track (1Byte)
---------------

☞ Positive Response Format

SOH	Null	Length	STX	“M31”	GOOD	0x01	DATA	ETX	Bcc
-----	------	--------	-----	-------	------	------	------	-----	-----

☞ Negative Response Format

SOH	Null	Length	STX	“M31”	E-Code	0x00	ETX	Bcc
-----	------	--------	-----	-------	--------	------	-----	-----

☞ Response Data Structure

Read Data (ASCII Code)
------------------------

☞ Data Variable

<Track>

Code	Setting	Detail
0x01	Track 1	Read data on Track 1
0x02	Track 2	Read data on Track 2
0x03	Track 3	Read data on Track 3

☞ Note

If the ‘Magnetic Read’ command is executed normally, the read data is latched.

1.4 “M35” : It is to read data from all three tracks.

☞ Command Format

SOH	Null	Length	STX	“M35”	ETX	Bcc
-----	------	--------	-----	-------	-----	-----

☞ Positive Response Format

SOH	Null	Length	STX	“M35”	GOOD	0x01	DATA	ETX	Bcc
-----	------	--------	-----	-------	------	------	------	-----	-----

☞ Negative Response Format

SOH	Null	Length	STX	“M35”	E-Code	0x00	ETX	Bcc
-----	------	--------	-----	-------	--------	------	-----	-----

☞ Response Data Structure

0x00	Track1 Data	0x00	Track2 Data	0x00	Track3 Data
1Byte(Hex)	(ASCII)	1Byte(Hex)	(ASCII)	1Byte(Hex)	(ASCII)

☞ Note

If the ‘Magnetic Read’ command is executed normally, the read data is latched.

Doc No	CDC1000 SPECIFICATION	REV	PAGE	DATE
		C	35 OF 51	2018. 11. 8

◆ *IC CARD*

This section describes the commands that can use at the IC card

The IC card should conform to the ISO7816-4 T=0/T=1, these cards is available.

Basic Operating Procedure for the IC card and Memory Card:

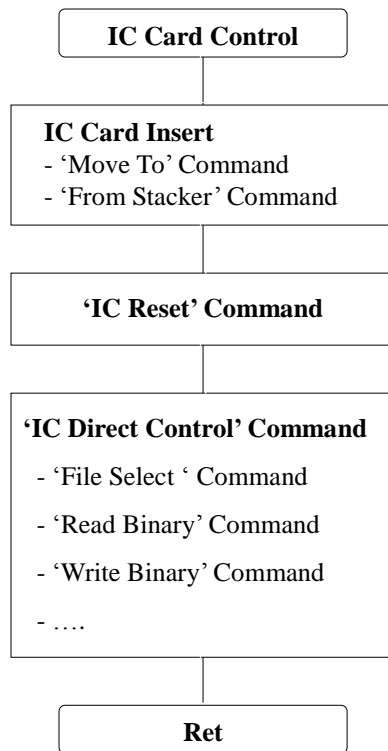

<b>Doc No</b>	<b>CDC1000 SPECIFICATION</b>	<b>REV</b>	<b>PAGE</b>	<b>DATE</b>
		C	36 OF 51	2018. 11. 8

## 1 IC CONTROL

### 1.1 “I21” : Reset the IC card and receive the ATR from card.

#### Command Format

SOH	Null	Length	STX	“I21”	ETX	Bcc
-----	------	--------	-----	-------	-----	-----

#### Positive Response Format

SOH	Null	Length	STX	“I21”	GOOD	0x01	DATA	ETX	Bcc
-----	------	--------	-----	-------	------	------	------	-----	-----

#### Negative Response Format

SOH	Null	Length	STX	“I21”	E-Code	0x00	ETX	Bcc
-----	------	--------	-----	-------	--------	------	-----	-----

#### Response Data Structure

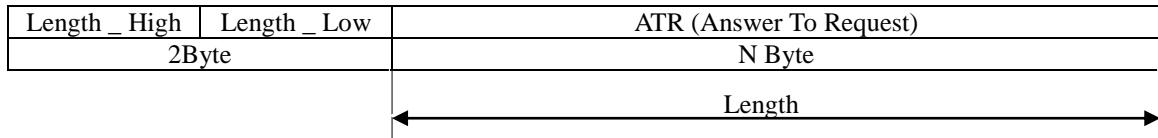

#### Example

##### SAMSUNG SCOS ATR

15 Byte	0x3B	0x6B	0x00	0x00	0x80	0x31	0x80	0x63
	0x53	0x46	0x01	0x83	0x03	0x90	0x00	

### 1.2 “I22” : Control the card conforming to the ISO 7816 T=0 / T=1, ISO 7816 – 4 standard directly.

#### Command Format

SOH	Null	Length	STX	“I22”	DATA	ETX	Bcc
-----	------	--------	-----	-------	------	-----	-----

#### Command Data Structure

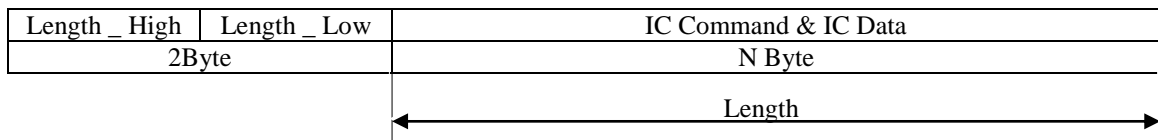

#### Positive Response Format

SOH	Null	Length	STX	“I22”	GOOD	0x01	DATA	ETX	Bcc
-----	------	--------	-----	-------	------	------	------	-----	-----

#### Negative Response Format

SOH	Null	Length	STX	“I22”	E-Code	0x00	ETX	Bcc
-----	------	--------	-----	-------	--------	------	-----	-----

#### Response Data Structure

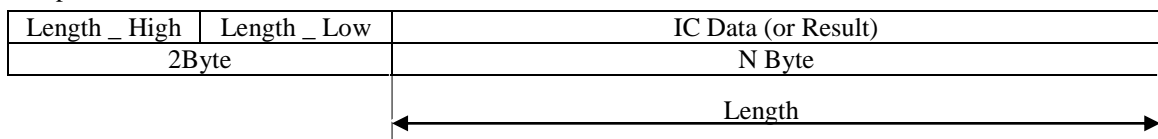

<b>Doc No</b>	<b>CDC1000 SPECIFICATION</b>	<b>REV</b>	<b>PAGE</b>	<b>DATE</b>
		C	37 OF 51	2018. 11. 8

IC Command & IC Data Structure

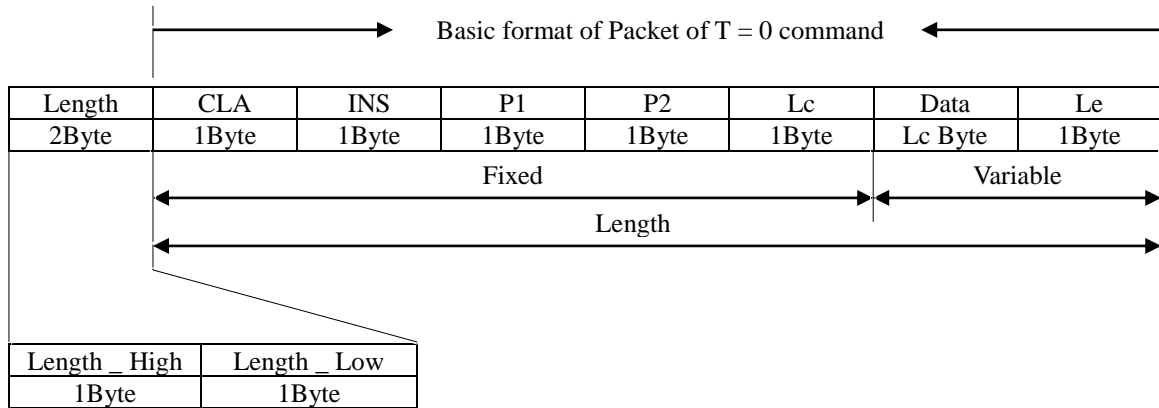

CLA	Class	Note
INS	Instruction	
P1	Offset(High Value)	
P2	Offset(Low Value)	
Lc	A number of data to transfer	Max Value : 255
Data	Data to Transfer	
Le	A number of data to receive	

Format of T = 0 Command

Command	INS Code (Hex Value)
Read Binary Command	B0
Write Binary Command	D0
Update Binary Command	D6
Erase Binary Command	0E
Read Record(s) Command	B2
Write Record Command	D2
Append Record Command	E2
Update Record Command	DC
Get Data Command	CA
Put Data Command	DA
Select File Command	A4
Verify Command	20
Internal Authenticate Command	88
External Authenticate Command	82
Get Challenge Command	84
Manage Channel Command	70

For more information, refer to the ISO 7816 – 4 standard.

<b>Doc No</b>	<b>CDC1000 SPECIFICATION</b>	<b>REV</b>	<b>PAGE</b>	<b>DATE</b>
		C	38 OF 51	2018. 11. 8

☞ Frame Command for SAMSUNG SCOS 3.0

Command	INS Code (Hex Value)
Put Key	EA
Create File	E0
Block	1E
UnBlock	18
Create Session	8A
Set Life Cycle	E8
Forbidden AC	1C
Initialize IEP	50
Load / Cancel IEP	52
Purchase /Unload / Complete IEP	54
Update Parameter	56
Read Balance	5C

<b>Doc No</b>	<b>CDC1000 SPECIFICATION</b>	<b>REV</b>	<b>PAGE</b>	<b>DATE</b>
		C	39 OF 51	2018. 11. 8

### ◆ *RF CARD*

This section describes the commands that can use at the 'RF CARD'.

The RF Module of his model supports only the MIFARE card.

Item	Cm0	Cm1	Cm2	Detail	Note
RF CARD READ / WRITE	'R'	'3'	'1'	RF Card Read in Block Range	
	'R'	'3'	'2'	RF Card Write in Block Range	Verify
	'R'	'3'	'6'	RF Card Read in Sector Range	
	'R'	'3'	'7'	RF Card Write in Sector Range	
BALANCE	'R'	'4'	'1'	Balance Increment	
	'R'	'4'	'2'	Balance Decrement	
	'R'	'5'	'3'	Select 'Secret Key Index'	
	'R'	'5'	'4'	Change 'RF Card Secret Key' to other Key	
	'R'	'5'	'5'	Key Set and Change 'Secret Key' to other Key	
	'R'	'5'	'6'	Key Set and Change 'Secret Key' to all the same Key value	
RF DETECT	'R'	'6'	'1'	Check RF card in antenna area	

To use the RF card, you need to initialize at first.

- Setting and updating of the secret key and secret key index.

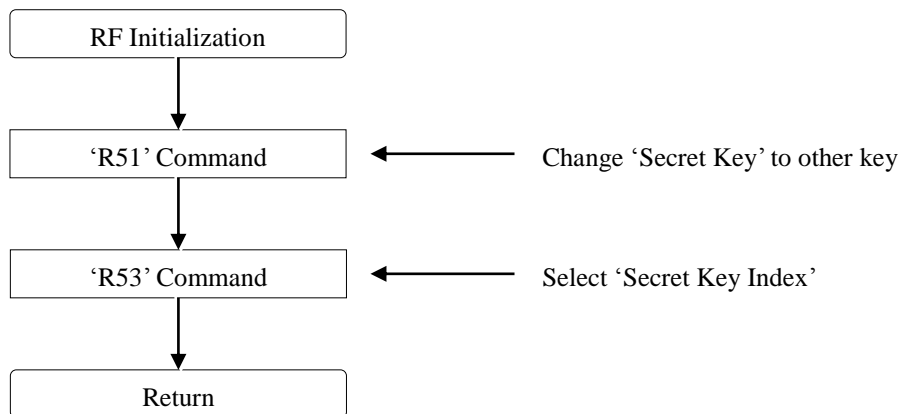

RF Module Initialization

<b>Doc No</b>	<b>CDC1000 SPECIFICATION</b>	<b>REV</b>	<b>PAGE</b>	<b>DATE</b>
		C	40 OF 51	2018. 11. 8

Basic Operating Procedure of the RF card:

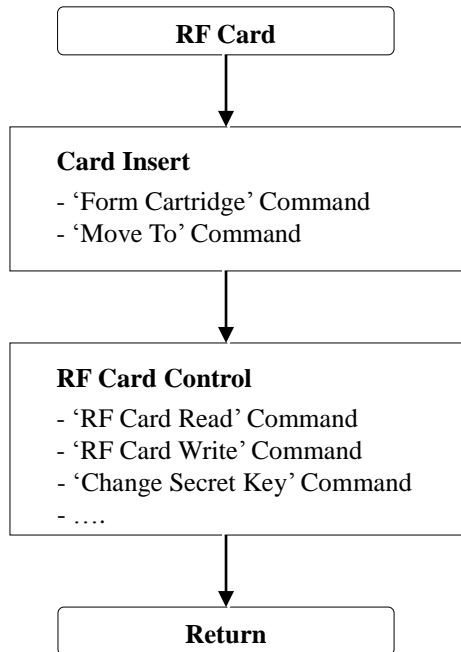

RF Card Basic Operating Procedures

Memory Architecture(map) of the RF card: 1Kbyte

Sector	Block	Size	Detail	Note
Sector 0	Block 0	16Byte	RF Card Information	Can't use
	Block 1	16Byte		
	Block 2	16Byte		
	Block 3	16Byte	'Sector Key'	
Sector 1	Block 0	16Byte	User Available Memory	
	Block 1	16Byte		
	Block 2	16Byte		
	Block 3	16Byte	'Sector Key'	
Sector 2	Block 0	16Byte	User Available Memory	
	Block 1	16Byte		
	Block 2	16Byte		
	Block 3	16Byte	'Sector Key'	
---	---	---	---	---
Sector 15	Block 0	16Byte	User Available Memory	
	Block 1	16Byte		
	Block 2	16Byte		
	Block 3	16Byte	'Sector Key'	



<b>Doc No</b>	<b>CDC1000 SPECIFICATION</b>	<b>REV</b>	<b>PAGE</b>	<b>DATE</b>
		C	41 OF 51	2018. 11. 8

### 3 RF CARD READ / WRITE

#### 3.1 "R31" : Read RF card data & Secret Key in block range

☞ Command Format

SOH	Null	Length	STX	"R31"	DATA	ETX	Bcc
-----	------	--------	-----	-------	------	-----	-----

☞ Command Data Structure

Sector	Block
0x00 – 0x0f	0x00 – 0x03
1Byte (Hex)	1Byte (Hex)

☞ Positive Response Format

SOH	Null	Length	STX	"R31"	GOOD	'1'	DATA	ETX	Bcc
-----	------	--------	-----	-------	------	-----	------	-----	-----

☞ Negative Response Format

SOH	Null	Length	STX	"R31"	E-Code	'0'	ETX	Bcc
-----	------	--------	-----	-------	--------	-----	-----	-----

☞ Response Data Structure

Sector	Block	Read Data
1Byte (Hex)	1Byte (Hex)	16 Byte (Hex)

D0	D1	D2	---	D14	D15
1Byte	1Byte	1Byte	---	1Byte	1Byte

#### 3.2 "R32" : Write RF card data in block range

☞ Command Format

SOH	Null	Length	STX	"R32"	DATA	ETX	Bcc
-----	------	--------	-----	-------	------	-----	-----

☞ Command Data Structure

Sector	Block	Write Data
0x00 – 0x0f	0x00 – 0x02	0x00 – 0xff
1Byte (Hex)	1Byte (Hex)	16Byte (Hex)

D0	D1	D2	---	D14	D15
1Byte	1Byte	1Byte	---	1Byte	1Byte

☞ Positive Response Format

SOH	Null	Length	STX	"R32"	GOOD	'1'	ETX	Bcc
-----	------	--------	-----	-------	------	-----	-----	-----

☞ Negative Response Format

SOH	Null	Length	STX	"R32"	E-Code	'0'	ETX	Bcc
-----	------	--------	-----	-------	--------	-----	-----	-----

<b>Doc No</b>	<b>CDC1000 SPECIFICATION</b>	<b>REV</b>	<b>PAGE</b>	<b>DATE</b>
		C	42 OF 51	2018. 11. 8

### 3.3 “R36” : Read RF card data in sector range

#### ☞ Command Format

SOH	Null	Length	STX	“R36”	DATA	ETX	Bcc
-----	------	--------	-----	-------	------	-----	-----

#### ☞ Command Data Structure

Sector
0x00 – 0x0f
1Byte (Hex)

#### ☞ Positive Response Format

SOH	Null	Length	STX	“R36”	GOOD	‘1’	DATA	ETX	Bcc
-----	------	--------	-----	-------	------	-----	------	-----	-----

#### ☞ Negative Response Format

SOH	Null	Length	STX	“R36”	E-Code	‘0’	ETX	Bcc
-----	------	--------	-----	-------	--------	-----	-----	-----

#### ☞ Response Data Structure

0x00	Read Data (0)	0x01	Read Data (1)	0x02	Read Data (2)
1Byte (Hex)	16Byte (Hex)	1Byte (Hex)	16Byte (Hex)	1Byte (Hex)	16Byte (Hex)

D0	D1	D2	---	D14	D15
1Byte	1Byte	1Byte	---	1Byte	1Byte

### 3.4 “R37” : Write RF card data in sector range (except Sector 0)

#### ☞ Command Format

SOH	Null	Length	STX	“R37”	DATA	ETX	Bcc
-----	------	--------	-----	-------	------	-----	-----

#### ☞ Command Data Structure

Sector	Write Data
0x01 – 0x0f	0x00 – 0xff
1Byte (Hex)	51Byte (Hex)

0x00	Read Data (0)	0x01	Read Data (1)	0x02	Read Data (2)
1Byte (Hex)	16Byte (Hex)	1Byte (Hex)	16Byte (Hex)	1Byte (Hex)	16Byte (Hex)

D0	D1	D2	---	D14	D15
1Byte	1Byte	1Byte	---	1Byte	1Byte

#### ☞ Positive Response Format

SOH	Null	Length	STX	“R37”	GOOD	‘1’	ETX	Bcc
-----	------	--------	-----	-------	------	-----	-----	-----

#### ☞ Negative Response Format

SOH	Null	Length	STX	“R37”	E-Code	‘0’	ETX	Bcc
-----	------	--------	-----	-------	--------	-----	-----	-----

<b>Doc No</b>	<b>CDC1000 SPECIFICATION</b>	<b>REV</b>	<b>PAGE</b>	<b>DATE</b>
		C	43 OF 51	2018. 11. 8

### *-BALANCE*

3.5 “R41” : Increment the balance of card to the specified amount.

☞ Command Format

SOH	Null	Length	STX	“R41”	DATA	ETX	Bcc
-----	------	--------	-----	-------	------	-----	-----

☞ Command Data Structure

Sector	Block	Index Value
0x00 – 0x0f	0x00 – 0x02	0x00000000 – 0xffffffff
1Byte (Hex)	1Byte (Hex)	4Byte (Hex)

V0	V1	V2	V3
0x00-0xff	0x00-0xff	0x00-0xff	0x00-0xff
1Byte(Hex, LSB)	1Byte(Hex)	1Byte(Hex)	1Byte(Hex, MSB)

☞ Positive Response Format

SOH	Null	Length	STX	“R41”	GOOD	‘1’	ETX	Bcc
-----	------	--------	-----	-------	------	-----	-----	-----

☞ Negative Response Format

SOH	Null	Length	STX	“R41”	E-Code	‘0’	ETX	Bcc
-----	------	--------	-----	-------	--------	-----	-----	-----

☞ Note

The balance should be written in the Electronic Purse format in the card.

3.6 “R42” : Decrement the balance of card to the specified amount..

☞ Command Format

SOH	Null	Length	STX	“R42”	DATA	ETX	Bcc
-----	------	--------	-----	-------	------	-----	-----

☞ Command Data Structure

Sector	Block	Index Value
0x00 – 0x0f	0x00 – 0x02	0x00000000 – 0xffffffff
1Byte (Hex)	1Byte (Hex)	4Byte (Hex)

V0	V1	V2	V3
0x00-0xff	0x00-0xff	0x00-0xff	0x00-0xff
1Byte(Hex, LSB)	1Byte(Hex)	1Byte(Hex)	1Byte(Hex, MSB)

☞ Positive Response Format

SOH	Null	Length	STX	“R42”	GOOD	‘1’	ETX	Bcc
-----	------	--------	-----	-------	------	-----	-----	-----

☞ Negative Response Format

SOH	Null	Length	STX	“R42”	E-Code	‘0’	ETX	Bcc
-----	------	--------	-----	-------	--------	-----	-----	-----

☞ Note

The balance should be written in the Electronic Purse format in the card.

<b>Doc No</b>	<b>CDC1000 SPECIFICATION</b>	<b>REV</b>	<b>PAGE</b>	<b>DATE</b>
		C	44 OF 51	2018. 11. 8

- *SECRET KEY*

3.7 “R53” : Select ‘Secret Key Index’

☞ Command Format

SOH	Null	Length	STX	“R53”	DATA	ETX	Bcc
-----	------	--------	-----	-------	------	-----	-----

☞ Command Data Structure

Index
0x01 – 0x02
1Byte (Hex)

☞ Positive Response Format

SOH	Null	Length	STX	“R53”	GOOD	‘1’	ETX	Bcc
-----	------	--------	-----	-------	------	-----	-----	-----

☞ Negative Response Format

SOH	Null	Length	STX	“R53”	E-Code	‘0’	ETX	Bcc
-----	------	--------	-----	-------	--------	-----	-----	-----

☞ Data Variable

<Index>

Code	Setting	Detail
0x01	KEY A	Select ‘Secret Key A’
0x02	KEY B	Select ‘Secret Key B’

☞ Note

KYT-5000 Series ‘Secret Key Index’ Default

‘Secret Key Index ‘ : KEY A

3.8 “R54” : Change RF card ‘Secret Key’ to other key

☞ Command Format

SOH	Null	Length	STX	“R54”	DATA	ETX	Bcc
-----	------	--------	-----	-------	------	-----	-----

☞ Command Data Structure

Sector	KEY A	Access	KEY B
0x00 – 0x0f	0x00 – 0xff	0x00 – 0xff	0x00 – 0xff
1Byte (Hex)	6Byte (Hex)	4Byte (Hex)	6Byte (Hex)

☞ Positive Response Format

SOH	Null	Length	STX	“R54”	GOOD	‘1’	ETX	Bcc
-----	------	--------	-----	-------	------	-----	-----	-----

☞ Negative Response Format

SOH	Null	Length	STX	“R54”	E-Code	‘0’	ETX	Bcc
-----	------	--------	-----	-------	--------	-----	-----	-----

☞ Warning

If you use this command incorrectly, it couldn’t be authenticated from the card.

<b>Doc No</b>	<b>CDC1000 SPECIFICATION</b>	<b>REV</b>	<b>PAGE</b>	<b>DATE</b>
		C	45 OF 51	2018. 11. 8

### 3.9 “R55” : Change ‘Secret Key’ to a new key from Key Set Number.

#### ☞ Command Format

SOH	Null	Length	STX	“R55”	DATA	ETX	Bcc
-----	------	--------	-----	-------	------	-----	-----

#### ☞ Command Data Structure

Key Set	Sector	KEY A	KEY B
0x00	0x00 – 0x0f	0x00 – 0xff	0x00 – 0xff
1 Byte(Hex)	1Byte (Hex)	6Byte (Hex)	6Byte (Hex)

#### ☞ Positive Response Format

SOH	Null	Length	STX	“R55”	GOOD	‘1’	ETX	Bcc
-----	------	--------	-----	-------	------	-----	-----	-----

#### ☞ Negative Response Format

SOH	Null	Length	STX	“R55”	E-Code	‘0’	ETX	Bcc
-----	------	--------	-----	-------	--------	-----	-----	-----

#### ☞ Note

Key Set <Index>

Code	Detail
0x00	Key Set 0

### 3.10 “R56” : Change ‘Secret Key’ to all the same key value from Key Set Number.

#### ☞ Command Format

SOH	Null	Length	STX	“R56”	DATA	ETX	Bcc
-----	------	--------	-----	-------	------	-----	-----

#### ☞ Command Data Structure

Key Set	KEY A	KEY B
0x00	0x00 – 0xff	0x00 – 0xff
1 Byte(Hex)	6Byte (Hex)	6Byte (Hex)

#### ☞ Positive Response Format

SOH	Null	Length	STX	“R56”	GOOD	‘1’	ETX	Bcc
-----	------	--------	-----	-------	------	-----	-----	-----

#### ☞ Negative Response Format

SOH	Null	Length	STX	“R56”	E-Code	‘0’	ETX	Bcc
-----	------	--------	-----	-------	--------	-----	-----	-----

#### ☞ Note

Key Set <Index>

Code	Detail
0x00	Key Set 0

<b>Doc No</b>	<b>CDC1000 SPECIFICATION</b>	<b>REV</b>	<b>PAGE</b>	<b>DATE</b>
		C	46 OF 51	2018. 11. 8

**- RF DETECT**

3.11 “R61” : RF card detect in antenna area

☞ Command Format

SOH	Null	Length	STX	“R61”	ETX	Bcc
-----	------	--------	-----	-------	-----	-----

☞ Positive Response Format

SOH	Null	Length	STX	“R61”	GOOD	DATA	‘1’	ETX	Bcc
-----	------	--------	-----	-------	------	------	-----	-----	-----

☞ Negative Response Format

SOH	Null	Length	STX	“R61”	E-Code	‘0’	ETX	Bcc
-----	------	--------	-----	-------	--------	-----	-----	-----

☞ Response Data Structure

Serial Number
Hex Code
4Byte

☞ Note

If the RF card is detected, this command send the serial number to host. But, it doesn't authenticate the Secret Key of the RF card.

Doc No	CDC1000 SPECIFICATION	REV	PAGE	DATE
		C	47 OF 51	2018. 11. 8

## ERROR DETAIL

### <GOOD>

Code : 0x0000

Description: Normal Execution

Procedures: None

### <NOT\_DEFINE\_COMMAND>

Code : 0x2001

Description : Using the command that does not defined in this model.

Action : Use the valid command in this model.

### <NOT\_USE\_COMMAND>

Code : 0x2002

Description : Not available command in this model.

Action : Use the valid command in this model.

### <COMM\_FRAME\_ERROR>

Code : 0x2003

Description : Sending the command that has the invalid communication frame.

Action : Check the data format and the corresponding module specification.

### <CARD\_JAM>

Code : 0x2004

Description : When the card is jammed.

Action : Remove the jammed card.

### <NO\_CARD>

Code : 0x2005

Description : No cards.

Action : Insert the card.

Doc No	CDC1000 SPECIFICATION	REV	PAGE	DATE
		C	48 OF 51	2018. 11. 8

<CARD\_PRESENT>

Code : 0x2006

Description : When the card exists already in the terminal.

Action : Eject the card.

<BUSY>

Code : 0x2007

Description : When the terminal is running or busy.

Action : Wait until the previous operation is completed.

<RTC\_ERROR>

Code : 0x2008

Description : When the RTC time is incorrect by internal terminal or incorrect input data.

Action : RTC time resetting

<TWO\_MORE>

Code : 0x2009

Description : When more than two cards exit in the terminal simultaneously.

Action : Remove the Card .

<CARD\_ERROR>

Code : 0x200B

Description : When the using card error, commonly occur in MSRW.

Action : Exchange the Card

<DISPENSER\_ERROR>

Code : 0x2100

Description : Not Applicable Dispenser.

Action : Reset the terminal and exchange the dispenser..

<DISPENSER\_COMM\_ERROR>

Code : 0x2101

Description : Dispenser communication error

Action : Check the communication line and reset the terminal.



Doc No	CDC1000 SPECIFICATION	REV	PAGE	DATE
		C	49 OF 51	2018. 11. 8

<ALL\_EMPTY>

Code : 0x2104

Description : No cards at stacker.

Action : Load the card in the stacker.

<MSRW\_ERROR>

Code : 0x2200

Description : The MS Reader/Writer that cannot use in this model.

Action : Change the MS Reader/Writer.

<MSRW\_COMM\_ERROR>

Code : 0x2201

Description : The MS Reader/Writer communication error.

Action : Check the communication line and reset the terminal.

<MSRW\_WRITE\_ERROR>

Code : 0x2202

Description : Error when the MS Reader/Writer is writing on the card.

Action : Clean the header and check the card.

<MSRW\_READ\_ERROR>

Code : 0x2203

Description : Error when the MS Reader/Writer is reading on the card.

Action : Clean the header and check the card.

<IC\_CONTACT\_ERROR>

Code : 0x2204

Description : Error while the terminal contacts the IC card.

Action : Be sure that the current card is an IC card.

<IC\_CONTROL\_ERROR>

Code : 0x2205

Description : Error while the terminal executes the IC card command.

Action : Check if the command is able to use in the contacted card.

Doc No	CDC1000 SPECIFICATION	REV	PAGE	DATE
		C	50 OF 51	2018. 11. 8

<MS BLANK ERROR >

Code : 0x2209

Description : No data on the magnetic card

Action : Write data on the magnetic card.

<RF\_ERROR>

Code : 0x2300

Description : Unavailable RF module.

Action : Change the RF MODULE

<RF\_COMM\_ERROR>

Code : 0x2301

Description : Communication error at the RF Module.

Action : Check the connection socket

<RF\_AUTHEN\_ERROR>

Code : 0x2302

Description : Authentication Error at the RF Module.

Action : Change the 'SECRET KEY'

<RF\_WRITE\_ERROR>

Code : 0x2303

Description : Error while the terminal writes at the RF Card.

Action : Be sure that the card exists in the detection range.

<RF\_READ\_ERROR>

Code : 0x2304

Description : Error while the terminal reads at the RF Card.

Action: Be sure that the card exists in the detection range.

<RF\_DETECT\_ERROR>

Error Code : 0x2305

Description : No RF Card.

Action : Insert the RF Card into the terminal.

<b>Doc No</b>	<b>CDC1000 SPECIFICATION</b>	<b>REV</b>	<b>PAGE</b>	<b>DATE</b>
			C	51 OF 51

<RF\_VALUE\_ERROR>

Code : 0x2306

Description : Error while the value increases(or decreases) at the RF Card.

Action: Be sure that the card exists in the detection range.