

Doc No	CCM-8XXX SERIES SPECIFICATION	REV	PAGE	DATE
9100-0070		A	1/54	2007. 07. 09.

Card Collecting Machine for Magnetic, Contact & Contactless IC Card (CCM-8XXXXXX Series)

Doc No	CCM-8XXX SERIES SPECIFICATION	REV	PAGE	DATE
9100-0070		A	2/54	2007. 07. 09.

REVISION HISTORY

No	DATE	DESCRIPTION	REV	PAGE	NOTE
1	2007.07.09	First edition	A	54	
2					
3					
4					
5					
6					
7					
8					
9					
9					
10					
11					
12					
13					

Doc No	CCM-8XXX SERIES SPECIFICATION	REV	PAGE	DATE
9100-0070		A	3/54	2007. 07. 09.

MODEL NAME INFORMATION

C C M- 8

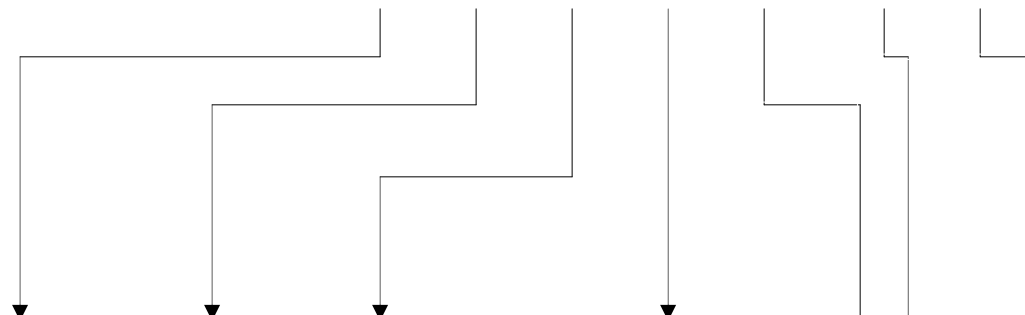

Interface	Function	MS / IC / RF	Track	Option
RS232C	8: Elevator Type Collecting Machine	0 : - 1 : MS Only 2 : MS & IC 3 : MS & RF 4 : MS & IC & RF 5 : IC Only 6 : RF Only 7 : IC & RF	0 : Without MS 1 : ISO 1 Trk 2 : ISO 2 Trk 3 : ISO 3 Trk 4 : ISO 1,2 Trk 5 : ISO 1,3 Trk 6 : ISO 2,3 Trk 7 : ISO 1,2,3 Trk	0: Without BEZEL 1: LOW-CO 2: HI-CO 3: LOW-CO & SHUTTER 4: HI-CO & SHUTTER 5: LOW-CO BEZEL 6: HIGH-CO BEZEL 7: SHUTTER 8: BEZEL * STANDARD BEZEL : SHORT BEZEL

Thickness		Option II	Option III
A: 0.2T B: 0.38T C: 0.5T D: 0.76T E: 0.84T F: 1.0T	G: 0.2T H: 0.38T I: 0.5T J: 0.76T K: 0.84T L: 1.0T	0:500PCS 1:1000PCS 2:1500PCS	RFU
 With capture box	 Without capture box		

Doc No	CCM-8XXX SERIES SPECIFICATION	REV	PAGE	DATE
9100-0070		A	4/54	2007. 07. 09.

C O N T E N T S

Overview -----	5
System Block Diagram -----	6
Specification -----	8
Magnetic Card Process -----	10
IC Card Process -----	11
RF Card Process -----	12
Communication Interface -----	13
Technical Drawing -----	19
Command Detail -----	22
Error Detail -----	49
Precautions -----	54

Doc No	CCM-8XXX SERIES SPECIFICATION	REV	PAGE	DATE
9100-0070		A	5/54	2007. 07. 09.

OVERVIEW

CCM-8XXX Series is a set of card collecting machine for the magnetic, IC, and RF card in conjunction with the CCM-8XXX and 3XXX series. This model can be used for magnetic card conforming to the ISO7816-2 standard and most of the IC cards conforming with the ISO7816-4 T=0,T=1. Additionally, this model also can be used for the RF card conforming to the MIFARE.

This model simplified the command for magnetic card, minimize the delay time occurs in the communication data processing, and improved the speed due to function to issue the all tracks at a time.

This model has the following advantages:

- 1) With bottom-up direction card hopper, the CCM-8XXX can be fitted to most type of existing Parking system and Highway fare collection system and various Entry control system.
- 2) With exchangeable cartridge, card cards can be loaded easily and quickly.
- 3) With big capacity of cartridge, long and un-intended automatic operation is allowed
- 4) Flexible card selection is allowed since the CCM-8XXX can provide all the magnetic, contact and contactless IC card collecting function is prepared.

As an automatic collecting machine, this model can be used in collecting most types of credit card and debit card in financial area.

Doc No	CCM-8XXX SERIES SPECIFICATION	REV	PAGE	DATE
9100-0070		A	6/54	2007. 07. 09.

SYSTEM BLOCK DIAGRAM

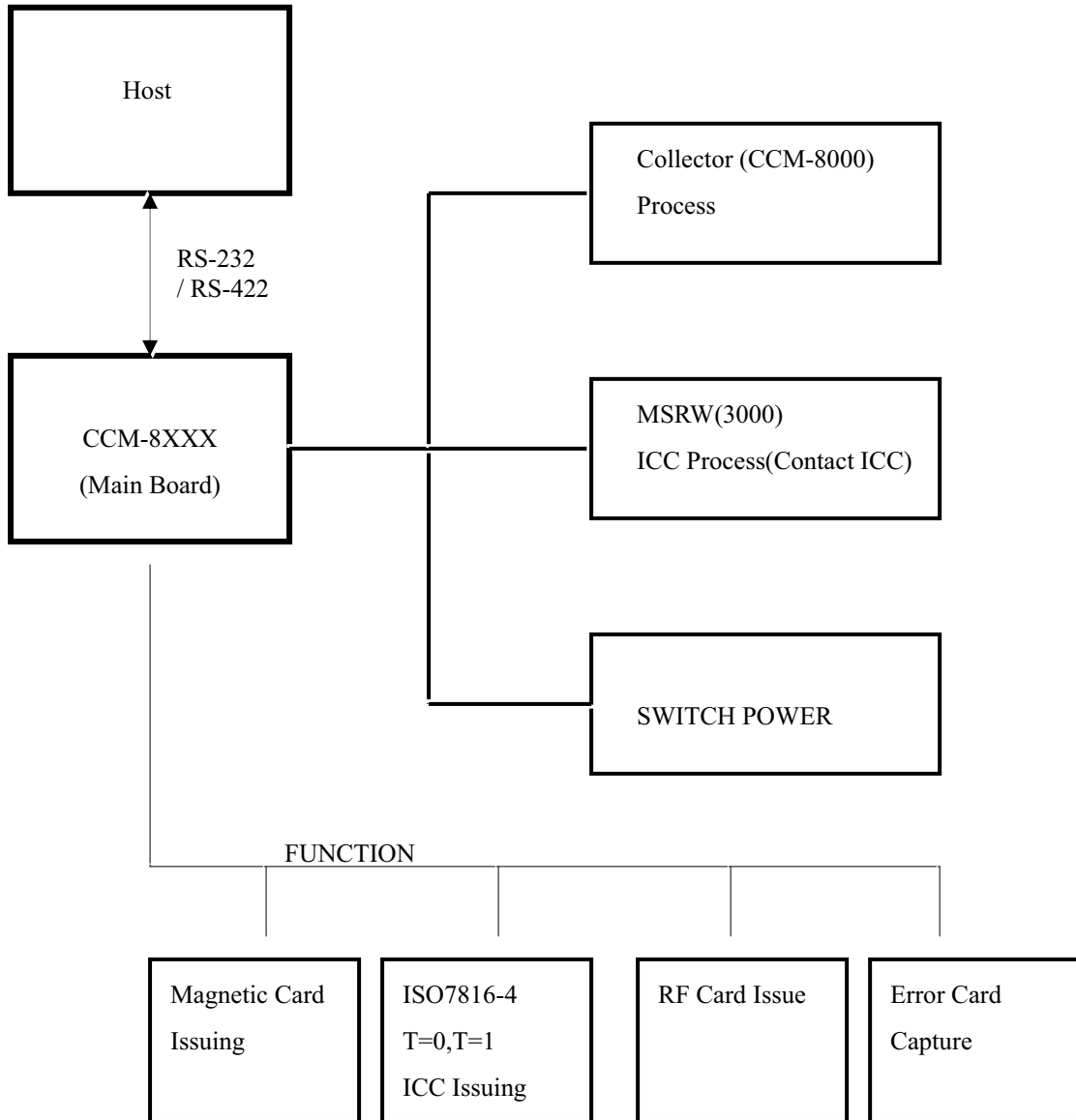

Doc No	CCM-8XXX SERIES SPECIFICATION	REV	PAGE	DATE
9100-0070		A	7/54	2007. 07. 09.

◆ *RS – 232 Connection*

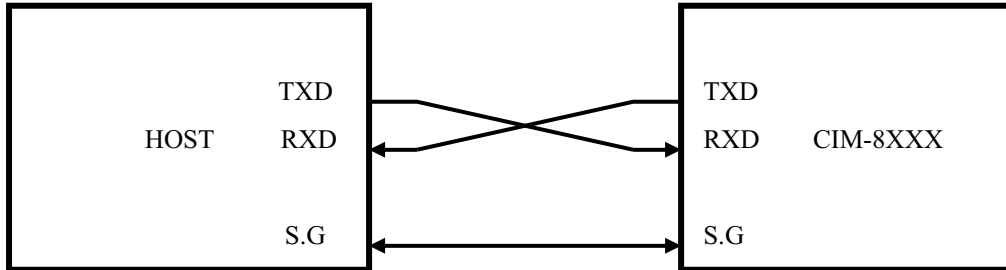

CASE 1) Part Number : RED-9S-LNA(HIROSE)

Pin No	INDEX	Remark
2	RXD	Receive
3	TXD	Transmit
5	S.G	Signal Ground

◆ *RS422 Connection*

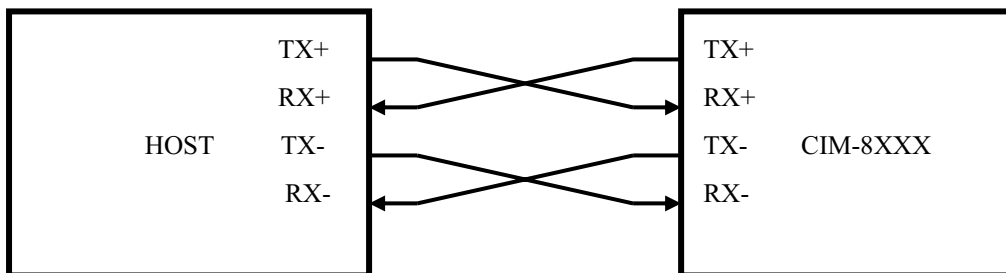

CASE 1) Part Number : RED-9S-LNA(HIROSE)

Pin No	INDEX	Remark
1	TX+	
4	RX+	
6	TX-	
8	RX-	

Doc No	CCM-8XXX SERIES SPECIFICATION	REV	PAGE	DATE
9100-0070		A	8/54	2007. 07. 09.

SPECIFICATIONS

◆ *basic functions*

	Spec	Remark
Dimension		Refer to page 20
Weight	500pcs: 15Kg 1000pcs: 19Kg 1500pcs: 23Kg	Refer to page 20
Input power	AC 110 ~ AC 220V Free voltage	
Card Feeding Speed	150 mm/Sec ±10%	

◆ *Environment Requirements*

Operating Locus : In door use Only

Ambient Temperature

Storage : -20 °C to 70 °C (No functional error to be found in 12 hours after returning to normal environment)

Operating : 5 °C to 50°C (In 0°C to +5°C range, all specifications but 'Warped card' to be satisfied)

Ambient Relative Humidity

Storage : 0% to 95% RH(No functional error to be found in 12 hours after returning to normal environment)

Operating : 5 % 90% RH(No Condensation)

Vibration

: Amplitude 2mm, 10 to 50 Hz in X, Y, Z directions for 30min, 2G or less

Shock Endurance

: 30G, 11ms

Doc No	CCM-8XXX SERIES SPECIFICATION	REV	PAGE	DATE
9100-0070		A	9/54	2007. 07. 09.

◆ *Controller Environment*

Communication

: RS422 OR RS232C Interface

: Baud Rate – 9600 BPS

– 19200 BPS

– 38400BPS(Default)

– 57600BPS

: 8Data bit, 1 Start bit, None Parity bit, 1 Stop Bit

Doc No	CCM-8XXX SERIES SPECIFICATION	REV	PAGE	DATE
9100-0070		A	10/54	2007. 07. 09.

MAGNETIC CARD PROCESS

3000 series is able to encode data on all three tracks of ISO 1,2 and 3 in one pass, which makes read / write process time shorter. It is a basic and standard option to read and write to Low – Co card.

◆ *Total processing time* : Less than 1.2 Sec

◆ *Life and Reliability.*

Life of Head : Approximately 500,000 passes.
(One pass is for forward and backward movement)

Error Rate : 5/1000 cycle.

◆ *Reference Standards.*

: ISO 7811-1,2,3,4,5 : identification cards – Recording technique

◆ *Recording.*

	ISO Track 1	ISO Track 2	ISO Track 3
BPI	210	75	210
Capacity	Max 79	Max 40	Max 107
Reading Methods	F2F		
Length	Variable		
Card thickness	Plastic : 0.76 ±0.08mm		

Doc No	CCM-8XXX SERIES SPECIFICATION	REV	PAGE	DATE
9100-0070		A	11/54	2007. 07. 09.

IC CARD PROCESS

This model provides most type of IC card compliant to ISO7816 T=0,T=1 .

◆ *Processing time* : Less than 1 Sec

◆ *Number and Location of the contacts on IC Card.*

: Number and location of the contacts on IC Card is specified in ISO 7816-2

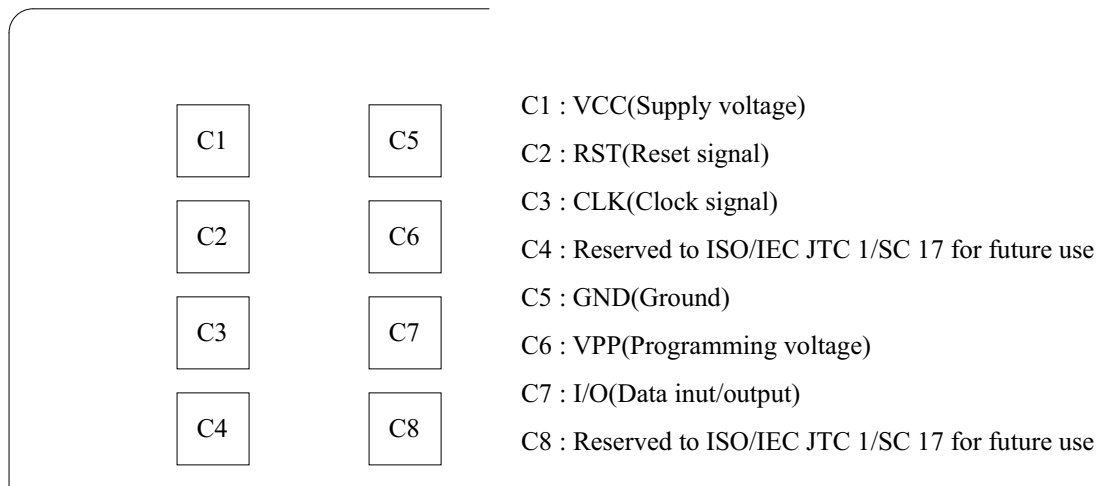

◆ *Life and Reliability.*

IC Contact : Approximately 1,000,000 passes

Error Rate : 5/1000 cycle

Doc No	CCM-8XXX SERIES SPECIFICATION	REV	PAGE	DATE
9100-0070		A	12/54	2007. 07. 09.

RF CARD PROCESS

The RF module supports most of RF cards conforming with the ISO14443-3 Type A (MIFARE Card) with 8Kbits memory.

◆ *Processing time* : Once Block.

Command	Parameter	Time (mSec)		Note
		Type	Max	
Card Read	1 Block	100		Without card moving
Card Write	1 Block	150		Without card moving, With Verify
Card Decrement	1 Block	120		Without card moving
Card Increment	1 Block	120		Without Card moving

◆ *Operating Frequency.*

Operating Frequency : 13.56 MHz

Data Transfer Baud : Baud rate 106Kbaud

Doc No	CCM-8XXX SERIES SPECIFICATION	REV	PAGE	DATE
9100-0070		A	13/54	2007. 07. 09.

COMMUNICATION INTERFACE

◆ *Communication Method.*

Asynchronous, Half duplex.

Baud Rate : 9600 – 57600Bps , Default : 38400Bps

Start Bit : 1Bit

Data Length : 8Bit

Parity : None

Stop Bit : 1Bit

◆ *Communication Protocol Format.*

1 *Command Frame Format.*

SOH	Null	Length	STX	CMD	DATA	ETX	BCC
1 byte	1 byte	2 byte	1 byte	3 byte	N byte	1 byte	1 byte

(N byte: Variable length)

2 *Positive Response Frame Format.*

SOH	Null	Length	STX	CMD	GOOD	0x01	DATA	ETX	BCC
1 byte	1 byte	2 byte	1 byte	3 byte	2 byte	1 byte	X byte	1 byte	1 byte

3 *Negative Response Frame Format.*

SOH	Null	Length	STX	CMD	E-Code	0x00	ETX	BCC
1 byte	1 byte	2 byte	1 byte	3 byte	2 byte	1 byte	1 byte	1 byte

4 *BCC (Check Sum).*

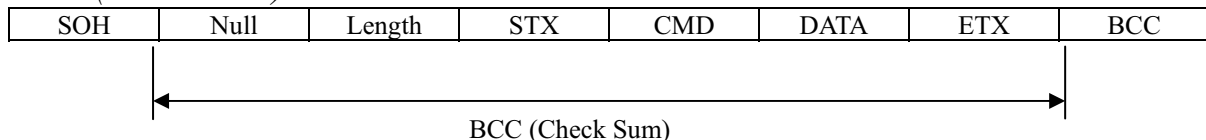

Command Frame BCC = Null ^ Length ^ STX ^ CMD ^ DATA ^ ETX.

Positive Response BCC = Null ^ Length ^ STX ^ CMD ^ GOOD ^ 0x01 ^ DATA ^ ETX.

Negative Response BCC = Null ^ Length ^ STX ^ CMD ^ E-Code ^ ETX.

Doc No	CCM-8XXX SERIES SPECIFICATION	REV	PAGE	DATE
9100-0070		A	14/54	2007. 07. 09.

5. *Explanatory note of technical words.*

Name	Detail
Null	Reserved. Always 0x00.
Length	Data Length from the CMD to DATA.
CMD	Instruction Code (3 Bytes)
GOOD	Normal Execution : 0x0000 (2 Bytes)
E-Code	Command Failed: Refer to "Error Code" (2 Bytes)
BCC	Check Sum.

<Length>, <E-Code>

High Byte	Low Byte
-----------	----------

6. *Control Characters.*

Name	Hex Value	Detail
SOH	0x01	Start of Header
STX	0x02	Start of Text
ETX	0x03	End of Text
ENQ	0x05	Enquiry
ACK	0x06	Positive Acknowledge
NAK	0x15	Negative Acknowledge
CAN	0x18	Cancel

7 *COMMUNICATION SEQUENCE / TIMING.*

7.1 Command.

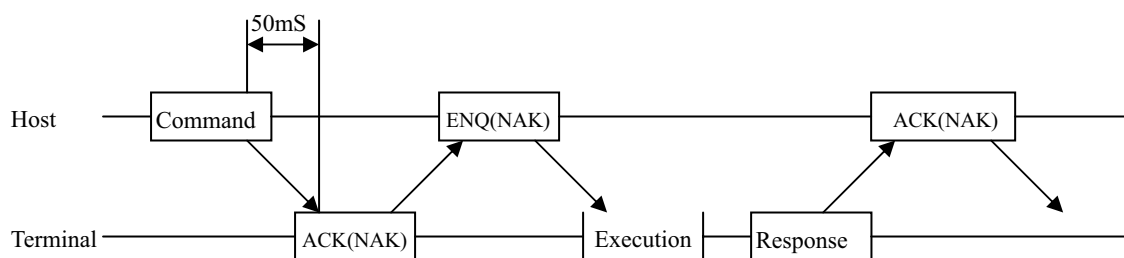

Doc No	CCM-8XXX SERIES SPECIFICATION	REV	PAGE	DATE
9100-0070		A	15/54	2007. 07. 09.

7.2 Inquiry.

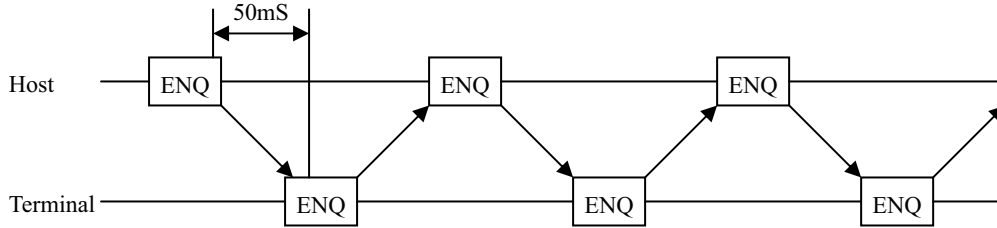

7.3 Sequence.

7.3.1 General.

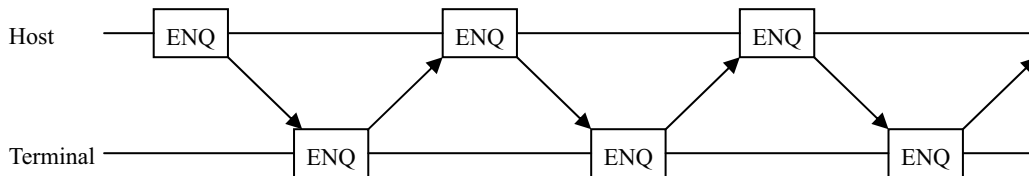
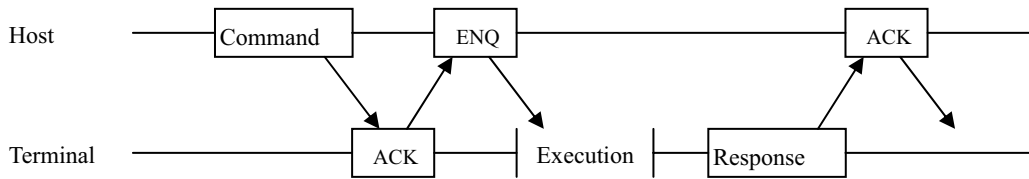

Doc No	CCM-8XXX SERIES SPECIFICATION	REV	PAGE	DATE
9100-0070		A	16/54	2007. 07. 09.

7.3.2 Event

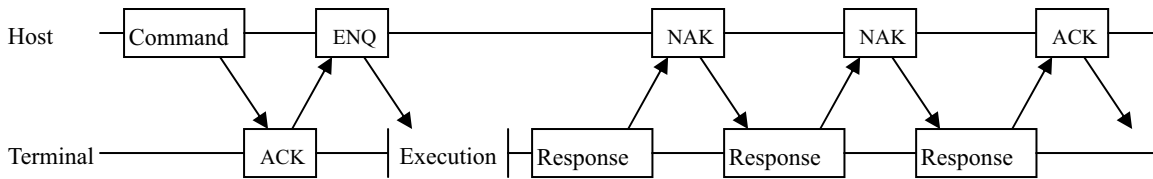
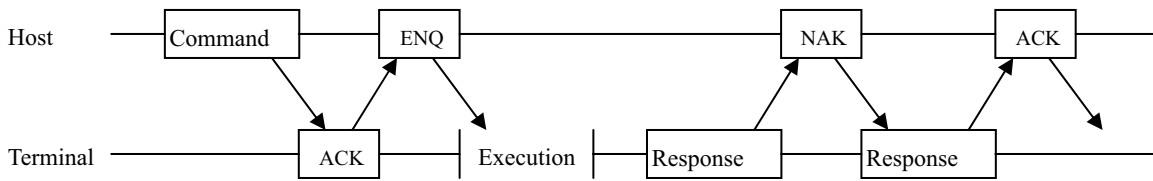
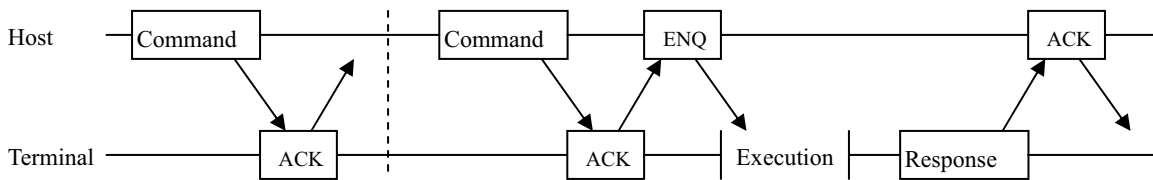
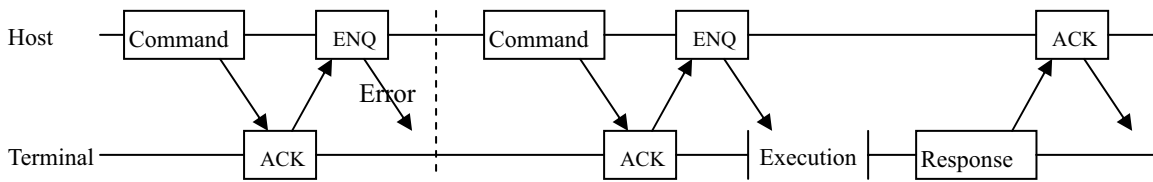
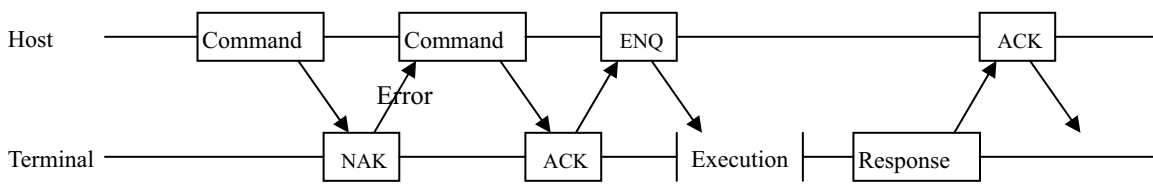
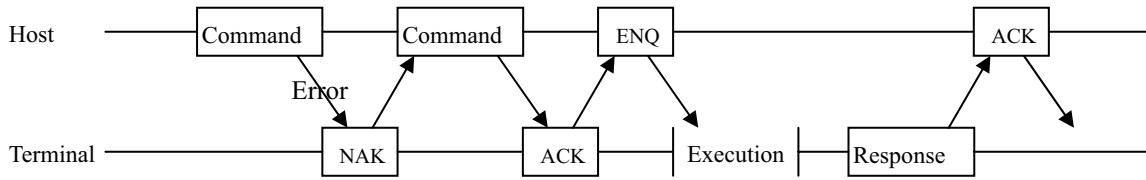

Doc No	CCM-8XXX SERIES SPECIFICATION	REV	PAGE	DATE
9100-0070		A	17/54	2007. 07. 09.

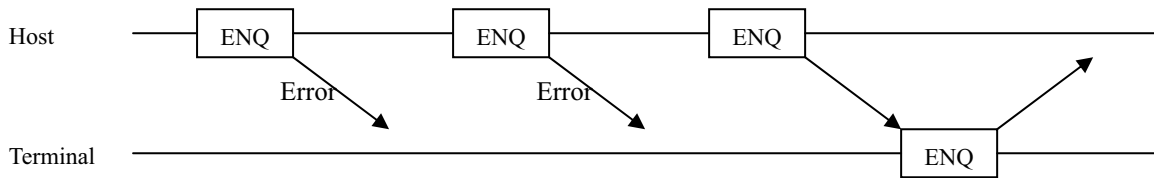
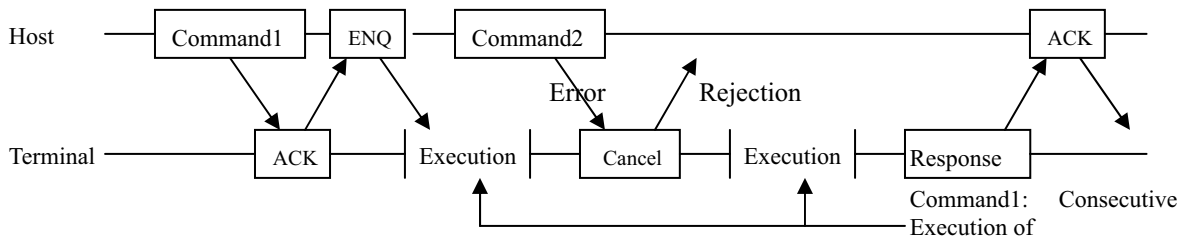
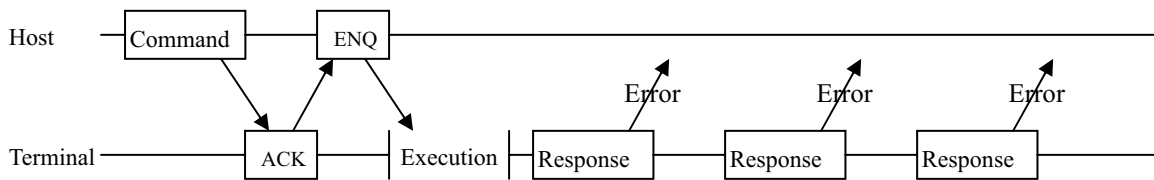
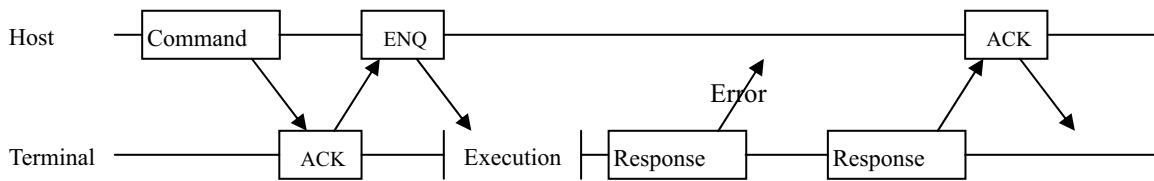
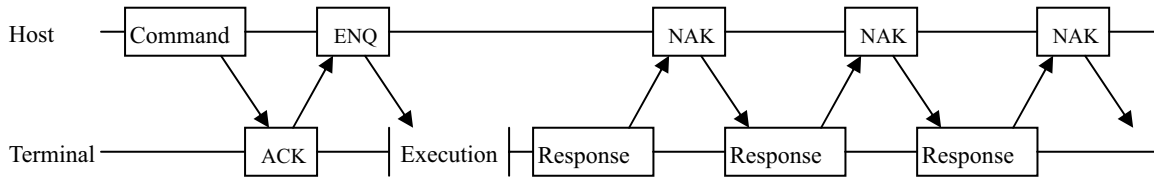

Doc No	CCM-8XXX SERIES SPECIFICATION	REV	PAGE	DATE
9100-0070		A	18/54	2007. 07. 09.

- When received the NAK packet consecutively.

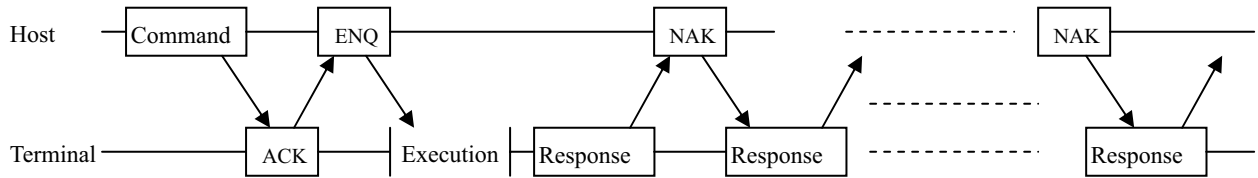

- When the Host sends the command without the ACK packet.

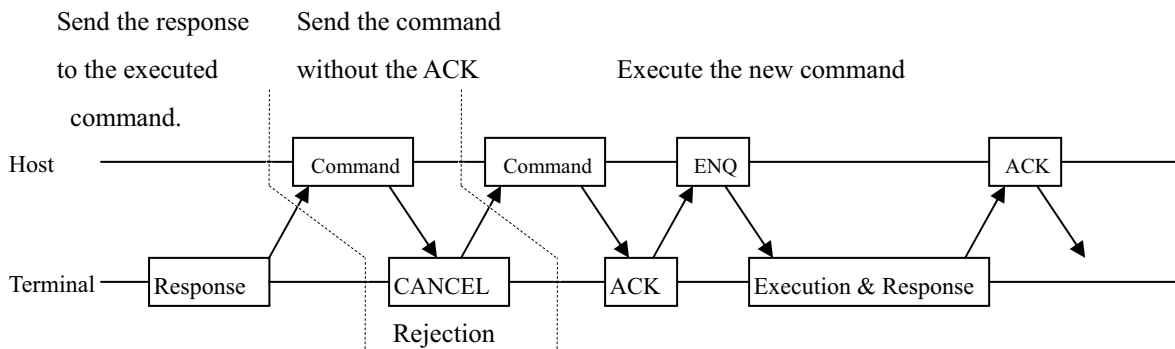

The terminal should ignore the command received before it sends the ACK packet, send the CANCEL packet. The second command will be treated as the ACK packet and executed with no ACK.

Doc No	CCM-8XXX SERIES SPECIFICATION	REV	PAGE	DATE
9100-0070		A	19/54	2007. 07. 09.

TECHNICAL DRAWING

MODEL : CCM-81XX, CCM-82XX, CCM-83XX, CCM-84XX, CCM-85XX, CCM-87XX

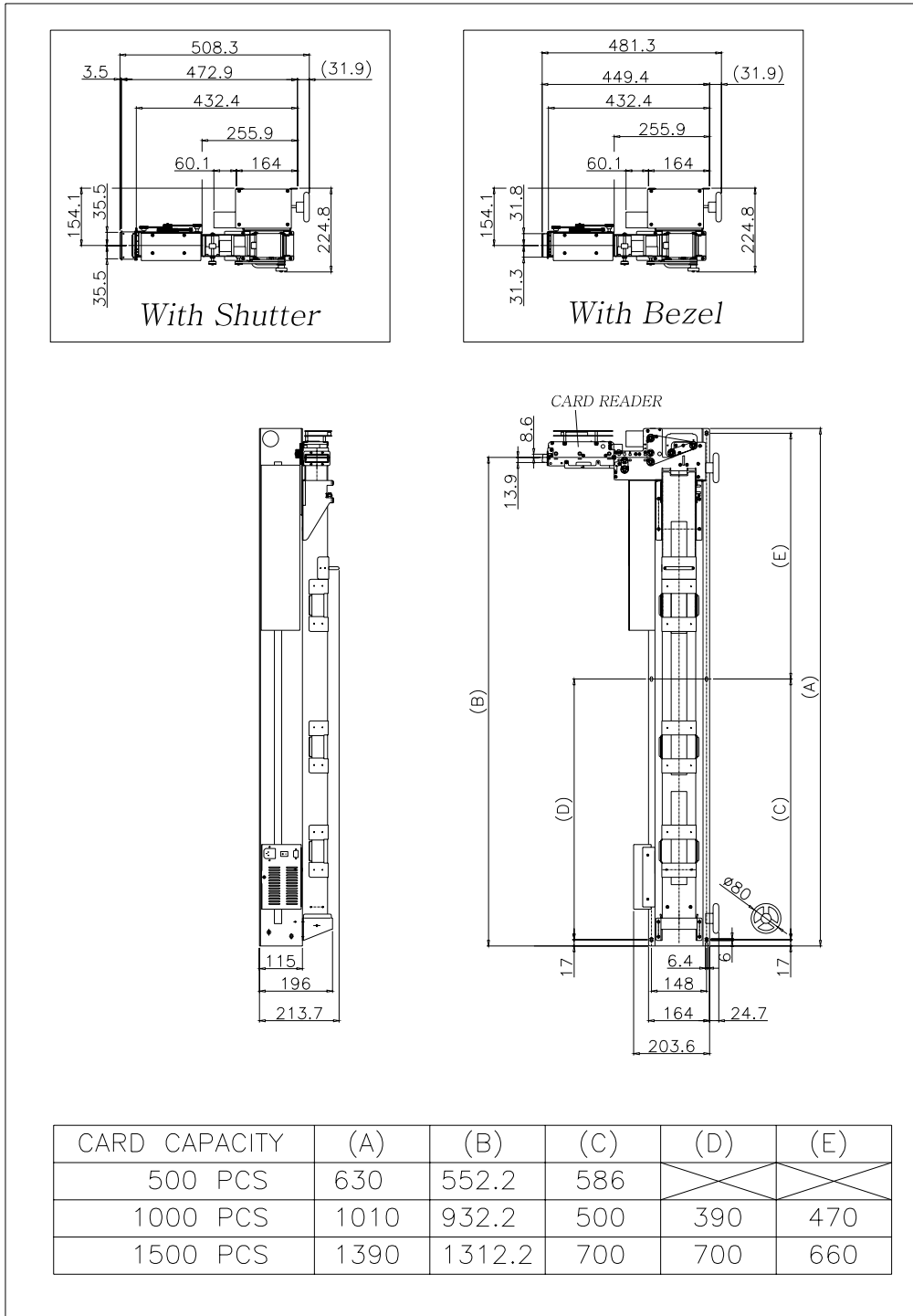

Doc No	CCM-8XXX SERIES SPECIFICATION	REV	PAGE	DATE
9100-0070		A	20/54	2007. 07. 09.

MODEL : CCM-86XX

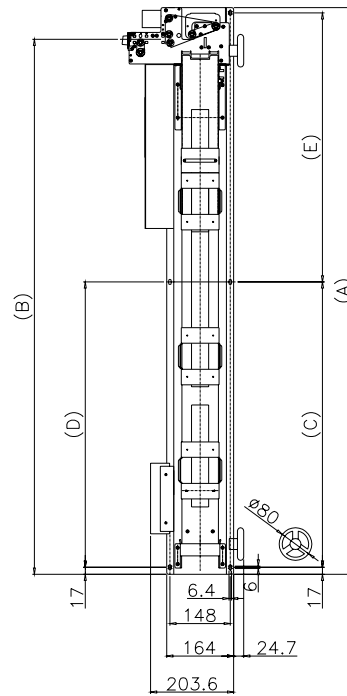
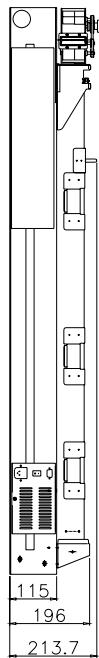
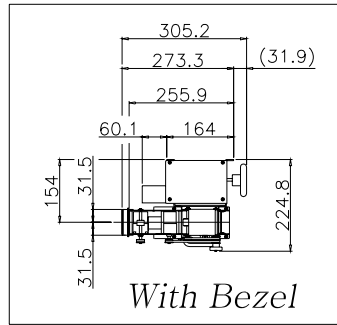
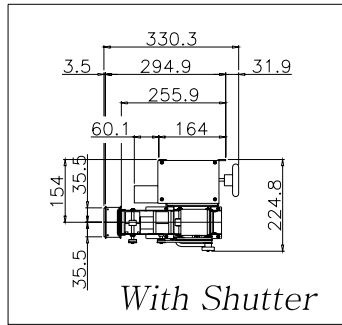

CARD CAPACITY	(A)	(B)	(C)	(D)	(E)
500 EA	630	552.2	586	X	X
1000 EA	1010	932.2	500	390	470
1500 EA	1390	1312.2	700	700	660

Doc No	CCM-8XXX SERIES SPECIFICATION	REV	PAGE	DATE
9100-0070		A	21/54	2007. 07. 09.

<SHUTTER OR BEZEL TYPE FEEDER PART SENSOR POSITION>

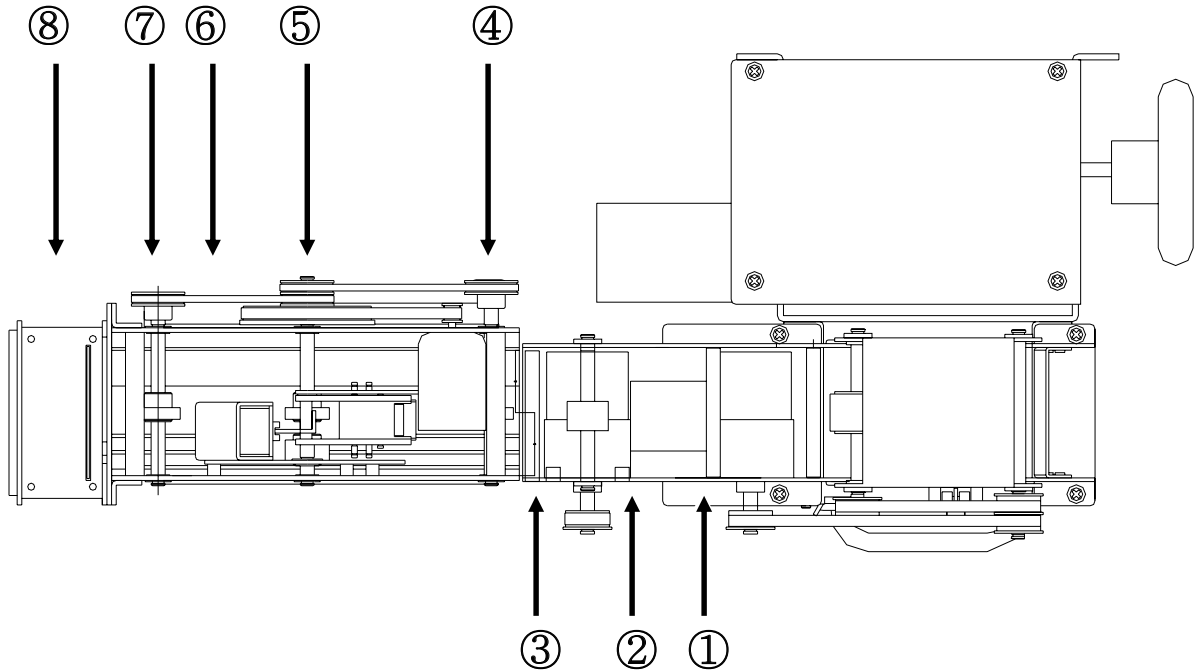

<WITHOUT BEZEL TYPE FEEDER PART SENSOR POSITION>

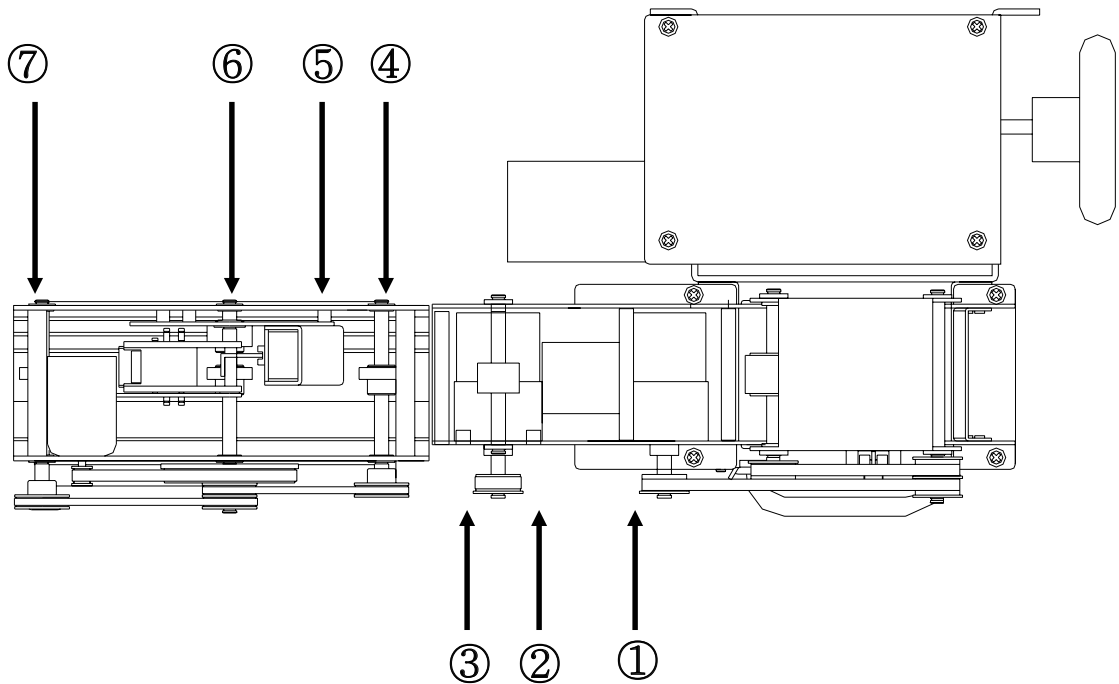

Doc No	CCM-8XXX SERIES SPECIFICATION	REV	PAGE	DATE
9100-0070		A	22/54	2007. 07. 09.

COMMAND DETAIL

◆ *Applicable Models*

Commands	Models	Note
COMMON	All CCM8XXX Series	
MAGNETIC CARD	CCM81XXX, CCM82XXX, CCM83XXX, CCM84XXX	
IC CARD	CCM82XXX, CCM84XXX, CCM85XXX, CCM87XXX	
RF CARD	CCM83XXX, CCM84XXX, CCM86XXX, CCM87XXX	

◆ *Command List*

	Item	Cm0	Cm1	Cm2	Detail	Note
COMMON	STATUS	'C'	'1'	'1'	Get Model	
		'C'	'1'	'2'	Get Firmware Version	
		'C'	'1'	'3'	Get Stacker	
		'C'	'1'	'4'	Get Status List	
		'C'	'1'	'5'	Get Error List	
		'C'	'1'	'6'	Get Card Position	
	SETTING_1	'C'	'2'	'1'	Set RTC IC	Check
		'C'	'2'	'4'	Set Retry Count	Check
		'C'	'2'	'5'	Set Buzz On/Off Cont.	Check
		'C'	'2'	'6'	Set Baud Rate	Check
	SETTING_2	C	'4'	'2'	Software Reset	
	MOVE	'C'	'3'	'2'	Card Move To	
		'C'	'3'	'4'	Card Capture	Backward
		'C'	'3'	'7'	Card Eject (Hold)	Forward
		'C'	'3'	'8'	Raise the Lift	
		'C'	'3'	'9'	Card Move To Stacker	
MAGNETIC CARD	MAGNETIC READ / WRITE	'M'	'3'	'1'	Magnetic Card Read	
		'M'	'3'	'3'	Magnetic Card Write	Verify
		'M'	'3'	'4'	Magnetic Card Write From Stacker	Verify
	CLEANING	'M'	'3'	'5'	Magnetic Card All Track Read	
IC CARD	IC CONTROL	'I'	'2'	'1'	MSRW Header Cleaning	
		'I'	'2'	'2'	IC Card Reset	
RF CARD	RF CARD READ / WRITE	'I'	'2'	'2'	IC Card Direct Control	
		'R'	'3'	'1'	RF Card Read in Block Range	
		'R'	'3'	'2'	RF Card Write in Block Range	Verify
		'R'	'3'	'6'	RF Card Read in Sector Range	
	BALANCE	'R'	'3'	'7'	RF Card Write in Sector Range	
		'R'	'4'	'1'	Balance Increment	
	SECRET KEY CHANGE	'R'	'4'	'2'	Balance Decrement	
		'R'	'5'	'1'	Change 'Secret Key' to other Key	
		'R'	'5'	'2'	Change 'Secret Key' to all the same Key value	
		'R'	'5'	'3'	Select 'Secret Key Index'	
'R'	'5'	'4'	Change 'RF Card Secret Key' to other Key			
'R'	'6'	'1'	Check RF card in antenna area			

Doc No	CCM-8XXX SERIES SPECIFICATION	REV	PAGE	DATE
9100-0070		A	23/54	2007. 07. 09.

◆ *Common*

These are the command set that all the CCM-8XXX Series use. These commands include the terminal setting and the card movement related commands.

The 'STATUS' commands provide the function to check the current terminal status and the errors occurred during the command execution.

The 'SETTING' commands consist of commands for setting the terminal and these commands is easy to use because the same command can use for both setting and checking the terminal.

The 'MOVE' commands consist of commands used commonly like the card eject and capture command.

Commands Set:

Item	Cm0	Cm1	Cm2	Detail	Note
STATUS	'C'	'1'	'1'	Get Model	
	'C'	'1'	'2'	Get Firmware Version	
	'C'	'1'	'3'	Get Stacker	
	'C'	'1'	'4'	Get Status List	
	'C'	'1'	'5'	Get Error List	
	'C'	'1'	'6'	Get Card Position	
SETTING	'C'	'2'	'1'	Set RTC IC	Check
	'C'	'2'	'4'	Set Retry Count	Check
	'C'	'2'	'5'	Set Buzz On/Off Cont.	Check
	'C'	'2'	'6'	Set Baud Rate	Check
	C	'4'	'2'	Software Reset	
MOVE	'C'	'3'	'2'	Card Move To	
	'C'	'3'	'4'	Card Capture	Backward
	'C'	'3'	'7'	Card Eject (Hold)	Forward
	'C'	'3'	'8'	Raise the Lift	
	'C'	'3'	'9'	Card Move To Stacker	

Doc No	CCM-8XXX SERIES SPECIFICATION	REV	PAGE	DATE
9100-0070		A	24/54	2007. 07. 09.

1 STATUS / SETTING

1.1 “C11” : It is to check out Model number of CCM-8XXXX.

☞ Command Format

SOH	Null	Length	STX	“C11”	ETX	Bcc
-----	------	--------	-----	-------	-----	-----

☞ Positive Response Format

SOH	Null	Length	STX	“C11”	GOOD	0x01	DATA	ETX	Bcc
-----	------	--------	-----	-------	------	------	------	-----	-----

☞ Negative Response Format

SOH	Null	Length	STX	“C11”	E-Code	0x00	ETX	Bcc
-----	------	--------	-----	-------	--------	------	-----	-----

☞ Response Data Structure

Model No
30 Byte (ASCII)

1.2 “C12” : It is to check out Firmware Version of CCM-8XXXX

☞ Command Format

SOH	Null	Length	STX	“C12”	ETX	Bcc
-----	------	--------	-----	-------	-----	-----

☞ Positive Response Format

SOH	Null	Length	STX	“C12”	GOOD	0x01	DATA	ETX	Bcc
-----	------	--------	-----	-------	------	------	------	-----	-----

☞ Negative Response Format

SOH	Null	Length	STX	“C12”	E-Code	0x00	ETX	Bcc
-----	------	--------	-----	-------	--------	------	-----	-----

☞ Response Data Structure

VERSION
30 Byte (ASCII)

Doc No	CCM-8XXX SERIES SPECIFICATION	REV	PAGE	DATE
9100-0070		A	25/54	2007. 07. 09.

1.3 “C13” : It is check out status of Stacker of CCM-8XXXX

☞ Command Format

SOH	Null	Length	STX	“C13”	ETX	Bcc
-----	------	--------	-----	-------	-----	-----

☞ Positive Response Format

SOH	Null	Length	STX	“C13”	GOOD	0x01	DATA	ETX	Bcc
-----	------	--------	-----	-------	------	------	------	-----	-----

☞ Negative Response Format

SOH	Null	Length	STX	“C13”	E-Code	0x00	ETX	Bcc
-----	------	--------	-----	-------	--------	------	-----	-----

☞ Response Data Structure

Stacker 1	Stacker 2
1Byte (Hex)	0x00

☞ Data Variable

<Stacker1>

Code	Status
0x01	Stacker #1 Good
0x02	RFU
0x03	Stacker #1 Empty

☞ Note

Stacker Status	Detail
‘Stacker Good’	Too many cards loading ¹⁾
‘Stacker Empty’	No cards in stacker

1) The stacker status is detected by the sensor behind the stacker. The number of cards can be changed.

1.4 “C14” : It is to check out current Status of CCM-8XXXX

☞ Command Format

SOH	Null	Length	STX	“C14”	ETX	Bcc
-----	------	--------	-----	-------	-----	-----

☞ Positive Response Format

SOH	Null	HL	Length	“C14”	GOOD	0x01	DATA	ETX	Bcc
-----	------	----	--------	-------	------	------	------	-----	-----

☞ Negative Response Format

SOH	Null	Length	STX	“C14”	E-Code	0x00	ETX	Bcc
-----	------	--------	-----	-------	--------	------	-----	-----

☞ Response Data Structure

Error Code (1)	---	Error Code (N)				
<table border="1" style="margin: auto;"> <tr> <td style="text-align: center;">High Byte</td> <td style="text-align: center;">Low Byte</td> </tr> <tr> <td colspan="2" style="text-align: center;">2Byte</td> </tr> </table>			High Byte	Low Byte	2Byte	
High Byte	Low Byte					
2Byte						

☞ Note

You can identify the stacker status, motor status, card status (jamming) and communication status through the Error Code in the response data structure.

Doc No	CCM-8XXX SERIES SPECIFICATION	REV	PAGE	DATE
9100-0070		A	26/54	2007. 07. 09.

1.5 “C15” : It is to check out error while Command is being executed.

☞ Command Format

SOH	Null	Length	STX	“C15”	ETX	Bcc
-----	------	--------	-----	-------	-----	-----

☞ Positive Response Format

SOH	Null	Length	STX	“C15”	GOOD	0x01	DATA	ETX	Bcc
-----	------	--------	-----	-------	------	------	------	-----	-----

☞ Negative Response Format

SOH	Null	Length	STX	“C15”	E-Code	0x00	ETX	Bcc
-----	------	--------	-----	-------	--------	------	-----	-----

☞ Response Data Structure

Error Time (1)	Error Code (1)	---	Error Time (N)	Error Code (N)
7Byte (BCD)	2Byte (Hex)	---	7Byte (BCD)	2Byte (Hex)

High Year	Low Year	Month	Day	Hour	Minute	Second
1Byte	1Byte	1Byte	1Byte	1Byte	1Byte	1Byte

High Byte	Low Byte
1Byte	1Byte

☞ Note

This command is only correspond to the error occurred during command execution. The time when an error is occurred is represented to the BCD, while the error code to the HEX.

1.6 “C16” : It is to check out current card position of CCM-8XXXXX.

☞ Command Format

SOH	Null	Length	STX	“C16”	ETX	Bcc
-----	------	--------	-----	-------	-----	-----

☞ Positive Response Format

SOH	Null	Length	STX	“C16”	GOOD	0x01	DATA	ETX	Bcc
-----	------	--------	-----	-------	------	------	------	-----	-----

☞ Negative Response Format

SOH	Null	Length	STX	“C16”	E-Code	0x00	ETX	Bcc
-----	------	--------	-----	-------	--------	------	-----	-----

☞ Response Data Structure

Card Position
1Byte (Hex)

<Card Position>

Number	Code	Sensor
1	0x01	SENSOR 1
2	0x02	SENSOR 2
3	0x04	SENSOR 3
4	0x08	SENSOR 4
5	0x10	SENSOR 5
6	0x20	SENSOR 6
7	0x40	SENSOR 7
8	0x80	SENSOR 8

NOTE: Refer to page 21.

Doc No	CCM-8XXX SERIES SPECIFICATION	REV	PAGE	DATE
9100-0070		A	27/54	2007. 07. 09.

2 SETTING

2.1 “C21” : It is to set or to check ‘RTC IC’.

☞ Command Format

SOH	Null	Length	STX	“C21”	DATA	ETX	Bcc
-----	------	--------	-----	-------	------	-----	-----

☞ Command Data Structure

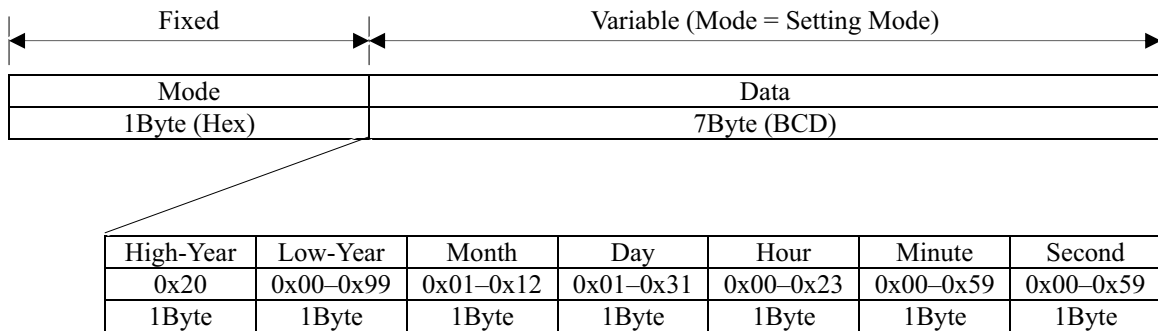

☞ Positive Response Format

SOH	Null	Length	STX	“C21”	GOOD	0x01	DATA	ETX	Bcc
-----	------	--------	-----	-------	------	------	------	-----	-----

☞ Negative Response Format

SOH	Null	Length	STX	“C21”	E-Code	0x00	ETX	Bcc
-----	------	--------	-----	-------	--------	------	-----	-----

☞ Response Data Structure

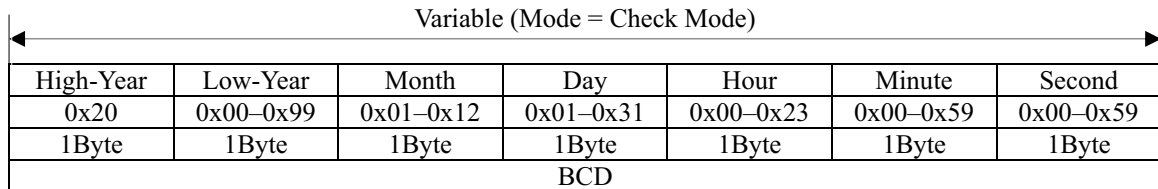

☞ Data Variable

<Mode>

Code	Mode	Detail
0x01	‘Setting Mode’	Set ‘RTC IC’
0x02	‘Check Mode’	Check ‘RTC IC’

☞ Note

‘Day’ is changeable due to the value of ‘Month’.

Doc No	CCM-8XXX SERIES SPECIFICATION	REV	PAGE	DATE
9100-0070		A	28/54	2007. 07. 09.

2.2 “C24” : It is to set or to check ‘Retry Count’.

☞ Command Format

SOH	Null	Length	STX	“C24”	DATA	ETX	Bcc
-----	------	--------	-----	-------	------	-----	-----

☞ Command Data Structure

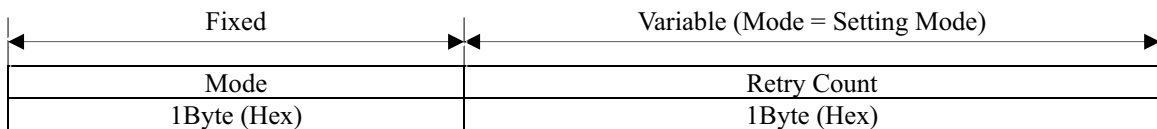

☞ Positive Response Format

SOH	Null	Length	STX	“C24”	GOOD	0x01	DATA	ETX	Bcc
-----	------	--------	-----	-------	------	------	------	-----	-----

☞ Negative Response Format

SOH	Null	Length	STX	“C24”	E-Code	0x00	ETX	Bcc
-----	------	--------	-----	-------	--------	------	-----	-----

☞ Response Data Structure

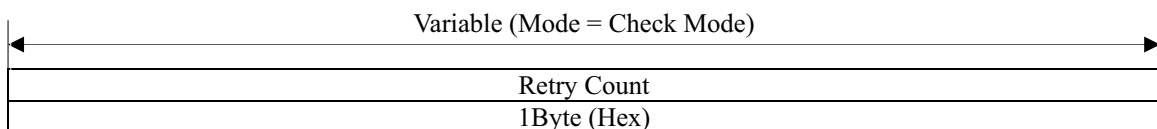

☞ Data Variable

<Mode>

Code	Mode	Detail
0x01	‘Setting Mode’	Set ‘Retry Count’
0x02	‘Check Mode’	Check ‘Retry Count’

<Retry Count>

Code	Setting	Detail	Note
0x00	NON	Do not retry	
0x01	Once	Execute the instruction again.	
0x02	Twice	Retry it twice	
0x03	Three times	Retry it three times	Default

Doc No	CCM-8XXX SERIES SPECIFICATION	REV	PAGE	DATE
9100-0070		A	29/54	2007. 07. 09.

2.3 “C25” : It is to set or to check ‘Buzz Control’.

☞ Command Format

SOH	Null	Length	STX	“C25”	DATA	ETX	Bcc
-----	------	--------	-----	-------	------	-----	-----

☞ Command Data Structure

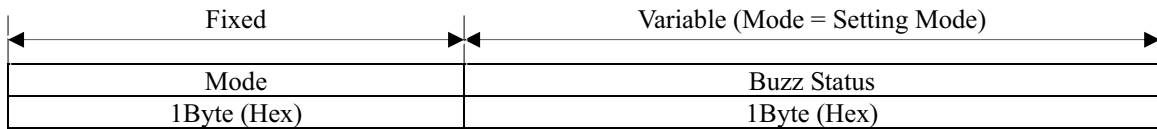

☞ Positive Response Format

SOH	Null	Length	STX	“C25”	GOOD	0x01	DATA	ETX	Bcc
-----	------	--------	-----	-------	------	------	------	-----	-----

☞ Negative Response Format

SOH	Null	Length	STX	“C25”	E-Code	0x00	ETX	Bcc
-----	------	--------	-----	-------	--------	------	-----	-----

☞ Response Data Structure

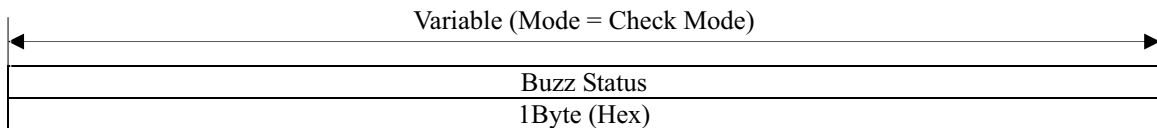

☞ Data Variable

<Mode>

Code	Mode	Detail
0x01	‘Setting Mode’	Set ‘Buzz Control’
0x02	‘Check Mode’	Check ‘Buzz Control’

<Buzz Status>

Code	Setting	Detail	Note
0x01	Buzz Off	Buzz Off	
0x02	Buzz On	Buzz On	Default

Doc No	CCM-8XXX SERIES SPECIFICATION	REV	PAGE	DATE
9100-0070		A	30/54	2007. 07. 09.

2.4 “C26” : It is to change ‘Baud Rate’.

☞ Command Format

SOH	Null	Length	STX	“C26”	DATA	ETX	Bcc
-----	------	--------	-----	-------	------	-----	-----

☞ Command Data Structure

Baud Rate
1Byte (Hex)

☞ Positive Response Format.

SOH	Null	Length	STX	“C26”	GOOD	0x01	ETX	Bcc
-----	------	--------	-----	-------	------	------	-----	-----

☞ Negative Response Format

SOH	Null	Length	STX	“C26”	E-Code	0x00	ETX	Bcc
-----	------	--------	-----	-------	--------	------	-----	-----

☞ Data Variable

<Baud Rate>

Code	Setting	Detail	Note
0x01	9600Bps	Set Baud Rate to be 9600Bps	
0x02	19200Bps	Set Baud Rate to be 19200Bps	
0x03	RFU		
0x04	38400Bps	Set Baud Rate to be 38400Bps	Default
0x05	57600Bps	Set Baud Rate to be 57600Bps	

2.5 “C42” : Software RESET for Main Board.

☞ Command Format.

SOH	Null	Length	STX	“C42”	ETX	Bcc
-----	------	--------	-----	-------	-----	-----

☞ Positive Response Format.

SOH	Null	Length	STX	“C42”	GOOD	0x01	ETX	Bcc
-----	------	--------	-----	-------	------	------	-----	-----

☞ Negative Response Format.

SOH	Null	Length	STX	“C42”	E-Code	0x00	ETX	Bcc
-----	------	--------	-----	-------	--------	------	-----	-----

☞ Note

This “C42” Software RESET command is effective for CCM-8XXX MAIN BOARD only.

Card Dispenser and Card Reader is not RESETed.

With this software RESET, all the data setted at CCM-8XXX return to DEFAULT value.

After “RESET”, minimum 3 seconds is required before running to get secure operation.

Doc No	CCM-8XXX SERIES SPECIFICATION	REV	PAGE	DATE
9100-0070		A	31/54	2007. 07. 09.

3 MOVE.

3.1 “C32” : It is take card to Card Reader / Writer Module.

☞ Command Format

SOH	Null	Length	STX	“C32”	DATA	ETX	Bcc
-----	------	--------	-----	-------	------	-----	-----

☞ Command Data Structure

Module
1Byte (Hex)

☞ Positive Response Format

SOH	Null	Length	STX	“C32”	GOOD	0x01	ETX	Bcc
-----	------	--------	-----	-------	------	------	-----	-----

☞ Negative Response Format

SOH	Null	Length	STX	“C32”	E-Code	0x00	ETX	Bcc
-----	------	--------	-----	-------	--------	------	-----	-----

☞ Data Variable

<Module>

Code	Setting	Detail
0x01	MSRW	Card transport to MSRW Module
0x02	IC	Card transport to IC Module
0x03	RF	Card transport to RF Module

3.2 “C34” : It takes card to Bin Box (Capture).

☞ Command Format.

SOH	Null	Length	STX	“C34”	ETX	Bcc
-----	------	--------	-----	-------	-----	-----

☞ Positive Response Format.

SOH	Null	Length	STX	“C34”	GOOD	0x01	ETX	Bcc
-----	------	--------	-----	-------	------	------	-----	-----

☞ Negative Response Format.

SOH	Null	Length	STX	“C34”	E-Code	0x00	ETX	Bcc
-----	------	--------	-----	-------	--------	------	-----	-----

3.3 “C37” : Dispense the card to front and hold it at the exit roller of the unit.

☞ Command Format

SOH	Null	Length	STX	“C37”	ETX	Bcc
-----	------	--------	-----	-------	-----	-----

☞ Positive Response Format

SOH	Null	Length	STX	“C37”	GOOD	0x01	ETX	Bcc
-----	------	--------	-----	-------	------	------	-----	-----

☞ Negative Response Format

SOH	Null	Length	STX	“C37”	E-Code	0x00	ETX	Bcc
-----	------	--------	-----	-------	--------	------	-----	-----

Doc No	CCM-8XXX SERIES SPECIFICATION	REV	PAGE	DATE
9100-0070		A	32/54	2007. 07. 09.

3.4 “C38” : Raise the Lift.

☞ Command Format

SOH	Null	Length	STX	“C38”	ETX	Bcc
-----	------	--------	-----	-------	-----	-----

☞ Positive Response Format

SOH	Null	Length	STX	“C38”	GOOD	0x01	ETX	Bcc
-----	------	--------	-----	-------	------	------	-----	-----

☞ Negative Response Format

SOH	Null	Length	STX	“C38”	E-Code	0x00	ETX	Bcc
-----	------	--------	-----	-------	--------	------	-----	-----

3.6 “C39” : Move the card to stacker.

☞ Command Format

SOH	Null	Length	STX	“C39”	ETX	Bcc
-----	------	--------	-----	-------	-----	-----

☞ Positive Response Format

SOH	Null	Length	STX	“C39”	GOOD	0x01	ETX	Bcc
-----	------	--------	-----	-------	------	------	-----	-----

☞ Negative Response Format

SOH	Null	Length	STX	“C39”	E-Code	0x00	ETX	Bcc
-----	------	--------	-----	-------	--------	------	-----	-----

Doc No	CCM-8XXX SERIES SPECIFICATION	REV	PAGE	DATE
9100-0070		A	33/54	2007. 07. 09.

◆ *MAGNETIC CARD.*

This section describes the commands that can use at the magnetic card.

The data to be written in every track should be conform to the ISO7816-2 standard, the available character is as follows. For more information about Magnetic card, refer to the ISO7816-2 standard.

Track	Available Character Set	Maximum characters	REMARKS
Track #1	Character, Numbers	76	Except for the special character
Track #2	Numbers	37	
Track #3	Number	104	

The CCM-8XXXX Series provides a feature for speedy processing. The feature is to lessen the processing time for the 'magnetic read' command repeated after latching the data read from card. To latch data occurs at a point of time when verify in the magnetic write command and execute the magnetic read command. However, the latched data is erased when the card is off from the terminal.

The applicable models of the CCM-8XXXX series are the CCM81XXX, CCM82XXX, CCM83XXX, CCM84XXX, the available commands set is as follows.

Item	Cm0	Cm1	Cm2	Detail	Note
MAGNETIC READ/WRITE	'M'	'3'	'1'	Magnetic card one track read	
	'M'	'3'	'3'	Magnetic card one track write	Verify
	'M'	'3'	'4'	Magnetic card write from Stacker	Verify
	'M'	'3'	'5'	Magnetic card all track read	
CLEANING	'M'	'5'	'1'	MSRW Header Cleaning	

Doc No	CCM-8XXX SERIES SPECIFICATION	REV	PAGE	DATE
9100-0070		A	34/54	2007. 07. 09.

Basic Magnetic Card Operations:

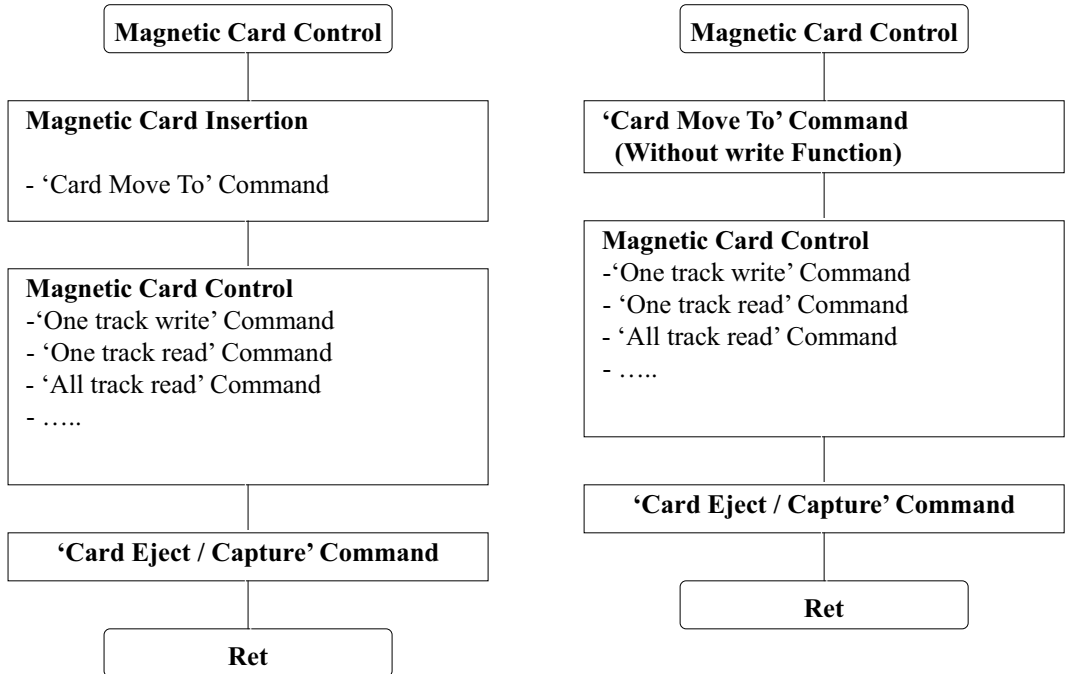

Magnetic Card Operations in the stacker

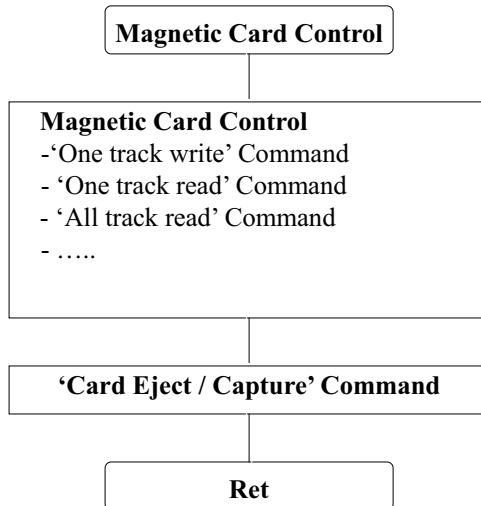

Magnetic Card Operations in the terminal

Doc No	CCM-8XXX SERIES SPECIFICATION	REV	PAGE	DATE
9100-0070		A	35/54	2007. 07. 09.

1 MAGNETIC READ / WRITE.

1.1 “M31” : It is to read data on track chosen.

☞ Command Format

SOH	Null	Length	STX	“M31”	DATA	ETX	Bcc
-----	------	--------	-----	-------	------	-----	-----

☞ Command Data Structure

Track (1Byte)

☞ Positive Response Format

SOH	Null	Length	STX	“M31”	GOOD	0x01	DATA	ETX	Bcc
-----	------	--------	-----	-------	------	------	------	-----	-----

☞ Negative Response Format

SOH	Null	Length	STX	“M31”	E-Code	0x00	ETX	Bcc
-----	------	--------	-----	-------	--------	------	-----	-----

☞ Response Data Structure

Read Data (ASCII Code)

☞ Data Variable

<Track>

Code	Setting	Detail
0x01	Track 1	Read data on Track 1
0x02	Track 2	Read data on Track 2
0x03	Track 3	Read data on Track 3

☞ Note

If the ‘Magnetic Read’ command is executed normally, the read data is latched.

1.2 “M33” : It is to write data on track chosen.

☞ Command Format

SOH	Null	Length	STX	“M33”	DATA	ETX	Bcc
-----	------	--------	-----	-------	------	-----	-----

☞ Command Data Structure

Track	Write Data
1Byte (Hex)	(ASCII Code)

☞ Positive Response Format

SOH	Null	Length	STX	“M33”	GOOD	0x01	ETX	Bcc
-----	------	--------	-----	-------	------	------	-----	-----

☞ Negative Response Format

SOH	Null	Length	STX	“M33”	E-Code	0x00	ETX	Bcc
-----	------	--------	-----	-------	--------	------	-----	-----

☞ Data Variable

<Track>

Code	Setting	Detail
0x01	Track 1	Write data to Track 1
0x02	Track 2	Write data to Track 2
0x03	Track 3	Write data to Track 3

☞ Note

If the ‘Magnetic Write’ command is executed normally, the written data is latched. This command has the ‘Verify’ feature.

Doc No	CCM-8XXX SERIES SPECIFICATION	REV	PAGE	DATE
9100-0070		A	36/54	2007. 07. 09.

1.3 “M34” : It is to take a card from Stacker and to write data to a selected track.

☞ Command Format

SOH	Null	Length	STX	“M34”	DATA	ETX	Bcc
-----	------	--------	-----	-------	------	-----	-----

☞ Command Data Structure

Stacker	Track	Write Data
1Byte (Hex : 0x00)	1Byte (Hex)	(ASCII Code)

☞ Positive Response Format

SOH	Null	Length	STX	“M34”	GOOD	0x01	ETX	Bcc
-----	------	--------	-----	-------	------	------	-----	-----

☞ Negative Response Format

SOH	Null	Length	STX	“M34”	E-Code	0x00	ETX	Bcc
-----	------	--------	-----	-------	--------	------	-----	-----

☞ Data Variable

<Track>

Code	Setting	Detail
0x01	Track 1	Write data to Track 1
0x02	Track 2	Write data to Track 2
0x03	Track 3	Write data to Track 3

☞ Note

This command has the Data ‘Latch ‘and ‘Verify’ features.

1.4 “M35” : It is to read data from all three tracks.

☞ Command Format

SOH	Null	Length	STX	“M35”	ETX	Bcc
-----	------	--------	-----	-------	-----	-----

☞ Positive Response Format

SOH	Null	Length	STX	“M35”	GOOD	0x01	DATA	ETX	Bcc
-----	------	--------	-----	-------	------	------	------	-----	-----

☞ Negative Response Format

SOH	Null	Length	STX	“M35”	E-Code	0x00	ETX	Bcc
-----	------	--------	-----	-------	--------	------	-----	-----

☞ Response Data Structure

0x01 or 0xFF	Track1 Data	0x02 or 0xFF	Track2 Data	0x03 or 0xFF	Track3 Data
1Byte (Hex)	(ASCII)	1Byte (Hex)	(ASCII)	1Byte (Hex)	(ASCII)

☞ Note

If the ‘Magnetic Read’ command is executed normally, the read data is latched.

Doc No	CCM-8XXX SERIES SPECIFICATION	REV	PAGE	DATE
9100-0070		A	37/54	2007. 07. 09.

2 CLEANING

2.1 "M51" : It is to clean Magnetic Head mounted inside MSRW.

☞ Command Format

SOH	Null	Length	STX	"M51"	ETX	Bcc
-----	------	--------	-----	-------	-----	-----

☞ Positive Response Format

SOH	Null	Length	STX	"M51"	GOOD	0x01	ETX	Bcc
-----	------	--------	-----	-------	------	------	-----	-----

☞ Negative Response Format

SOH	Null	Length	STX	"M51"	E-Code	0x00	ETX	Bcc
-----	------	--------	-----	-------	--------	------	-----	-----

Doc No	CCM-8XXX SERIES SPECIFICATION	REV	PAGE	DATE
9100-0070		A	38/54	2007. 07. 09.

◆ *IC CARD.*

This section describes the commands that can use at the IC card and Memory card.

The IC card should conform to the ISO7816-4 T=0 and T=1 , these cards is available

The applicable models in the CCM8XXX Series are the CCM82XXX, CCM82XXX, CCM85XXX, CCM87XXX, and the available commands are as follows.

Item	Cm0	Cm1	Cm2	Detail	Note
IC CONTROL	'1'	'2'	'1'	IC Card Reset	
	'1'	'2'	'2'	IC Card Direct Control	

Select the card Protocol or Speed & IC module baud rate

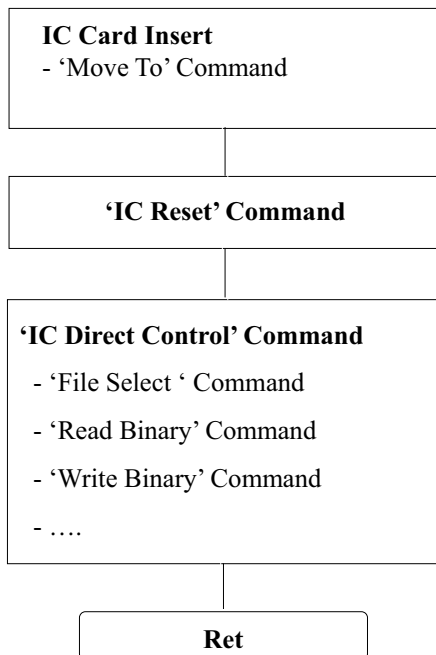

Doc No	CCM-8XXX SERIES SPECIFICATION	REV	PAGE	DATE
9100-0070		A	39/54	2007. 07. 09.

1. IC CONTROL.

1.1 “I21” : Reset the IC card and receive the ATR from card.

☞ Command Format

SOH	Null	Length	STX	“I21”	ETX	Bcc
-----	------	--------	-----	-------	-----	-----

☞ Positive Response Format

SOH	Null	Length	STX	“I21”	GOOD	0x01	DATA	ETX	Bcc
-----	------	--------	-----	-------	------	------	------	-----	-----

☞ Negative Response Format

SOH	Null	Length	STX	“I21”	E-Code	0x00	ETX	Bcc
-----	------	--------	-----	-------	--------	------	-----	-----

☞ Response Data Structure

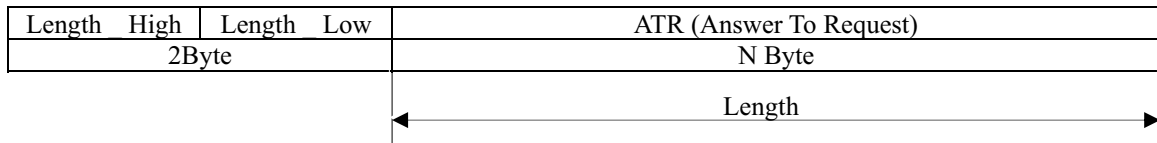

☞ Example

SAMSUNG SCOS ATR

High 8Byte	0x3B	0x6B	0x00	0x00	0x80	0x31	0x80	0x63
Low 7Byte	0x53	0x46	0x01	0x83	0x03	0x90	0x00	

1.2 “I22” : Control the card conforming to the ISO 7816 T = 0 and T =1 , ISO 7816 – 4 standard directly.

☞ Command Format

SOH	Null	Length	STX	“I22”	DATA	ETX	Bcc
-----	------	--------	-----	-------	------	-----	-----

☞ Command Data Structure

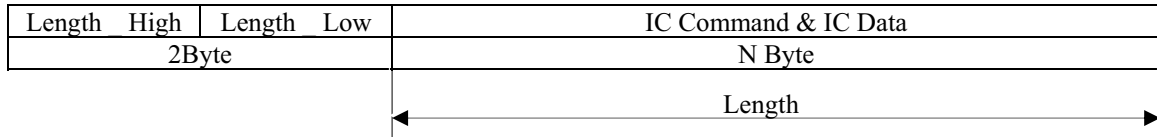

☞ Positive Response Format

SOH	Null	Length	STX	“I22”	GOOD	0x01	DATA	ETX	Bcc
-----	------	--------	-----	-------	------	------	------	-----	-----

☞ Negative Response Format

SOH	Null	Length	STX	“I22”	E-Code	0x00	ETX	Bcc
-----	------	--------	-----	-------	--------	------	-----	-----

☞ Response Data Structure

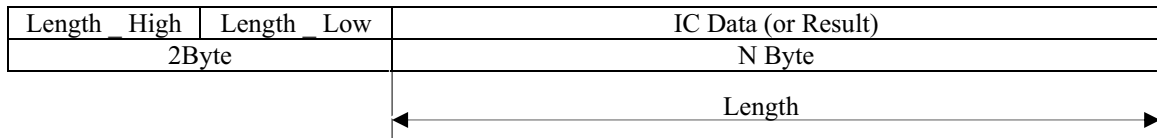

Doc No	CCM-8XXX SERIES SPECIFICATION	REV	PAGE	DATE
9100-0070		A	40/54	2007. 07. 09.

☞ IC Command & IC Data Structure

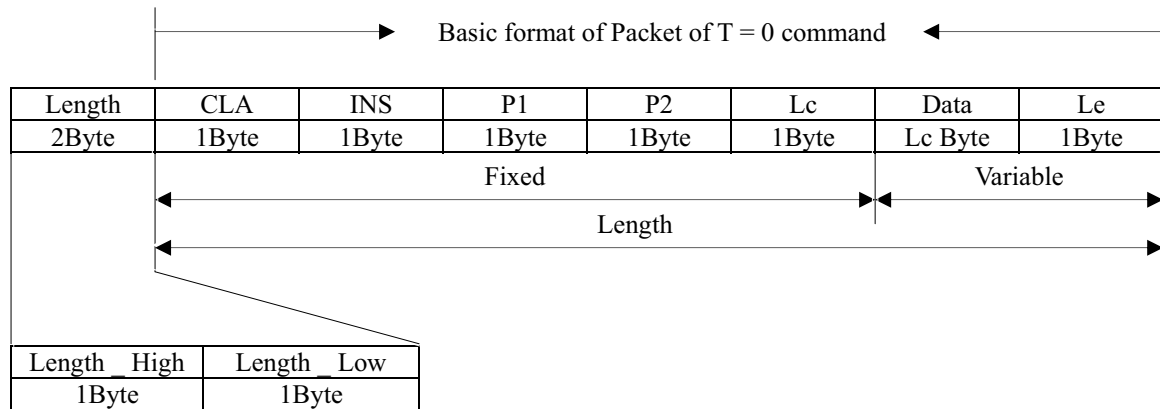

CLA	Class	Note
INS	Instruction	
P1	Offset(High Value)	
P2	Offset(Low Value)	
Lc	A number of data to transfer	Max Value : 255
Data	Data to Transfer	
Le	A number of data to receive	

☞ Format of T = 0 Command

Command	INS Code (Hex Value)
Read Binary Command	B0
Write Binary Command	D0
Update Binary Command	D6
Erase Binary Command	0E
Read Record(s) Command	B2
Write Record Command	D2
Append Record Command	E2
Update Record Command	DC
Get Data Command	CA
Put Data Command	DA
Select File Command	A4
Verify Command	20
Internal Authenticate Command	88
External Authenticate Command	82
Get Challenge Command	84
Manage Channel Command	70

For more information, refer to the ISO 7816 – 4 standard.

Doc No	CCM-8XXX SERIES SPECIFICATION	REV	PAGE	DATE
9100-0070		A	41/54	2007. 07. 09.

◆ *RF CARD*

This section describes the commands that can use at the 'RF CARD'.

The RF Module of his model supports only the MIFARE card.

The applicable models of the CCM8XXXX Series are the CCM84XXX, CCM86XXX, CCM87XXX, the available commands are as follows.

Item	Cm0	Cm1	Cm2	Detail	Note
RF CARD READ /WRITE	'R'	'3'	'1'	Read RF card data in block range	
	'R'	'3'	'2'	Write RF card in block range	
	'R'	'3'	'6'	Read RF card in sector range	
	'R'	'3'	'7'	Write RF card in sector range	
BALANCE	'R'	'4'	'1'	Increment balance in RF card	
	'R'	'4'	'2'	Decrement balance in RF card	
CHANGE SECRET KEY	'R'	'5'	'1'	Change 'Secret Key' to other key	
	'R'	'5'	'2'	Change 'Secret Key' to all the same Key Value	
	'R'	'5'	'3'	Select 'Secret Key Index'	
	'R'	'5'	'4'	Change RF Card 'Secret Key' to other key	
RF DETECT	'R'	'6'	'1'	Check RF card in antenna area	

To use the RF card, you need to initialize at first.

- Setting and updating of the secret key and secret key index.

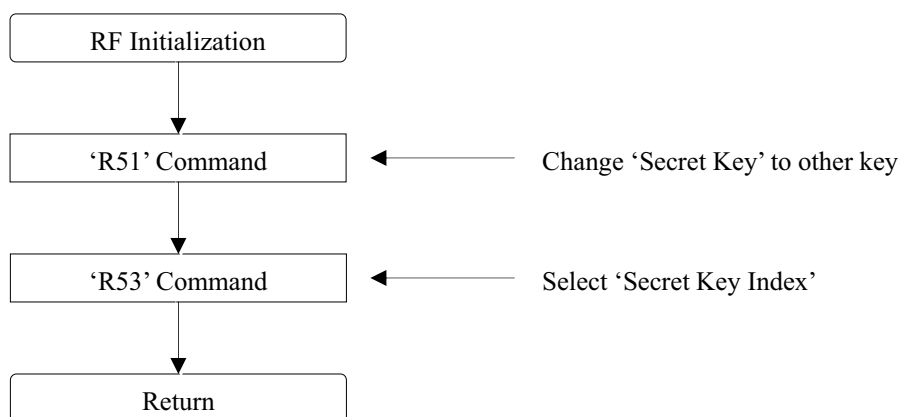

RF Module Initialization

Doc No	CCM-8XXX SERIES SPECIFICATION	REV	PAGE	DATE
9100-0070		A	42/54	2007. 07. 09.

Basic Operating Procedure of the RF card:

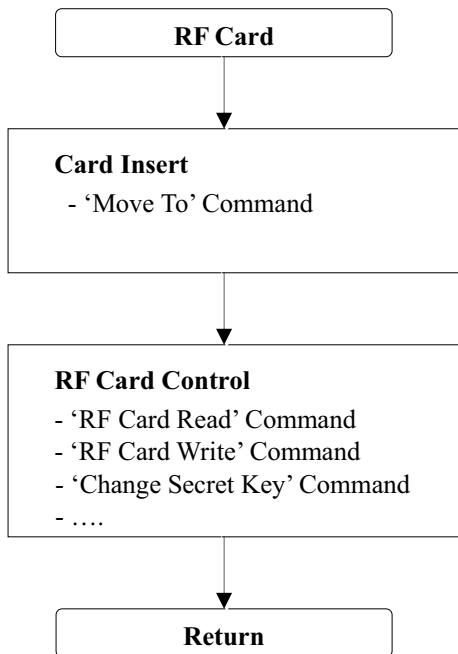

RF Card Basic Operating Procedures

Memory Architecture (map) of the RF card: 8Kbit

Sector	Block	Size	Detail	Note
Sector 0	Block 0	16Byte	RF Card Information	
	Block 1	16Byte		
	Block 2	16Byte		
	Block 3	16Byte	'Sector Key'	Can't use
Sector 1	Block 0	16Byte	User Available Memory	
	Block 1	16Byte		
	Block 2	16Byte		
	Block 3	16Byte	'Sector Key'	Can't use
Sector 2	Block 0	16Byte	User Available Memory	
	Block 1	16Byte		
	Block 2	16Byte		
	Block 3	16Byte	'Sector Key'	Can't use
---	---	---	---	---
Sector 15	Block 0	16Byte	User Available Memory	
	Block 1	16Byte		
	Block 2	16Byte		
	Block 3	16Byte	'Sector Key'	Can't use

Doc No	CCM-8XXX SERIES SPECIFICATION	REV	PAGE	DATE
9100-0070		A	43/54	2007. 07. 09.

1 RF CARD READ / WRITE

1.1 "R31" : Read RF card data & Secret Key in block range

☞ Command Format

SOH	Null	Length	STX	"R31"	DATA	ETX	Bcc
-----	------	--------	-----	-------	------	-----	-----

☞ Command Data Structure

Sector	Block
0x00 – 0x0f	0x00 – 0x03
1Byte (Hex)	1Byte (Hex)

☞ Positive Response Format

SOH	Null	Length	STX	"R31"	GOOD	0x01	DATA	ETX	Bcc
-----	------	--------	-----	-------	------	------	------	-----	-----

☞ Negative Response Format

SOH	Null	Length	STX	"R31"	E-Code	0x00	ETX	Bcc
-----	------	--------	-----	-------	--------	------	-----	-----

☞ Response Data Structure

Sector	Block	Read Data
1Byte (Hex)	1Byte (Hex)	16 Byte (Hex)

D0	D1	D2	---	D14	D15
1Byte	1Byte	1Byte	---	1Byte	1Byte

1.2 "R32" : Write RF card data in block range

☞ Command Format

SOH	Null	Length	STX	"R32"	DATA	ETX	Bcc
-----	------	--------	-----	-------	------	-----	-----

☞ Command Data Structure

Sector	Block	Write Data
0x00 – 0x0f	0x00 – 0x02	0x00 – 0xff
1Byte (Hex)	1Byte (Hex)	16Byte (Hex)

D0	D1	D2	---	D14	D15
1Byte	1Byte	1Byte	---	1Byte	1Byte

☞ Positive Response Format

SOH	Null	Length	STX	"R32"	GOOD	0x01	ETX	Bcc
-----	------	--------	-----	-------	------	------	-----	-----

☞ Negative Response Format

SOH	Null	Length	STX	"R32"	E-Code	0x00	ETX	Bcc
-----	------	--------	-----	-------	--------	------	-----	-----

Doc No	CCM-8XXX SERIES SPECIFICATION	REV	PAGE	DATE
9100-0070		A	44/54	2007. 07. 09.

1.3 “R36” : Read RF card data in sector range

☞ Command Format

SOH	Null	Length	STX	“R36”	DATA	ETX	Bcc
-----	------	--------	-----	-------	------	-----	-----

☞ Command Data Structure

Sector
0x00 – 0x0f
1Byte (Hex)

☞ Positive Response Format

SOH	Null	Length	STX	“R36”	GOOD	0x01	DATA	ETX	Bcc
-----	------	--------	-----	-------	------	------	------	-----	-----

☞ Negative Response Format

SOH	Null	Length	STX	“R36”	E-Code	0x00	ETX	Bcc
-----	------	--------	-----	-------	--------	------	-----	-----

☞ Response Data Structure

Sector	0x00	Read Data (0)	0x01	Read Data (1)	0x02	Read Data (2)
1Byte (Hex)	1Byte (Hex)	16Byte (Hex)	1Byte (Hex)	16Byte (Hex)	1Byte (Hex)	16Byte (Hex)

D0	D1	D2	---	D14	D15
1Byte	1Byte	1Byte	---	1Byte	1Byte

1.4 “R37” : Write RF card data in sector range (except Sector 0)

☞ Command Format

SOH	Null	Length	STX	“R37”	DATA	ETX	Bcc
-----	------	--------	-----	-------	------	-----	-----

☞ Command Data Structure

Sector	Write Data
0x01 – 0x0f	0x00 – 0xff
1Byte (Hex)	51Byte (Hex)

0x00	Read Data (0)	0x01	Read Data (1)	0x02	Read Data (2)
1Byte (Hex)	16Byte (Hex)	1Byte (Hex)	16Byte (Hex)	1Byte (Hex)	16Byte (Hex)

D0	D1	D2	---	D14	D15
1Byte	1Byte	1Byte	---	1Byte	1Byte

☞ Positive Response Format

SOH	Null	Length	STX	“R37”	GOOD	0x01	ETX	Bcc
-----	------	--------	-----	-------	------	------	-----	-----

☞ Negative Response Format

SOH	Null	Length	STX	“R37”	E-Code	0x00	ETX	Bcc
-----	------	--------	-----	-------	--------	------	-----	-----

Doc No	CCM-8XXX SERIES SPECIFICATION	REV	PAGE	DATE
9100-0070		A	45/54	2007. 07. 09.

2 BALANCE

2.1 “R41” : Increment the balance of card to the specified amount.

☞ Command Format

SOH	Null	Length	STX	“R41”	DATA	ETX	Bcc
-----	------	--------	-----	-------	------	-----	-----

☞ Command Data Structure

Sector	Block	Index Value
0x00 – 0x0f	0x00 – 0x02	0x00000000 – 0xffffffff
1Byte (Hex)	1Byte (Hex)	4Byte (Hex)

V0	V1	V2	V3
0x00-0xff	0x00-0xff	0x00-0xff	0x00-0xff
1Byte(Hex, LSB)	1Byte(Hex)	1Byte(Hex)	1Byte(Hex, MSB)

☞ Positive Response Format

SOH	Null	Length	STX	“R41”	GOOD	0x01	ETX	Bcc
-----	------	--------	-----	-------	------	------	-----	-----

☞ Negative Response Format

SOH	Null	Length	STX	“R41”	E-Code	0x00	ETX	Bcc
-----	------	--------	-----	-------	--------	------	-----	-----

☞ Note

The balance should be written in the Electronic Purse format in the card.

2.1 “R42” : Decrement the balance of card to the specified amount..

☞ Command Format

SOH	Null	Length	STX	“R42”	DATA	ETX	Bcc
-----	------	--------	-----	-------	------	-----	-----

☞ Command Data Structure

Sector	Block	Index Value
0x00 – 0x0f	0x00 – 0x02	0x00000000 – 0xffffffff
1Byte (Hex)	1Byte (Hex)	4Byte (Hex)

V0	V1	V2	V3
0x00-0xff	0x00-0xff	0x00-0xff	0x00-0xff
1Byte(Hex, LSB)	1Byte(Hex)	1Byte(Hex)	1Byte(Hex, MSB)

☞ Positive Response Format

SOH	Null	Length	STX	“R42”	GOOD	0x01	ETX	Bcc
-----	------	--------	-----	-------	------	------	-----	-----

☞ Negative Response Format

SOH	Null	Length	STX	“R42”	E-Code	0x00	ETX	Bcc
-----	------	--------	-----	-------	--------	------	-----	-----

☞ Note

The balance should be written in the Electronic Purse format in the card.

Doc No	CCM-8XXX SERIES SPECIFICATION	REV	PAGE	DATE
9100-0070		A	46/54	2007. 07. 09.

3 SECRET KEY.

3.1 “R51” : Change ‘Secret Key’ to a new key

☞ Command Format

SOH	Null	Length	STX	“R51”	DATA	ETX	Bcc
-----	------	--------	-----	-------	------	-----	-----

☞ Command Data Structure

Sector	KEY A	KEY B
0x00 – 0x0f	0x00 – 0xff	0x00 – 0xff
1Byte (Hex)	6Byte (Hex)	6Byte (Hex)

☞ Positive Response Format

SOH	Null	Length	STX	“R51”	GOOD	0x01	ETX	Bcc
-----	------	--------	-----	-------	------	------	-----	-----

☞ Negative Response Format

SOH	Null	Length	STX	“R51”	E-Code	0x00	ETX	Bcc
-----	------	--------	-----	-------	--------	------	-----	-----

☞ Note

CCM-8XXX Series ‘Secret Key’ Default

KEY A : FFFFFFFFFF

KEY B : FFFFFFFFFF

3.2 “R52” : Change ‘Secret Key’ to all the same key value

☞ Command Format

SOH	Null	Length	STX	“R52”	DATA	ETX	Bcc
-----	------	--------	-----	-------	------	-----	-----

☞ Command Data Structure

KEY A	KEY B
0x00 – 0xff	0x00 – 0xff
6Byte (Hex)	6Byte (Hex)

☞ Positive Response Format

SOH	Null	Length	STX	“R52”	GOOD	0x01	ETX	Bcc
-----	------	--------	-----	-------	------	------	-----	-----

☞ Negative Response Format

SOH	Null	Length	STX	“R52”	E-Code	0x00	ETX	Bcc
-----	------	--------	-----	-------	--------	------	-----	-----

☞ Note

CCM-8XXX Series ‘Secret Key’ Default

KEY A : FFFFFFFFFF

KEY B : FFFFFFFFFF

Doc No	CCM-8XXX SERIES SPECIFICATION	REV	PAGE	DATE
9100-0070		A	47/54	2007. 07. 09.

3.3 “R53” : Select ‘Secret Key Index’

☞ Command Format

SOH	Null	Length	STX	“R53”	DATA	ETX	Bcc
-----	------	--------	-----	-------	------	-----	-----

☞ Command Data Structure

Index
0x01 – 0x02
1Byte (Hex)

☞ Positive Response Format

SOH	Null	Length	STX	“R53”	GOOD	0x01	ETX	Bcc
-----	------	--------	-----	-------	------	------	-----	-----

☞ Negative Response Format

SOH	Null	Length	STX	“R53”	E-Code	0x00	ETX	Bcc
-----	------	--------	-----	-------	--------	------	-----	-----

☞ Data Variable

<Index>

Code	Setting	Detail
0x01	KEY A	Select ‘Secret Key A’
0x02	KEY B	Select ‘Secret Key B’

☞ Note

CCM-8XXX Series ‘Secret Key Index’ Default

‘Secret Key Index ‘ : KEY A

3.4 “R54” : Change RF card ‘Secret Key’ to other key

☞ Command Format

SOH	Null	Length	STX	“R54”	DATA	ETX	Bcc
-----	------	--------	-----	-------	------	-----	-----

☞ Command Data Structure

- Command data structure without ‘Access Condition’

Sector	KEY A	KEY B
0x00 – 0x0f	0x00 – 0xff	0x00 – 0xff
1Byte (Hex)	6Byte (Hex)	6Byte (Hex)

- Command data structure with ‘Access Condition’

Sector	KEY A	Access	KEY B
0x00 – 0x0f	0x00 – 0xff	0x00 – 0xff	0x00 – 0xff
1Byte (Hex)	6Byte (Hex)	4Byte (Hex)	6Byte (Hex)

☞ Positive Response Format

SOH	Null	Length	STX	“R54”	GOOD	0x01	ETX	Bcc
-----	------	--------	-----	-------	------	------	-----	-----

☞ Negative Response Format

SOH	Null	Length	STX	“R54”	E-Code	0x00	ETX	Bcc
-----	------	--------	-----	-------	--------	------	-----	-----

☞ Warning

If you use this command incorrectly, it couldn’t be authenticated from the card.

Doc No	CCM-8XXX SERIES SPECIFICATION	REV	PAGE	DATE
9100-0070		A	48/54	2007. 07. 09.

4 RF DETECT.

4.1 "R61" : RF card detect in antenna area

☞ Command Format

SOH	Null	Length	STX	"R61"	ETX	Bcc
-----	------	--------	-----	-------	-----	-----

☞ Positive Response Format

SOH	Null	Length	STX	"R61"	GOOD	DATA	0x01	ETX	Bcc
-----	------	--------	-----	-------	------	------	------	-----	-----

☞ Negative Response Format

SOH	Null	Length	STX	"R61"	E-Code	0x00	ETX	Bcc
-----	------	--------	-----	-------	--------	------	-----	-----

☞ Response Data Structure

Serial Number
Hex Code
4Byte

☞ Note

If the RF card is detected, this command send the serial number to host. But, it doesn't authenticate the Secret Key of the RF card.

Doc No	CCM-8XXX SERIES SPECIFICATION	REV	PAGE	DATE
9100-0070		A	49/54	2007. 07. 09.

ERROR DETAIL

<GOOD>

Code : 0x0000

Description: Normal Execution

Procedures: None

<NOT_DEFINE_COMMAND>

Code : 0x2001

Description : Using the command that does not defined in this model.

Action : Use the valid command in this model.

<NOT_USE_COMMAND>

Code : 0x2002

Description : Not available command in this model.

Action : Use the valid command in this model.

<COMM_FRAME_ERROR>

Code : 0x2003

Description : Sending the command that has the invalid communication frame.

Action : Check the data format and the corresponding module specification.

<CARD_JAM>

Code : 0x2004

Description : When the card is jammed.

Action : Remove the jammed card.

<NO_CARD>

Code : 0x2005

Description : No cards.

Action : Insert the card.

Doc No	CCM-8XXX SERIES SPECIFICATION	REV	PAGE	DATE
9100-0070			A	50/54

<CARD_PRESENT>

Code : 0x2006

Description : When the card exists already in the terminal.

Action : Eject the card.

<RTC_ERROR>

Code : 0x2008

Description : When the RTC chip is broken.

Action : Replace the board.

<TWO_CARD_ERROR>

Code : 0x2009

Description : When more than one card is presented in the feeder part.

Action : Remove one card.

< CARTRIDGE_JAM_ERROR>

Code : 0x200c

Description : When the cartridge is jammed.

Action : Check if the lift and the motor is normal.

< NO_CARTRIDGE_ERROR>

Code : 0x200d

Description : When the cartridge is not presented.

Action : Equip the cartridge.

< INVALID_POS_ERROR>

Code : 0x200e

Description : When the card is presented in the invalid position for the received command.

Action : Transmit another command.

<DISPENSER_ERROR>

Code : 0x2100

Description : Not Applicable Dispenser.

Action : Reset the terminal and exchange the dispenser..

Doc No	CCM-8XXX SERIES SPECIFICATION	REV	PAGE	DATE
9100-0070		A	51/54	2007. 07. 09.

<DISPENSER_COMM_ERROR>

Code : 0x2101

Description : Dispenser communication error

Action : Check the communication line and reset the terminal.

<STACKER_ERROR>

Code : 0x2102

Description : The first STACKER ERROR

Action : Be sure that the card is loaded at the first stacker.

<STACKER_EMPTY>

Code : 0x2105

Description : No card at the first stacker.

Action : Load the card at the first stacker.

<CHARGING_SENSOR_ERROR>

Code : 0x211a

Description : An error is occurred in one sensor between two charging sensor.

Action : replace the charging sensor.

<DISPENSER_STOP>

Code : 0x211d

Description : Operation has been stopped because of Main Motor Stop Sensor Detection or both of charging sensor error.

Action : Check the lift. Or replace the charging sensor.

<MSRW_ERROR>

Code : 0x2200

Description : The Card Reader/Writer that cannot use in this model.

Action : Change the Card Reader/Writer.

<MSRW_COMM_ERROR>

Code : 0x2201

Description : The Card Reader/Writer communication error.

Action : Check the communication line and reset the terminal.

Doc No	CCM-8XXX SERIES SPECIFICATION	REV	PAGE	DATE
9100-0070			A	52/54

<MSRW_WRITE_ERROR>

Code : 0x2202

Description : Error when the MS Reader/Writer is writing on the card.

Action : Clean the header and check the card.

<MSRW_READ_ERROR>

Code : 0x2203

Description : Error when the MS Reader/Writer is reading on the card.

Action : Clean the header and check the card.

<IC_CONTACT_ERROR>

Code : 0x2204

Description : Error while the terminal contacts the IC card.

Action : Be sure that the current card is an IC card.

<IC_CONTROL_ERROR>

Code : 0x2205

Description : Error while the terminal executes the IC card command.

Action : Check if the command is able to use in the contacted card.

<MSRW_BLANK_ERROR >

Code : 0x2209

Description : The respective block of the MS card is blank.

Action : Write the respective black . Or read other written card.

<RF_ERROR>

Code : 0x2300

Description : Unavailable RF module.

Action : Change the RF MODULE

<RF_COMM_ERROR>

Code : 0x2301

Description : Communication error at the RF Module.

Action : Check the connection socket

Doc No	CCM-8XXX SERIES SPECIFICATION	REV	PAGE	DATE
9100-0070		A	53/54	2007. 07. 09.

<RF_AUTHEN_ERROR>

Code : 0x2302

Description : Authentication Error at the RF Module.

Action : Change the 'SECRET KEY'

<RF_WRITE_ERROR>

Code : 0x2303

Description : Error while the terminal writes at the RF Card.

Action : Be sure that the card exists in the detection range.

<RF_READ_ERROR>

Code : 0x2304

Description : Error while the terminal reads at the RF Card.

Action: Be sure that the card exists in the detection range.

<RF_DETECT_ERROR>

Error Code : 0x2305

Description : No RF Card.

Action : Insert the RF Card into the terminal.

<RF_AMOUNT_ERROR>

Error Code : 0x2306

Description : Error while the terminal increases(or decreases) the balance at the RF card.

Action : Tune the RF module

Doc No	CCM-8XXX SERIES SPECIFICATION	REV	PAGE	DATE
9100-0070		A	54/54	2007. 07. 09.

Precautions

1. Check if the card exists in stacker. Otherwise, it may not issue the card.

2. Check the communication line
 - 1) Communication Port, Baud, Parity, and Data Bit, etc.