



Ingeniería Electrónica
SMART IDENT

CARD COLLECTING MACHINE

Specifications

User Manual

CCM-2000 Rev. F

Doc No	CCM2000 SPECIFICATION	REV	PAGE	DATE
90000130		F	2 OF 57	2011. 03.08.

Card Collecting Machine for Magnetic, Contact & IC Card

Doc No	CCM2000 SPECIFICATION	REV	PAGE	DATE
90000130		F	3 OF 57	2011. 03.08.

REVISION HISTORY

No	DATE	DESCRIPTION	REV	PAGE	F/W Name
1	2007.05.06.	The first	A	51	
2	2007.08.15	TTL Interface addition	B	55	
3	2007.10.01	Technical drawing addition.	C	55	
4	2008.04.07	1. Change the Baud Rate Setting Method	D	54	
		2. Remove Commands"R55 and R56".			
		3. Card Position Change.			
		4. Add Error Code (2503,2505).			
5	2008.04.20	Add Mifare 4k	E	57	
6	2011.03.08	Configuration table change	F	57	

Doc No	CCM2000 SPECIFICATION	REV	PAGE	DATE
90000130		F	4 OF 57	2011. 03.08.

MODEL NAME INFORMATION

C C M - 2

INTERFACE	FUNCTION	MS / IC / RF	TRACK	OPTION	CAPACITY			OPTION II
RS-232C	2: SINGLE CARTRIDGE COLLECTING MACHINE	0 : - 1 : MS ONLY 2 : MS & IC-CONTACT 3 : MS & RF 4 : MS & IC & RF 5 : IC-CONTACT ONLY 6 : RF ONLY 7 : IC & RF 8 : RF Only	0: WITHOUT MAGNETIC 1: ISO 1 TRK 2: ISO 2 TRK 3: ISO 3 TRK 4: ISO 1,2 TRK 5: ISO 1,3 TRK 6: ISO 2,3 TRK 7: ISO 1,2,3 TRK	0: WITHOUT BEZEL 1: LOW-CO SHORT BEZEL 2: HI-CO SHORT BEZEL 3: LOW-CO & SHUTTER 4: HI-CO & SHUTTER 5: SHUTTER 6: SHORT BEZEL 7: LOW-CO WITHOUT BEZEL 8: HI-CO WITHOUT BEZEL	A: 0.2T B: 0.38T C: 0.5T D: 0.76T E: 0.84T F: 1.0T	G: 0.2T H: 0.38T I: 0.5T J: 0.76T K: 0.84T L: 1.0T	M: 0.2T N: 0.38T O: 0.5T P: 0.76T Q: 0.84T R: 1.0T	0:- H:HI-CO&LOW-CO SELECTOR
					200 PCS	300 PCS	500 PCS	

Doc No	CCM2000 SPECIFICATION	REV	PAGE	DATE
90000130		F	5 OF 57	2011. 03.08.

C O N T E N T S

Overview

System Block Diagram

Specification

Magnetic Card Process

IC Card Process

RF Card Process

Communication Interface

Technical Drawing

Command Detail

Error Detail

Doc No	CCM2000 SPECIFICATION	REV	PAGE	DATE
90000130		F	6 OF 57	2011. 03.08.

OVERVIEW

CCM-2000 Series is a set of card collecting machine for the magnetic, IC, and RF card in conjunction with the CMT1000 and KYT3000 series. This model can be used for magnetic card conforming to the ISO7816-2 standard and most of the IC cards conforming with the ISO7816-4 T=0. Additionally, this model also can be used for RF card conforming to the MIFARE.

SYSTEM BLOCK DIAGRAM

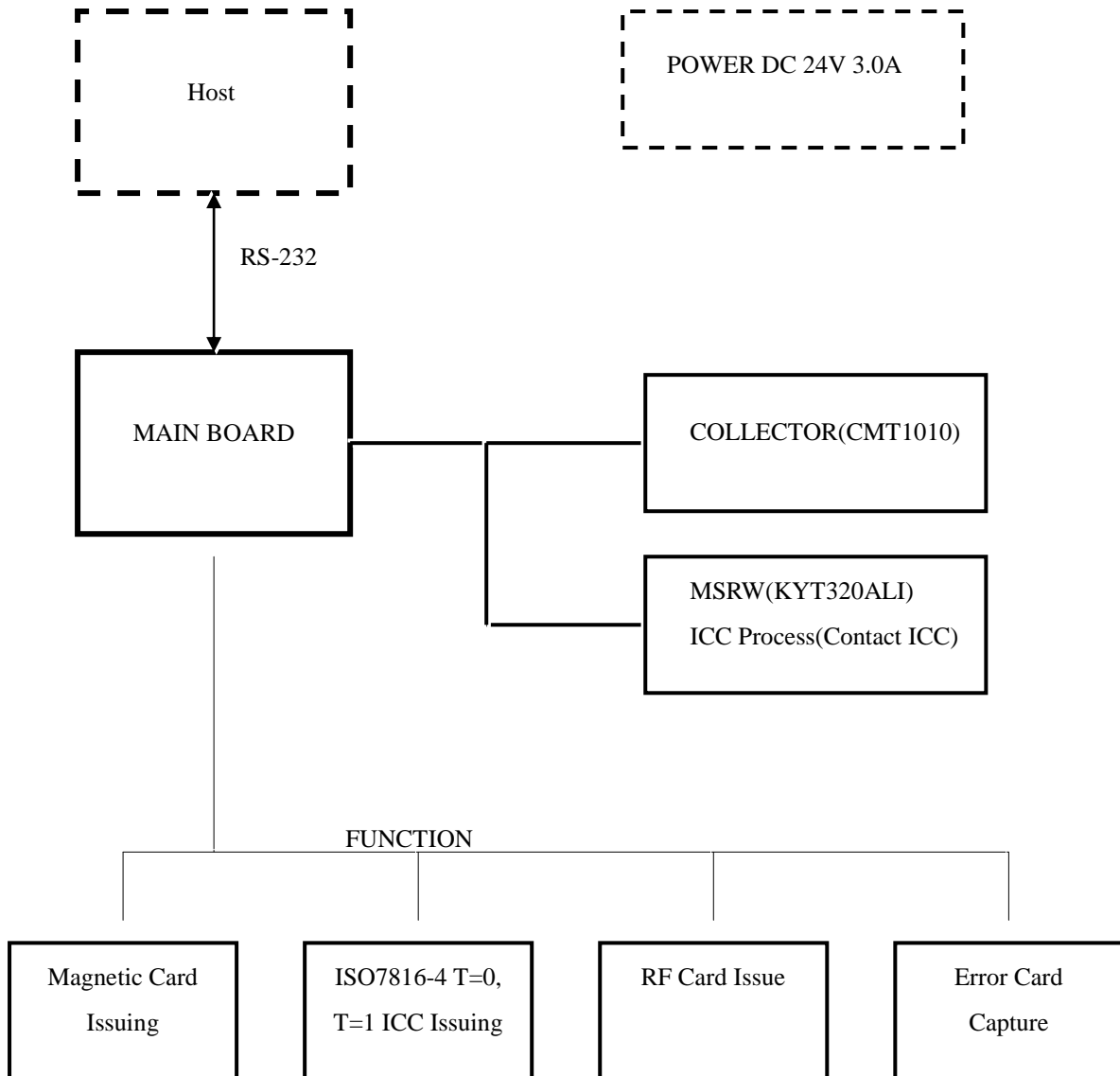

Doc No	CCM2000 SPECIFICATION	REV	PAGE	DATE
90000130		F	7 OF 57	2011. 03.08.

◆ *RS – 232 Connection*

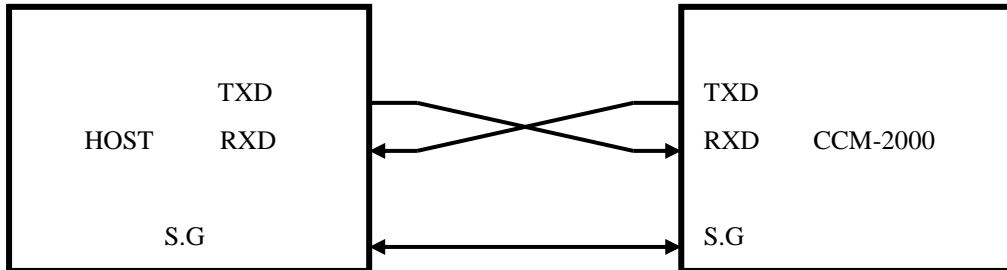

CASE 1) Part Number : D-SUB CONNECTOR(FEMALE)

Pin No	INDEX	Remark
2	RXD	Receive
3	TXD	Transmit
5	S.G	Signal Ground

◆ *RS422 Connection*

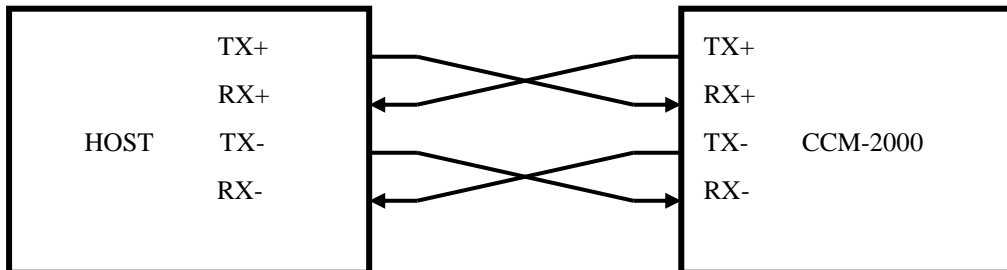

CASE 1) Part Number : D-SUB CONNECTOR(FEMALE)

Pin No	INDEX	Remark
1	TX+-	
4	RX+	
6	TX-	
8	RX-	

Doc No	CCM2000 SPECIFICATION	REV	PAGE	DATE
90000130		F	8 OF 57	2011. 03.08.

◆ *Power Connection*

Front View (male)

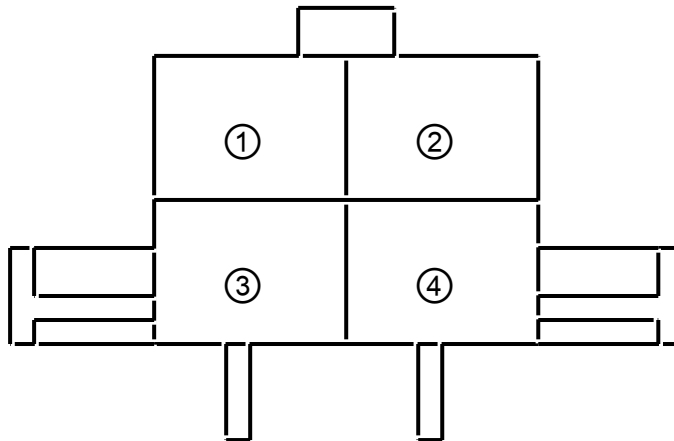

Part Number : 5566-04A1 (MOLEX)

<CCM-2000>

Pin No	Signal Name	Direction
1		INPUT
2	DC +24V	
3		
4	GND	

Doc No	CCM2000 SPECIFICATION	REV	PAGE	DATE
90000130		F	9 OF 57	2011. 03.08.

SPECIFICATIONS

◆ *basic functions*

	Spec	Remark
Dimension		
Weight		
Input power	DC 24V 3A	
Card Feeding Speed	340mm/Sec ±10%	

◆ *Environment Requirements*

Operating Locus : in door use Only

Ambient Temperature

Storage : -20 °C to 70 °C(No functional error to be found in 12 hours after returning to normal environment)

Operating : 5 °C to 50°C (In 0°C to +5°C range, all specifications but 'Warped card' to be satisfied)

Ambient Relative Humidity

Storage : 0% to 95% RH(No functional error to be found in 12 hours after returning to normal environment)

Operating : 5 % 90% RH(No Condensation)

Vibration

: Amplitude 2mm, 10 to 50 Hz in X, Y, Z directions for 30min, 2G or less

Shock Endurance

: 30G, 11ms

Encoding Speed : 2.3 ~ 5 Sec/Card

Life Time : More than 500,000card passes(1pass : one forward and backward)

Error Rate : Less than 3/1,000 cycle(Test Card : KYT Standard)

Doc No	CCM2000 SPECIFICATION	REV	PAGE	DATE
90000130		F	10 OF 57	2011. 03.08.

◆ *Controller Environment*

1.Communication

: RS422 OR RS232C Interface

: Baud Rate – 9600 BPS

19200 BPS

38400BPS (Default)

57600BPS

: 8Data bit, 1 Start bit, None Parity bit, 1 Stop Bit

2.DIP-SWITCH SETTING

:To provide basic operation and function setting of terminal, DIP(Dual In type Package) switch in the main board has selection of main program and function of communication speed setting.

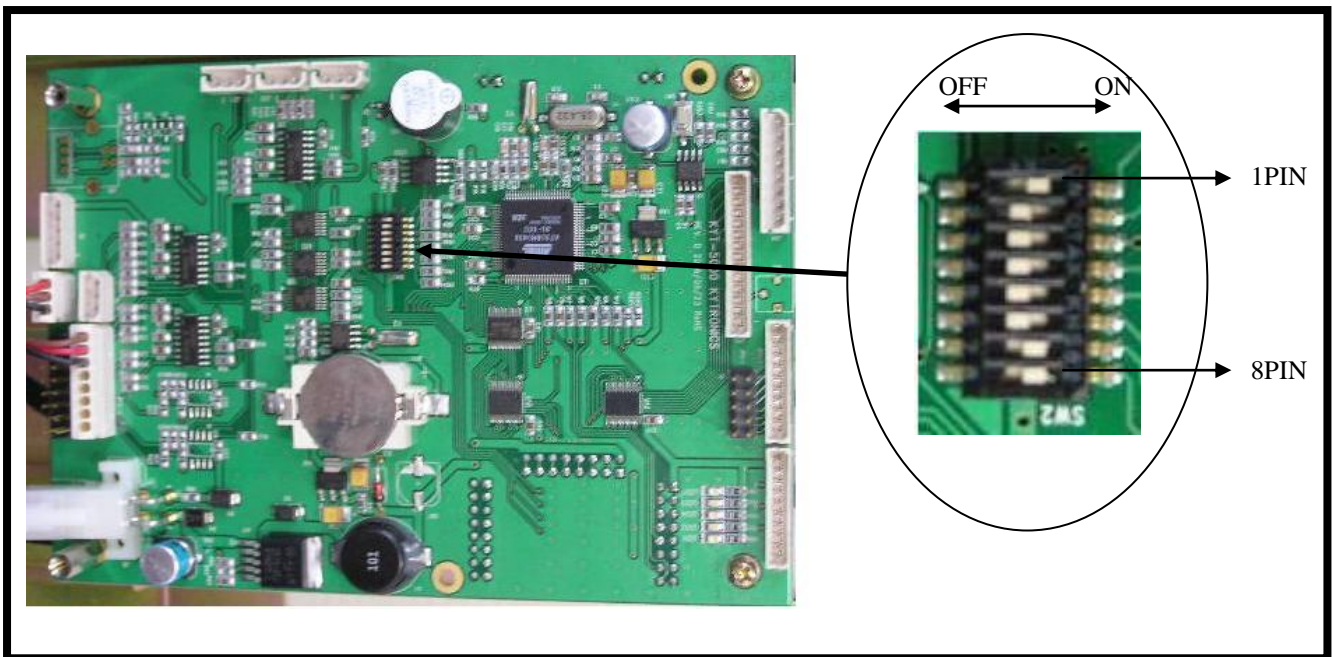

2-1 PIN SETTING

PIN NO. 1	Pin NO.2~NO.6	PIN NO. 7	PIN NO. 8	Baud Rate	Remark
ON	OFF	OFF	OFF	9600 BPS	
ON	OFF	OFF	ON	19200 BPS	
ON	OFF	ON	OFF	38400 BPS	Default
ON	OFF	ON	ON	57600 BPS	

Doc No	CCM2000 SPECIFICATION	REV	PAGE	DATE
90000130		F	11 OF 57	2011. 03.08.

MAGNETIC CARD PROCESS

◆ *Total processing time*

: Less than 1.2 Sec

◆ *Life and Reliability*

Life of Head : Minimum 1,000,000 passes

(One pass is for forward and backward movement)

Error Rate : 3/1000 cycle

◆ *Reference Standards*

: ISO 7811-1,2,3,4,5 : identification cards – Recording technique

◆ *Recording*

	ISO Track 1	ISO Track 2	ISO Track 3
BPI	210	75	210
Capacity	Max 79	Max 40	Max 107
Reading Methods	F2F		
Length	Variable		
Card thickness	Plastic : 0.76 ±0.08mm		

◆ *Warped Cards*

: This term refers to an evenly warped card having a height from the top of the convex surface to the base of the warped edge.



H : 3.00mm Max. for card jamming

Doc No	CCM2000 SPECIFICATION	REV	PAGE	DATE
90000130		F	12 OF 57	2011. 03.08.

IC CARD PROCESS

This model provides most type of IC card compliant to ISO7816 T=0, T=1.

◆ *Processing time* : Less than 1 Sec

◆ *Number and Location of the contacts on IC Card*

: Number and location of the contacts on IC Card is specified in ISO 7816-2 figure 2

Refer to Appendix A.

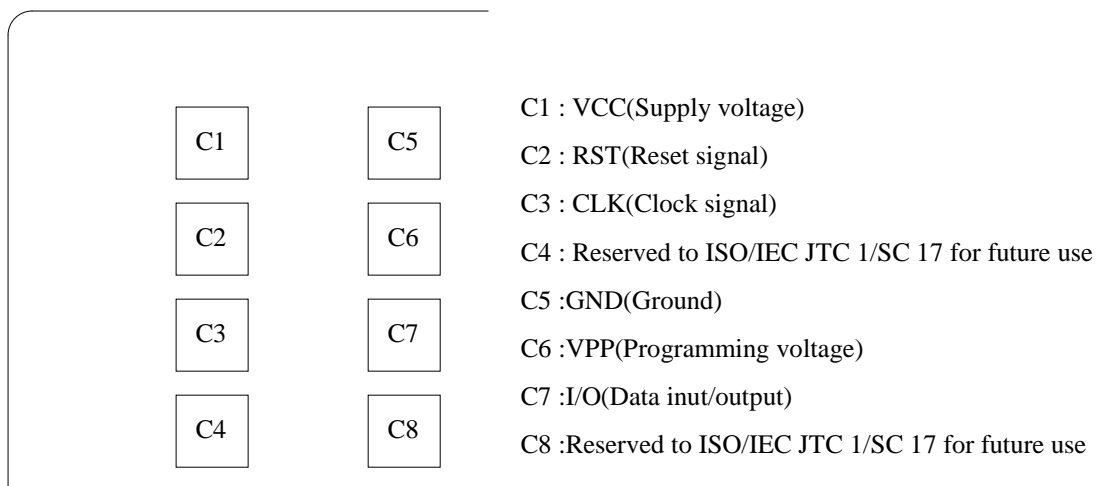

◆ *Power Consumption*

Motor Starting or Reversing : Less than 310mA(50mSec)

Card Feed & Reading : Less than 690mA

Card Feed & Writing : Less than 700mA

Steady state : Less than 180mA

◆ *Life and Reliability*

IC Contact : Approximately 1,000,000 passes

Error Rate : 3/1000 cycle

Doc No	CCM2000 SPECIFICATION	REV	PAGE	DATE
90000130		F	13 OF 57	2011. 03.08.

RF CARD PROCESS

The RF module supports most of RF cards conforming with the ISO14443-3 TypeA(MIFARE Card) with 8 Kbits memory.

◆ *Processing time* : Once Block

Command	Parameter	Time (mSec)		Note
		Type	Max	
Card Read	1 Block	100		Without card moving
Card Write	1 Block	150		Without card moving, With Verify
Card Decrement	1 Block	120		Without card moving
Card Increment	1 Block	120		Without Card moving

◆ *Operating Frequency*

Operating Frequency : 13.56 MHz

Data Transfer Baud : Baud rate 106Kbaud

Doc No	CCM2000 SPECIFICATION	REV	PAGE	DATE
90000130		F	14 OF 57	2011. 03.08.

COMMUNICATION INTERFACE

◆ *Communication Method*

Asynchronous, Half duplex.

Baud Rate : 9600 – 57600Bps , Default : 38400Bps

Start Bit : 1Bit

Data Length : 8Bit

Parity : None

Stop Bit : 1Bit

◆ *Communication Protocol Format*

1 Command Frame Format.

SOH	Null	Length	STX	CMD	DATA	ETX	BCC
1BYTE	1BYTE	2BYTE	1BYTE	3BYTE	N-BYTE	1BYTE	1BYTE

2 Positive Response Frame Format

SOH	Null	Length	STX	CMD	GOOD	0x01	DATA	ETX	BCC
1BYTE	1BYTE	2BYTE	1BYTE	3BYTE	1BYTE	1BYTE	N-BYTE	1BYTE	1BYTE

3 Negative Response Frame Format

SOH	Null	Length	STX	CMD	E-Code	0x00	ETX	BCC
1BYTE	1BYTE	2BYTE	1BYTE	3BYTE	2BYTE	1BYTE	1BYTE	1BYTE

4 BCC (Check Sum)

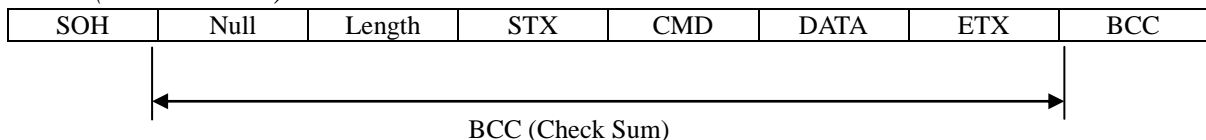

Command Frame BCC = Null ^ Length ^ STX ^ CMD ^ DATA ^ ETX.

Positive Response BCC = Null ^ Length ^ STX ^ CMD ^ GOOD ^ 0x01 ^ DATA ^ ETX.

Negative Response BCC = Null ^ Length ^ STX ^ CMD ^ E-Code ^ ETX.

Doc No	CCM2000 SPECIFICATION	REV	PAGE	DATE
90000130		F	15 OF 57	2011. 03.08.

5. Explanatory note of technical words

Name	Detail
Null	Reserved. Always 0x00.
Length	Data Length from the CMD to DATA.
CMD	Instruction Code (3 Bytes)
GOOD	Normal Execution : 0x0000 (2 Bytes)
E-Code	Command Failed: Refer to "Error Code" (2 Bytes)
BCC	Check Sum.

<Length>, <E-Code>

High Byte	Low Byte
-----------	----------

6. Control Characters

Name	Hex Value	Detail
SOH	0x01	Start of Header
STX	0x02	Start of Text
ETX	0x03	End of Text
ENQ	0x05	Enquiry
ACK	0x06	Positive Acknowledge
NAK	0x15	Negative Acknowledge
CAN	0x18	Cancel

7 COMMUNICATION SEQUENCE / TIMING

7.1 CHARACTER GUIDE TIME

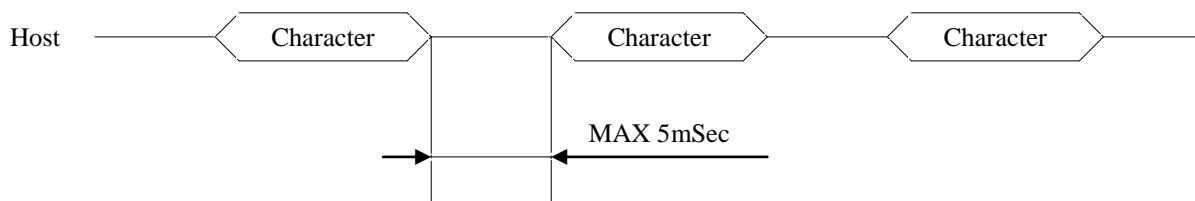

If no consecutive character within 5msec., do time out.

Doc No	CCM2000 SPECIFICATION	REV	PAGE	DATE
90000130		F	16 OF 57	2011. 03.08.

7.2 Command

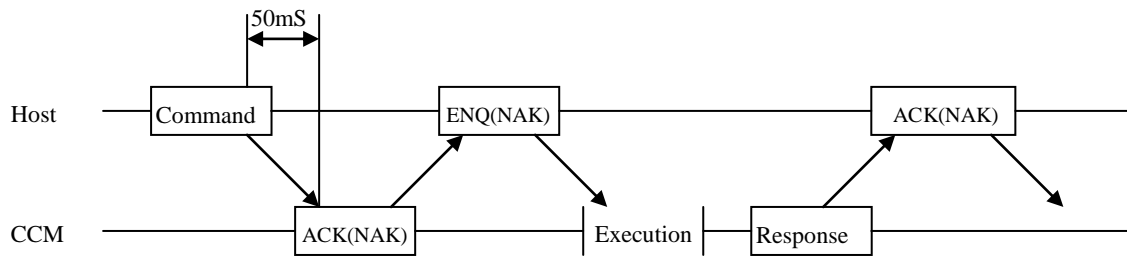

7.3 Inquiry

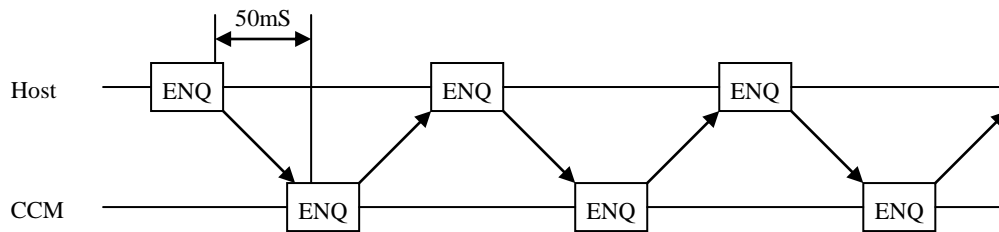

7.4 Sequence

7.4.1 General

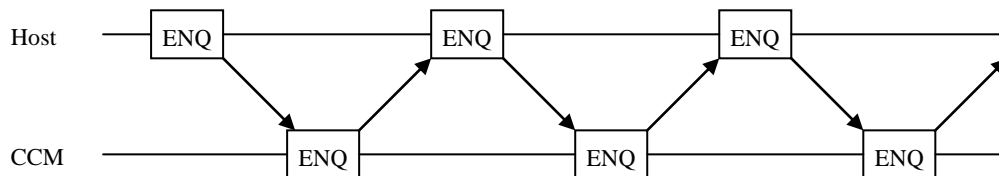
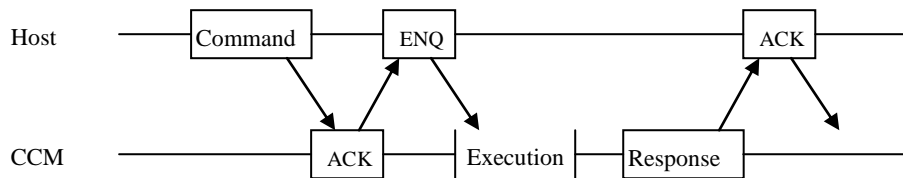

7.4.2 Error1

Doc No	CCM2000 SPECIFICATION	REV	PAGE	DATE
90000130		F	17 OF 57	2011. 03.08.

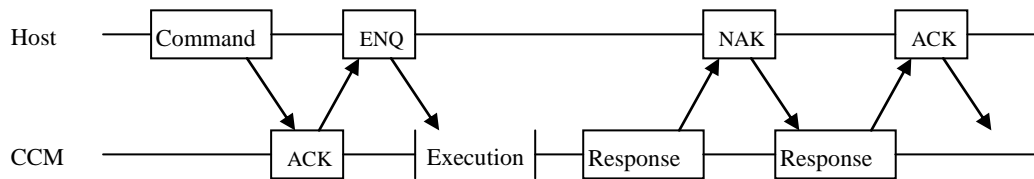
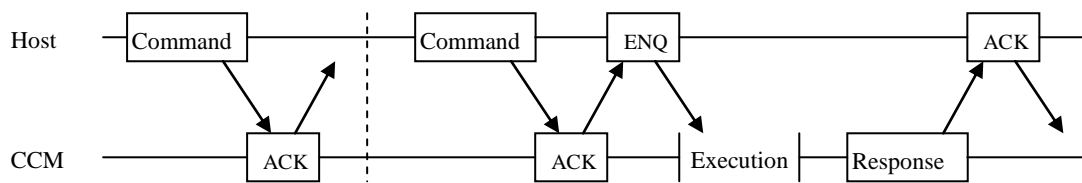
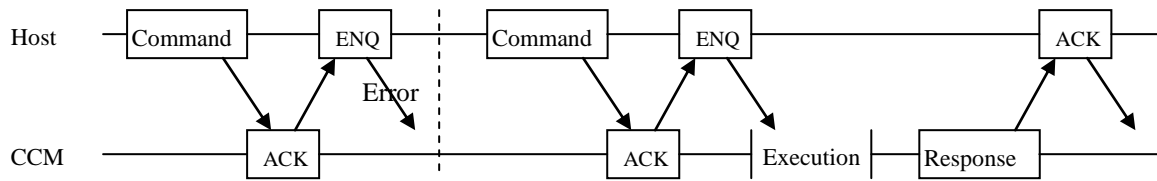
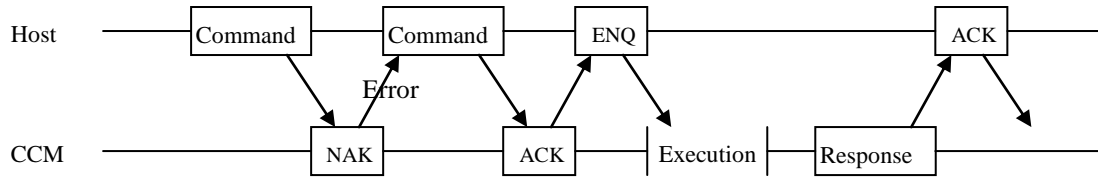
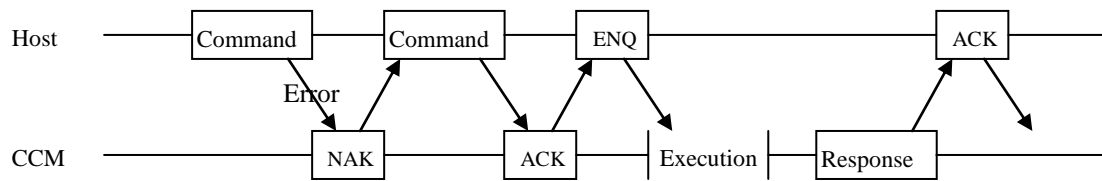
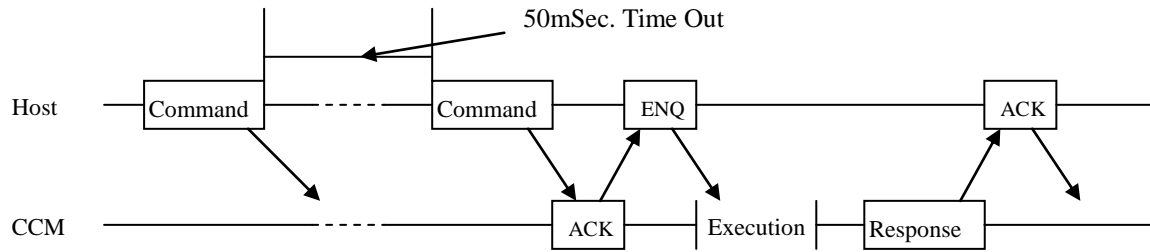

Doc No	CCM2000 SPECIFICATION	REV	PAGE	DATE
90000130		F	18 OF 57	2011. 03.08.

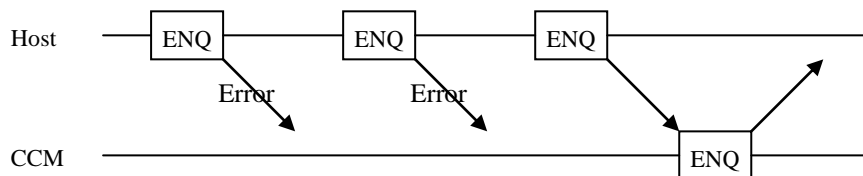
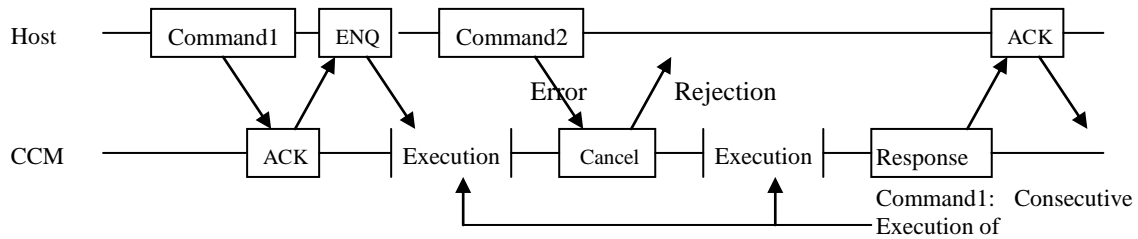
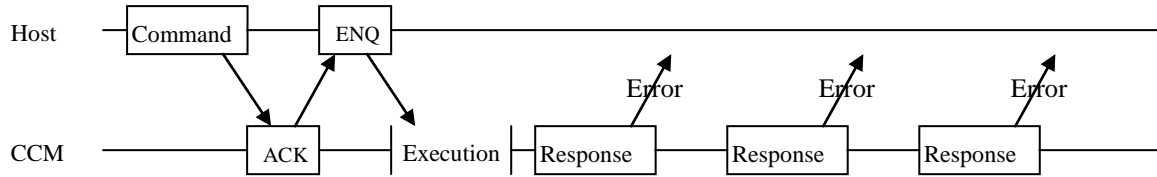
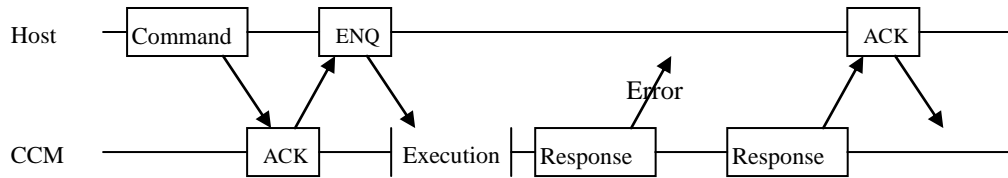
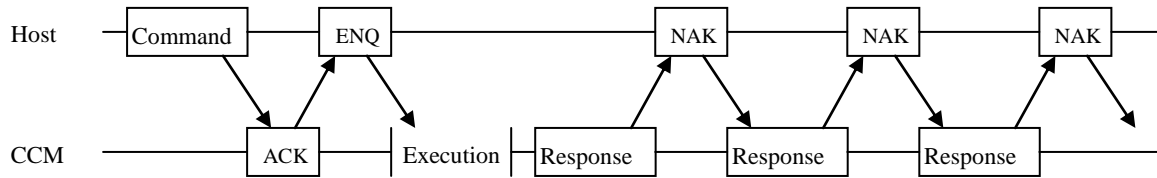
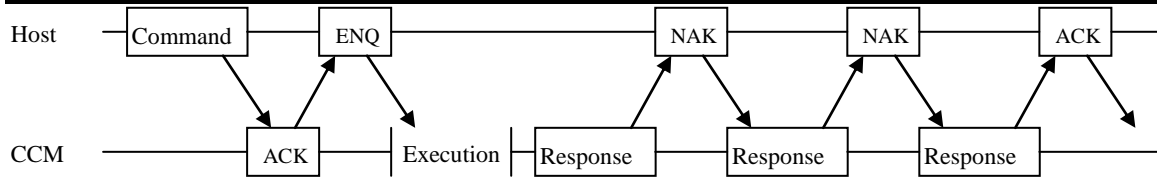

Doc No	CCM2000 SPECIFICATION	REV	PAGE	DATE
90000130		F	19 OF 57	2011. 03.08.

7.4.3 Error2

- When received the NAK packet consecutively.

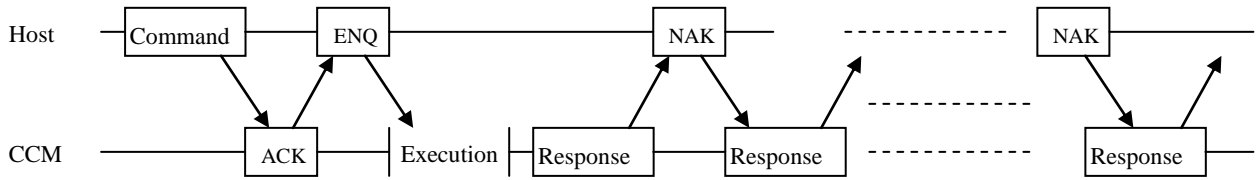

- When the Host sends the command without the ACK packet.

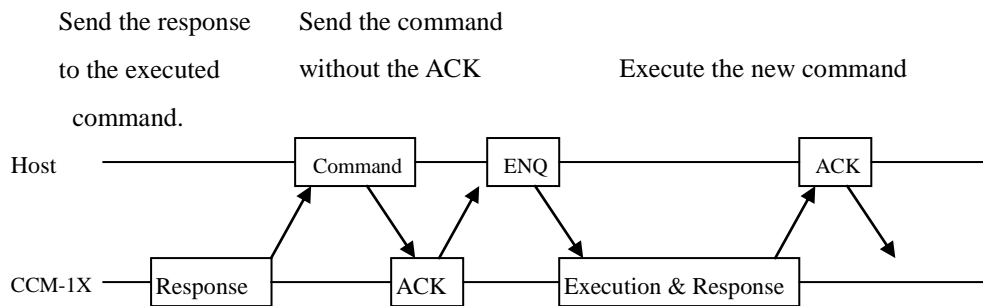

Doc No	CCM2000 SPECIFICATION	REV	PAGE	DATE
90000130		F	20 OF 57	2011. 03.08.

TECHNICAL DRAWING

* *TTL INTERFACE.*

CCM28XXX

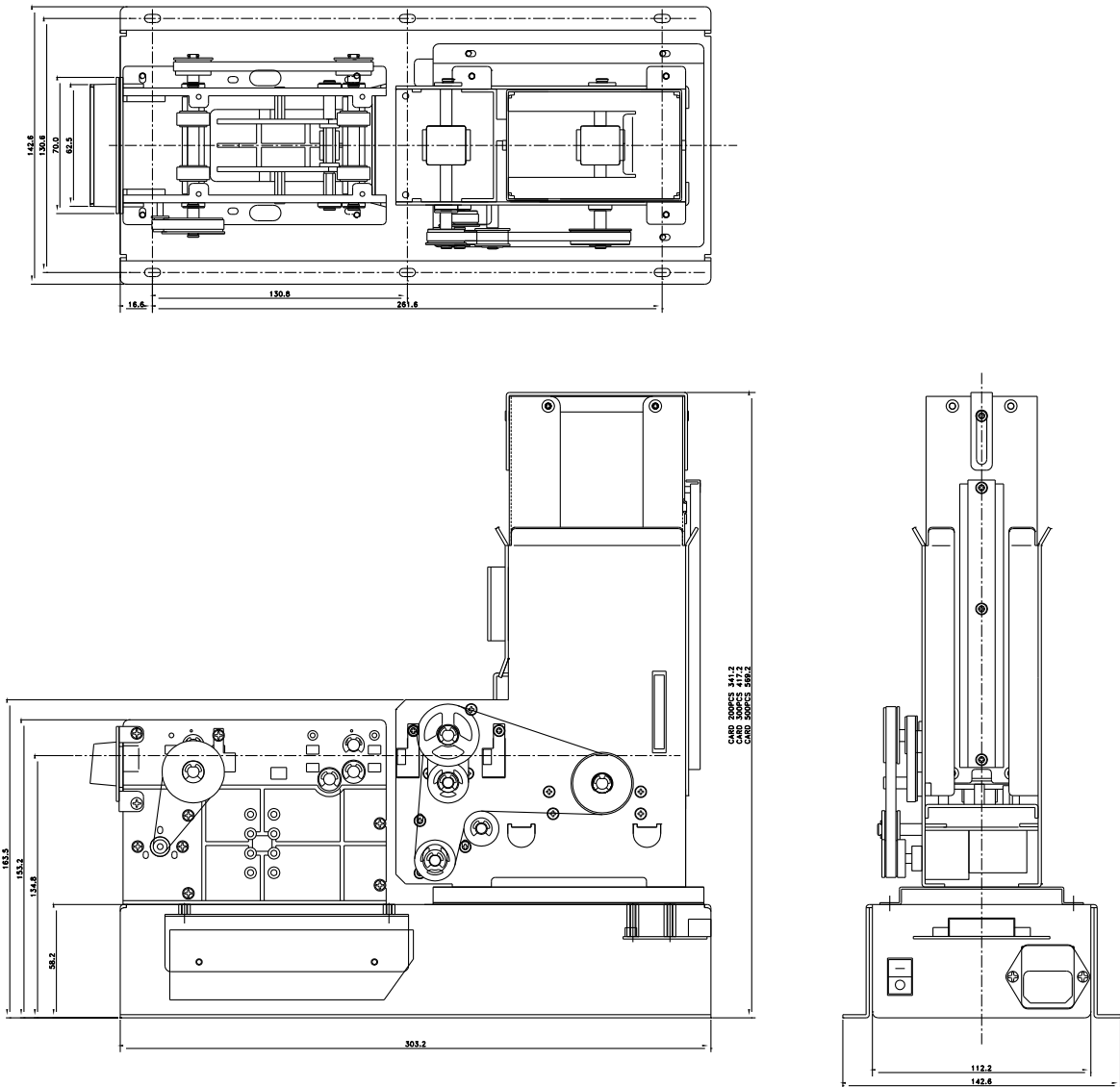

Doc No	CCM2000 SPECIFICATION	REV	PAGE	DATE
90000130		F	21 OF 57	2011. 03.08.

CCM 2XX3X , CCM 2XX4X , CCM 2XX5X

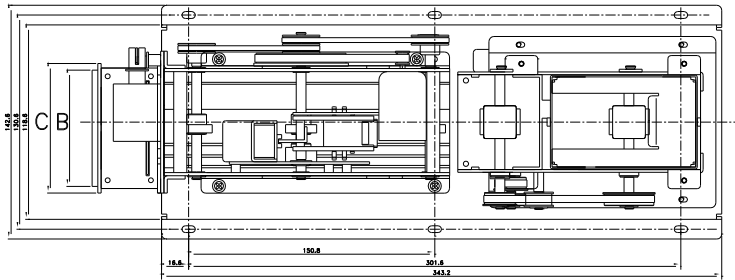

	SHUTTER	SHORT BEZEL
A	44.0mm	16.9mm
B	71.0mm	62.5mm
C	79.0mm	70.0mm

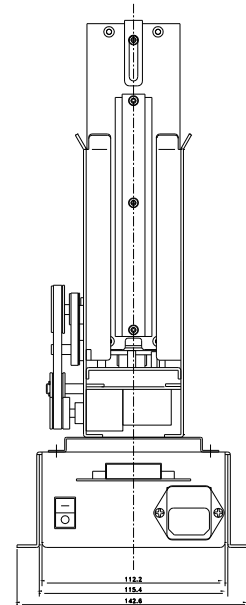
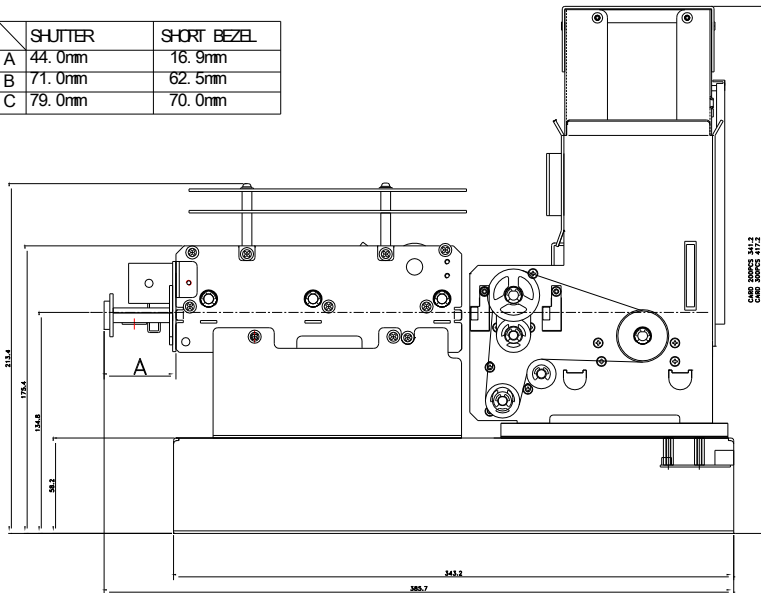

Doc No	CCM2000 SPECIFICATION	REV	PAGE	DATE
90000130		F	22 OF 57	2011. 03.08.

* RS232C INTERFACE.

CCM 2XX3X , CCM 2XX4X , CCM 2XX5X

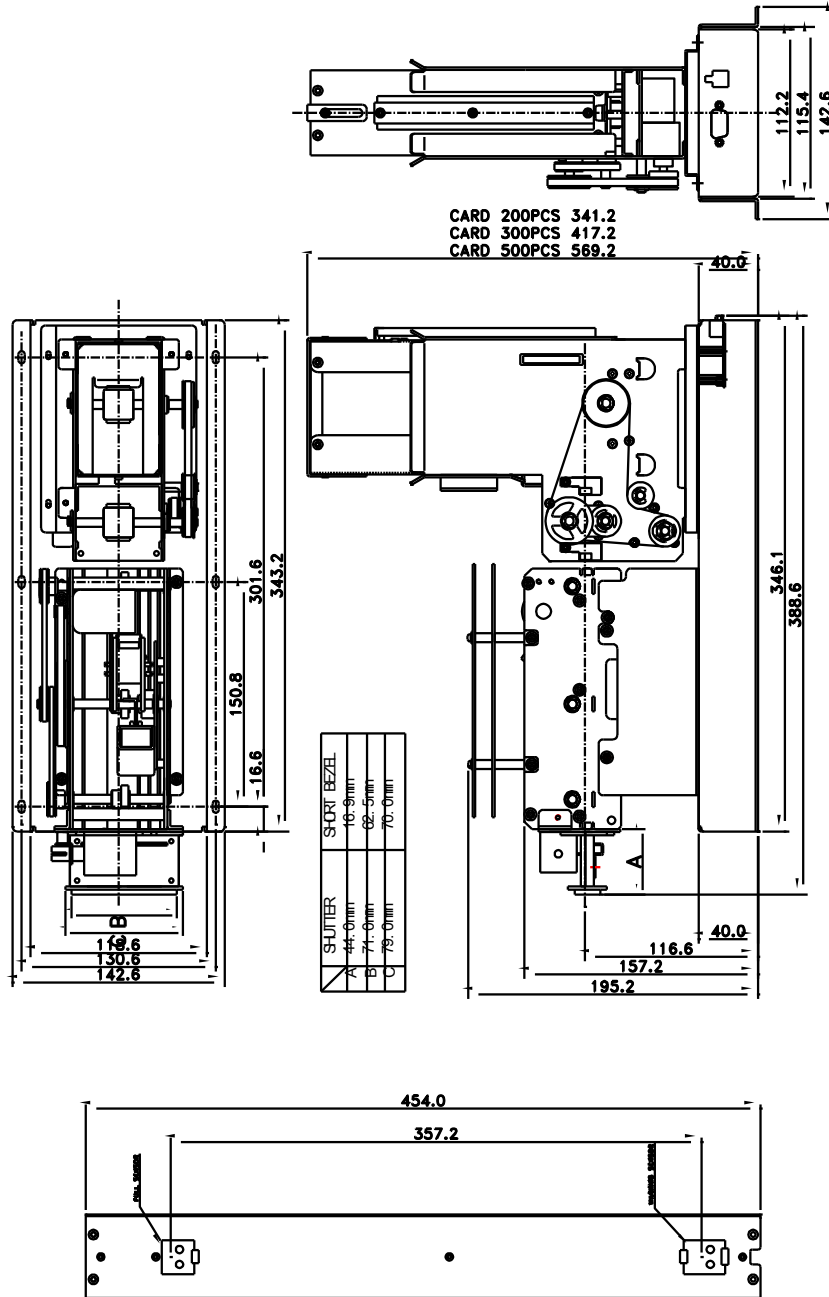

Doc No	CCM2000 SPECIFICATION	REV	PAGE	DATE
90000130		F	23 OF 57	2011. 03.08.

<CCM-2805>

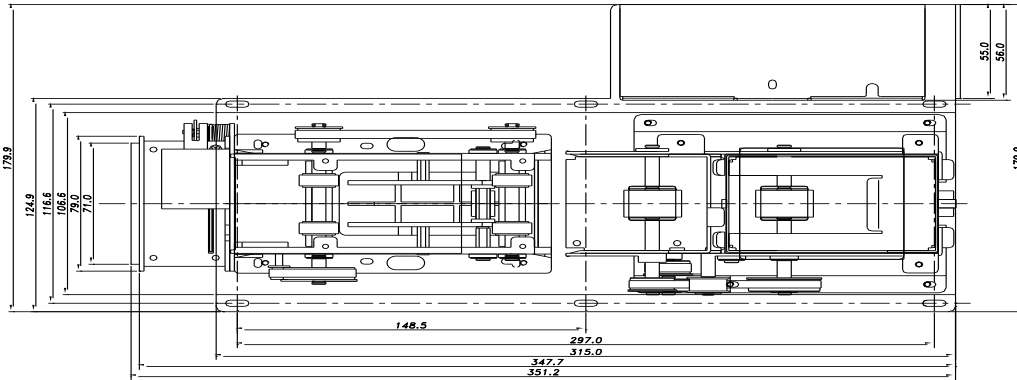

TOP VIEW

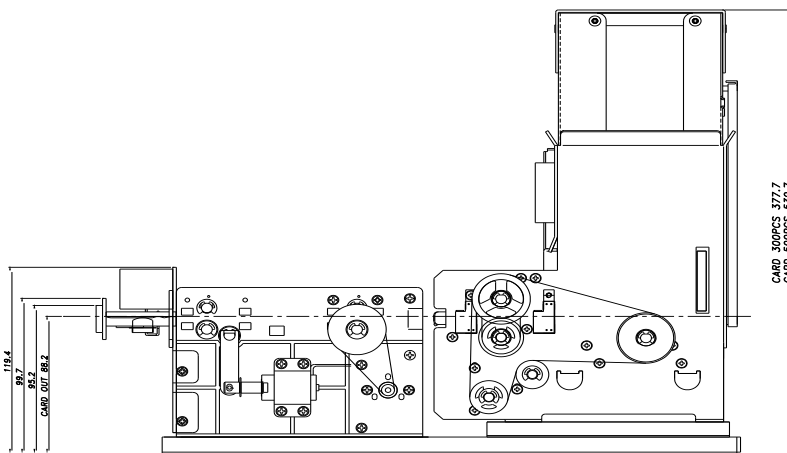

FRONT VIEW

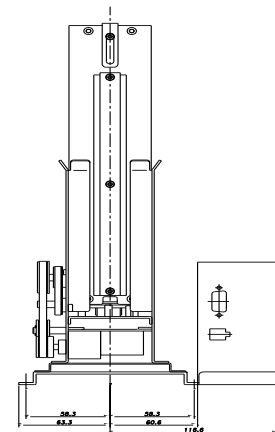

RIGHT VIEW

Doc No	CCM2000 SPECIFICATION	REV	PAGE	DATE
90000130		F	24 OF 57	2011. 03.08.

COMMAND DETAIL

◆ *Command List*

	Item	Cm0	Cm1	Cm2	Detail	Note
COMMON	STATUS	'C'	'1'	'1'	Get Model	
		'C'	'1'	'2'	Get Firmware Version	
		'C'	'1'	'3'	Get Collector	
		'C'	'1'	'6'	Get Card position	
		'C'	'5'	'2'	Get Module Version	
	SETTING	'C'	'2'	'1'	Set RTC IC	Check*
		'C'	'2'	'4'	Set Retry Count	Check*
		'C'	'4'	'0'	Set User Buzz	
	MOVE	'C'	'3'	'2'	Card Move To	
		'C'	'3'	'3'	Card Eject	Forward
'C'		'3'	'9'	Card Collector	Backward	
MAGNETIC CARD	MAGNETIC READ / WRITE	'M'	'3'	'1'	Magnetic Card Read	
		'M'	'3'	'3'	Magnetic Card Write	Verify**
	CLEANING	'M'	'3'	'5'	Magnetic Card All Track Read	
		'M'	'5'	'1'	MSRW Header Cleaning	
IC CARD	IC CONTROL	'I'	'2'	'1'	IC Card Reset	
		'I'	'2'	'2'	IC Card Direct Control	
RF CARD	RF CARD READ / WRITE	'R'	'3'	'1'	RF Card Read in Block Range	
		'R'	'3'	'2'	RF Card Write in Block Range	Verify**
		'R'	'3'	'6'	RF Card Read in Sector Range	
		'R'	'3'	'7'	RF Card Write in Sector Range	
	BALANCE	'R'	'4'	'1'	Balance Increment	
		'R'	'4'	'2'	Balance Decrement	
	SECRET KEY CHANGE	'R'	'5'	'1'	Change 'Secret Key' to other Key	
		'R'	'5'	'2'	Change 'Secret Key' to all the same Key value	
		'R'	'5'	'3'	Select 'Secret Key Index'	
		'R'	'5'	'4'	Change 'RF Card Secret Key' to other Key	
RF DETECT	'R'	'6'	'1'	Check RF card in antenna area		

* Command Check possible with setting the terminal.

** After command execution, verify execution automatically.

Doc No	CCM2000 SPECIFICATION	REV	PAGE	DATE
90000130		F	25 OF 57	2011. 03.08.

◆ *Common*

1 STATUS / SETTING

1.1 “C11” : It is to check out Model number of CCM-2000.

☞ Command Format

SOH	Null	Length	STX	“C11”	ETX	Bcc
-----	------	--------	-----	-------	-----	-----

☞ Positive Response Format

SOH	Null	Length	STX	“C11”	GOOD	‘1’	DATA	ETX	Bcc
-----	------	--------	-----	-------	------	-----	------	-----	-----

☞ Negative Response Format

SOH	Null	Length	STX	“C11”	E-Code	‘0’	ETX	Bcc
-----	------	--------	-----	-------	--------	-----	-----	-----

☞ Response Data Structure

Model No7Byte (ASCII)

1.2 “C12” : It is to check out Firmware Version of CCM-2000

☞ Command Format

SOH	Null	Length	STX	“C12”	ETX	Bcc
-----	------	--------	-----	-------	-----	-----

☞ Positive Response Format

SOH	Null	Length	STX	“C12”	GOOD	‘1’	DATA	ETX	Bcc
-----	------	--------	-----	-------	------	-----	------	-----	-----

☞ Negative Response Format

SOH	Null	Length	STX	“C12”	E-Code	‘0’	ETX	Bcc
-----	------	--------	-----	-------	--------	-----	-----	-----

☞ Response Data Structure

Firmware Version5Byte (ASCII)

1.3 “C13” : It is check out status of Stacker of CCM-2000

☞ Command Format

SOH	Null	Length	STX	“C13”	ETX	Bcc
-----	------	--------	-----	-------	-----	-----

☞ Positive Response Format

SOH	Null	Length	STX	“C13”	GOOD	‘1’	DATA	ETX	Bcc
-----	------	--------	-----	-------	------	-----	------	-----	-----

☞ Negative Response Format

SOH	Null	Length	STX	“C13”	E-Code	‘0’	ETX	Bcc
-----	------	--------	-----	-------	--------	-----	-----	-----

☞ Response Data Structure

Stacker	0x00
1Byte (Hex)	1Byte (Hex)

☞ Data Variable

<Stacker>

Code	Status	Note
0x01	Cartridge Good	
0x02	No Cartridge	
0x04	Cartridge Full	

Doc No	CCM2000 SPECIFICATION	REV	PAGE	DATE
90000130		F	26 OF 57	2011. 03.08.

☞ Note

Stacker Status	Detail
Cartridge Good	Good.
No Cartridge	There is not Cartridge
Cartridge Full	Be filed to capacity in Cartridge.

1.4 “C16” : The card is check by existent location.

☞ Command Format

SOH	Null	Length	STX	“C16”	ETX	Bcc
-----	------	--------	-----	-------	-----	-----

☞ Positive Response Format

SOH	Null	Length	STX	“C16”	GOOD	‘1’	DATA	ETX	Bcc
-----	------	--------	-----	-------	------	-----	------	-----	-----

☞ Negative Response Format

SOH	Null	Length	STX	“C16”	E-Code	‘0’	ETX	Bcc
-----	------	--------	-----	-------	--------	-----	-----	-----

☞ Response Data Structure

Card Position
1Byte (Hex)

☞ Data Variable

<Card Position>

Code	Sensor	Detail
0x01	SEN1	The card is locate NO.1
0x02	SEN2	The card is locate NO.2
0x04	SEN3	The card is locate NO.3
0x08	SEN4	The card is locate NO.4
0x10	SEN5	The card is locate NO.5
0x20	SEN6	The card is locate NO.6
0x40	SEN7	The card is locate NO.7
0x80	SEN8	The card is locate NO.8

Doc No	CCM2000 SPECIFICATION	REV	PAGE	DATE
90000130		F	27 OF 57	2011. 03.08.

<CCM-28XX>

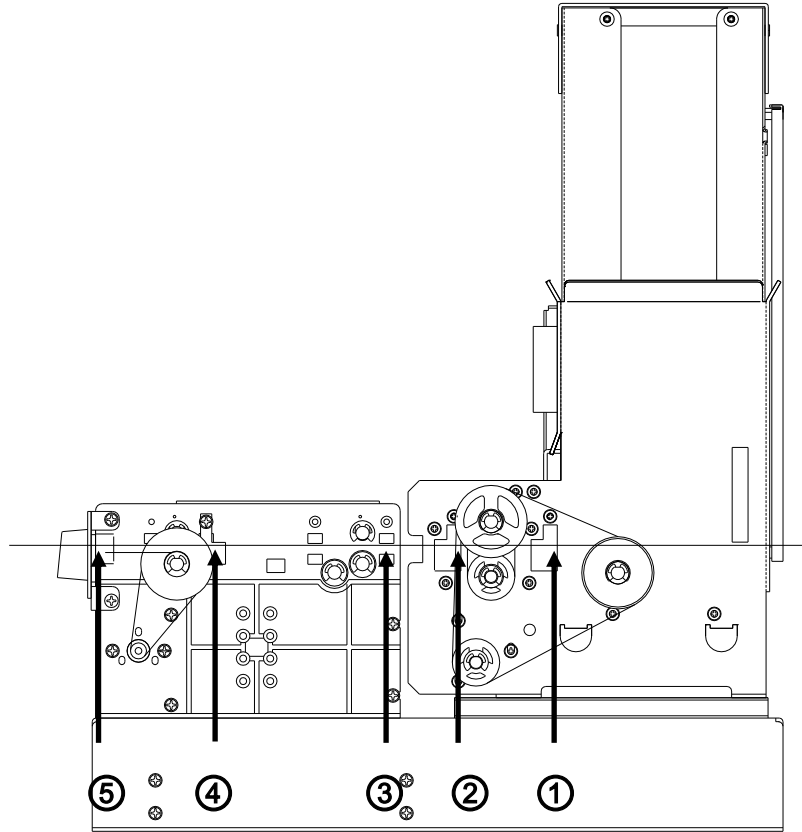

<CCM-24XX>

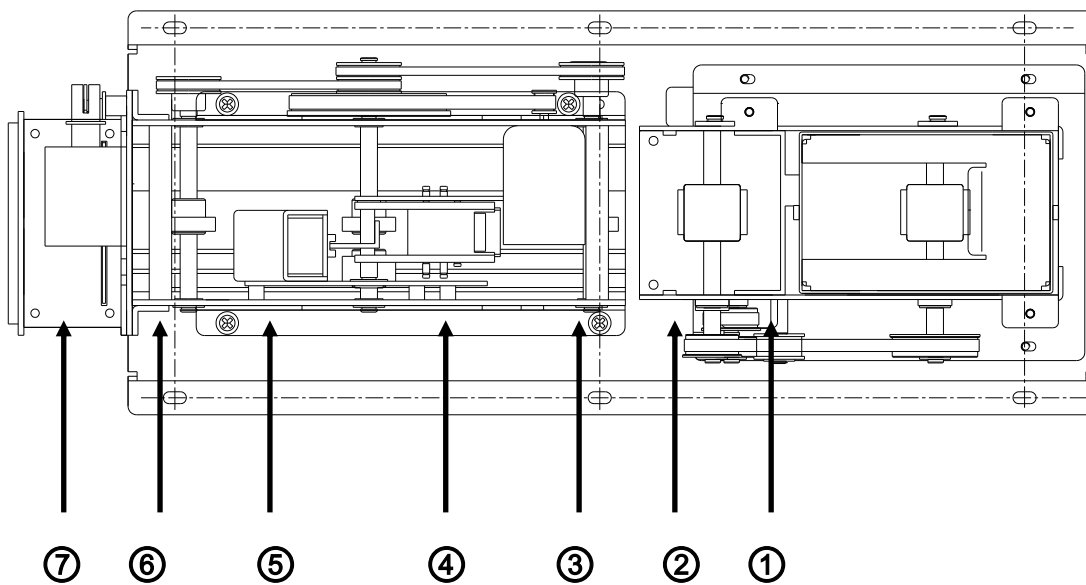

Doc No	CCM2000 SPECIFICATION	REV	PAGE	DATE
90000130		F	28 OF 57	2011. 03.08.

<CCM-2805>

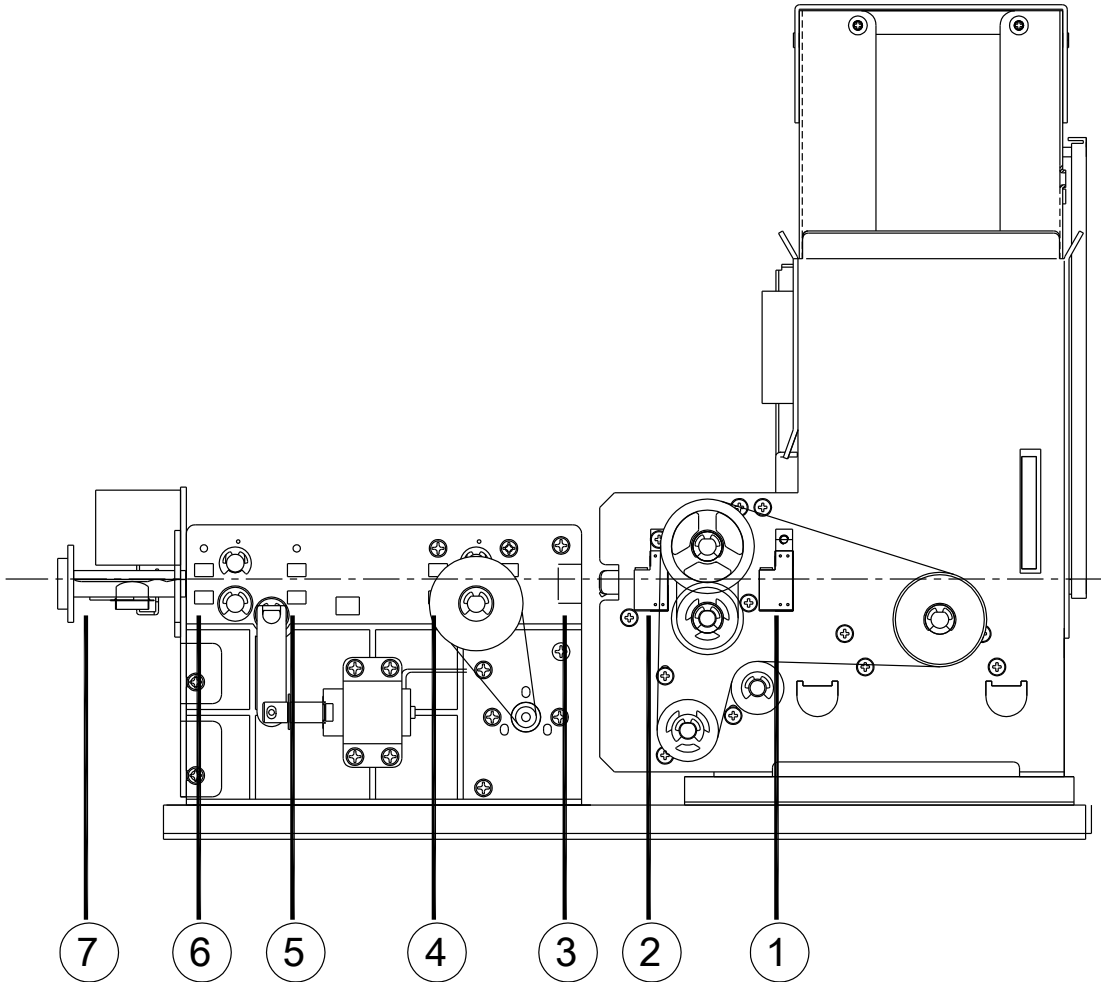

Doc No	CCM2000 SPECIFICATION	REV	PAGE	DATE
90000130		F	29 OF 57	2011. 03.08.

1.5 “C52” : Check out Module Version of CCM-2000.

☞ Command Format

SOH	Null	Length	STX	“C52”	DATA	ETX	Bcc
-----	------	--------	-----	-------	------	-----	-----

☞ Command Data Structure

Module
1Byte (Hex)

☞ Positive Response Format

SOH	Null	Length	STX	“C52”	GOOD	‘1’	DATA	ETX	Bcc
-----	------	--------	-----	-------	------	-----	------	-----	-----

☞ Negative Response Format

SOH	Null	Length	STX	“C52”	E-Code	‘0’	ETX	Bcc
-----	------	--------	-----	-------	--------	-----	-----	-----

☞ Response Data Structure

Version
30 Byte (ASCII)

☞ Data Variable

<Module>

Code	Module	Detail
0x00	“Controller”	Get firmware version of CCM-2000 Main Controller
0x01	“MSRW”	Get firmware version of MSRW(KYT-3000)
0x02	RFU	Reserved

Doc No	CCM2000 SPECIFICATION	REV	PAGE	DATE
90000130		F	30 OF 57	2011. 03.08.

2 SETTING

2.1 “C21” : It is to set or to check ‘RTC IC’.

☞ Command Format

SOH	Null	Length	STX	“C21”	DATA	ETX	Bcc
-----	------	--------	-----	-------	------	-----	-----

☞ Command Data Structure

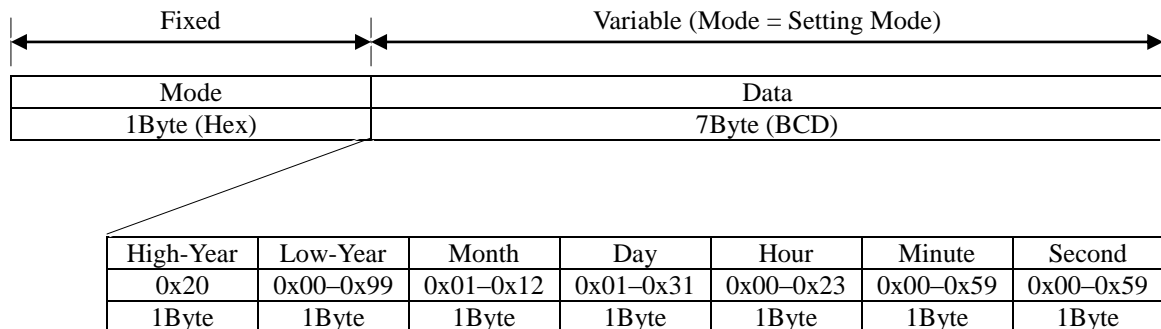

☞ Positive Response Format

SOH	Null	Length	STX	“C21”	GOOD	‘1’	DATA	ETX	Bcc
-----	------	--------	-----	-------	------	-----	------	-----	-----

☞ Negative Response Format

SOH	Null	Length	STX	“C21”	E-Code	‘0’	ETX	Bcc
-----	------	--------	-----	-------	--------	-----	-----	-----

☞ Response Data Structure

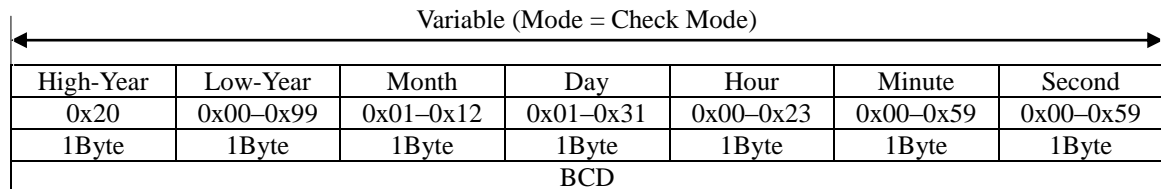

☞ Data Variable

<Mode>

Code	Mode	Detail
0x01	‘Setting Mode’	Set ‘RTC IC’
0x02	‘Check Mode’	Check ‘RTC IC’

☞ Note

‘Day’ is changeable due to the value of ‘Month’.

Doc No	CCM2000 SPECIFICATION	REV	PAGE	DATE
90000130		F	31 OF 57	2011. 03.08.

2.2 “C24” : It is to set or to check ‘Retry Count’.

☞ Command Format

SOH	Null	Length	STX	“C24”	DATA	ETX	Bcc
-----	------	--------	-----	-------	------	-----	-----

☞ Command Data Structure

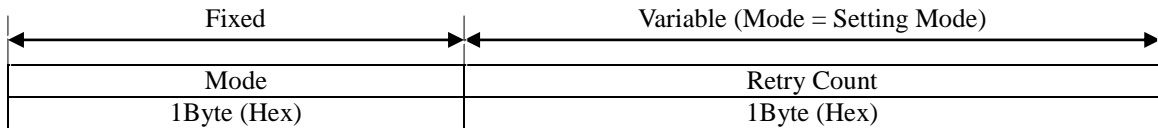

☞ Positive Response Format

SOH	Null	Length	STX	“C24”	GOOD	‘1’	DATA	ETX	Bcc
-----	------	--------	-----	-------	------	-----	------	-----	-----

☞ Negative Response Format

SOH	Null	Length	STX	“C24”	E-Code	‘0’	ETX	Bcc
-----	------	--------	-----	-------	--------	-----	-----	-----

☞ Response Data Structure

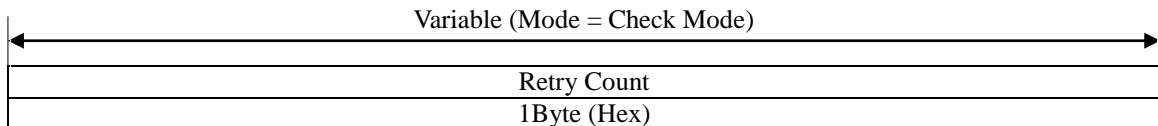

☞ Data Variable

<Mode>

Code	Mode	Detail
0x01	‘Setting Mode’	Set ‘Retry Count’
0x02	‘Check Mode’	Check ‘Retry Count’

<Retry Count>

Code	Setting	Detail	Note
0x00	NON	Do not retry	
0x01	Once	Execute the instruction again.	
0x02	Twice	Retry it twice	
0x03	Three times	Retry it three times	Default

Doc No	CCM2000 SPECIFICATION	REV	PAGE	DATE
90000130		F	32 OF 57	2011. 03.08.

2.3 “C40” : The BUZZ is operate by internal terminal.

☞ Command Format

SOH	Null	Length	STX	“C40”	DATA	ETX	Bcc
-----	------	--------	-----	-------	------	-----	-----

☞ Command Data Structure

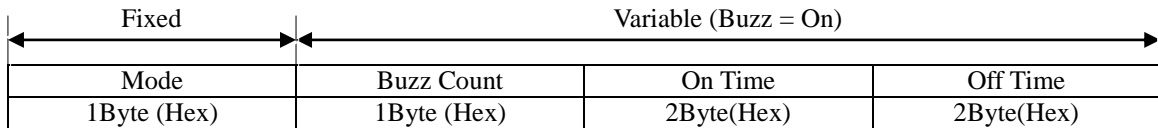

☞ Positive Response Format

SOH	Null	Length	STX	“C40”	GOOD	‘1’	ETX	Bcc
-----	------	--------	-----	-------	------	-----	-----	-----

☞ Negative Response Format

SOH	Null	Length	STX	“C40”	E-Code	‘0’	ETX	Bcc
-----	------	--------	-----	-------	--------	-----	-----	-----

☞ Data Variable

<Mode>

Code	Buzz	Detail
0x01	On	Set Buzz ON
0x02	Off	Set Buzz OFF

<Buzz Count>

Code	Buzz Count	Detail	Note
0x00	Continuous	Buzz continuous occur.	Default
0x01	1	Buzz one time occur.	Note
0x02	2	Buzz two times occur.	Note
---	---	---	---
0x64	100	Buzz hundred times occur.	Note

<On Time/Off Time>

Code	Range	Detail	Note
On Time	100 – 10000	Buzz sound active time	mSec
Off Time	100 – 10000	Buzz sound nonactive time.	mSec

<On Time>, <Off Time>

High Byte	Low Byte
-----------	----------

☞ Note

If set ‘Buzz one time occur’, after the terminal is Buzz one time occur, return to ‘Buzz Off’ state.

Doc No	CCM2000 SPECIFICATION	REV	PAGE	DATE
90000130		F	33 OF 57	2011. 03.08.

3 MOVE

3.1 “C32” : It is take card to Card Reader / Writer Module

☞ Command Format

SOH	Null	Length	STX	“C32”	DATA	ETX	Bcc
-----	------	--------	-----	-------	------	-----	-----

☞ Command Data Structure

Module
1Byte (Hex)

☞ Positive Response Format

SOH	Null	Length	STX	“C32”	GOOD	‘1’	DATA	ETX	Bcc
-----	------	--------	-----	-------	------	-----	------	-----	-----

☞ Negative Response Format

SOH	Null	Length	STX	“C32”	E-Code	‘0’	ETX	Bcc
-----	------	--------	-----	-------	--------	-----	-----	-----

☞ Data Variable

<Module>

Code	Setting	Detail
0x01	MSRW	Card transport to MSRW Module
0x02	IC	Card transport to IC Module
0x03	RF	Card transport to RF Module

3.2 “C33” : It is to dispense out card to the front.

☞ Command Format

SOH	Null	Length	STX	“C33”	ETX	Bcc
-----	------	--------	-----	-------	-----	-----

☞ Positive Response Format

SOH	Null	Length	STX	“C33”	GOOD	‘1’	ETX	Bcc
-----	------	--------	-----	-------	------	-----	-----	-----

☞ Negative Response Format

SOH	Null	Length	STX	“C33”	E-Code	‘0’	ETX	Bcc
-----	------	--------	-----	-------	--------	-----	-----	-----

3.3 “C39” : It is take card to Collector.

☞ Command Format

SOH	Null	Length	STX	“C39”	DATA	ETX	Bcc
-----	------	--------	-----	-------	------	-----	-----

☞ Command Data Structure

Module
1Byte (Hex)[0x01]

☞ Positive Response Format

SOH	Null	Length	STX	“C39”	GOOD	‘1’	DATA	ETX	Bcc
-----	------	--------	-----	-------	------	-----	------	-----	-----

☞ Negative Response Format

SOH	Null	Length	STX	“C39”	E-Code	‘0’	ETX	Bcc
-----	------	--------	-----	-------	--------	-----	-----	-----

Doc No	CCM2000 SPECIFICATION	REV	PAGE	DATE
90000130		F	34 OF 57	2011. 03.08.

◆ *MAGNETIC CARD*

This section describes the commands that can use at the magnetic card.

The data to be written in every track should be conform to the ISO7816-2 standard, the available character is as follows. For more information about Magnetic card, refer to the ISO7816-2 standard.

Track	Available Character Set	Maximum characters	비 고
Track #1	Character, Numbers	76	Except for the special character
Track #2	Numbers	37	
Track #3	Number	104	

The CCM-2000 provides two features for speedy processing. The first is to provide the command combined with ‘Card Move To’ and ‘Magnetic Write’ command.

The second is to lessen the processing time for the ‘magnetic read’ command repeated after latching the data read from card. To latch data occurs at a point of time when verify in the magnetic write command and execute the magnetic read command. However, the latched data is erased when the card is off from the terminal.

Doc No	CCM2000 SPECIFICATION	REV	PAGE	DATE
90000130		F	35 OF 57	2011. 03.08.

Basic Magnetic Card Operations:

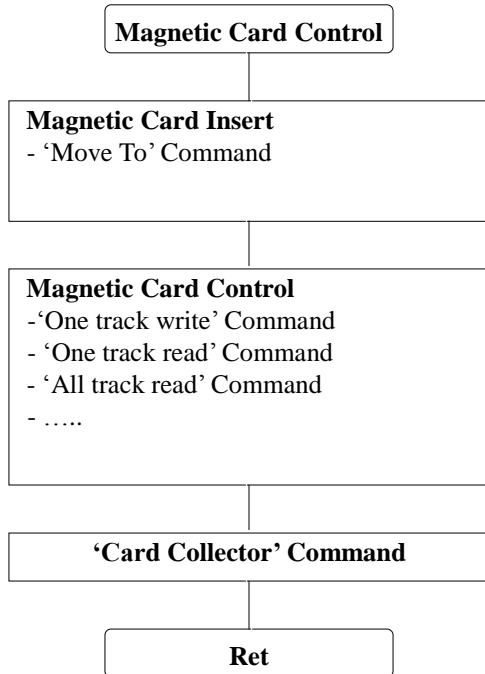

1 MAGNETIC READ / WRITE

1.1 "M31" : It is to read data on track chosen.

☞ Command Format

SOH	Null	Length	STX	"M31"	DATA	ETX	Bcc
-----	------	--------	-----	-------	------	-----	-----

☞ Command Data Structure

Track (1Byte)

☞ Positive Response Format

SOH	Null	Length	STX	"M31"	GOOD	'1'	DATA	ETX	Bcc
-----	------	--------	-----	-------	------	-----	------	-----	-----

☞ Negative Response Format

SOH	Null	Length	STX	"M31"	E-Code	'0'	ETX	Bcc
-----	------	--------	-----	-------	--------	-----	-----	-----

☞ Response Data Structure

Read Data (ASCII Code)

☞ Data Variable

<Track>

Code	Setting	Detail
0x01	Track 1	Read data on Track 1
0x02	Track 2	Read data on Track 2
0x03	Track 3	Read data on Track 3

☞ Note

If the 'Magnetic Read' command is executed normally, the read data is latched.

Doc No	CCM2000 SPECIFICATION	REV	PAGE	DATE
90000130		F	36 OF 57	2011. 03.08.

1.2 “M33” : It is to write data on track chosen.

☞ Command Format

SOH	Null	Length	STX	“M33”	DATA	ETX	Bcc
-----	------	--------	-----	-------	------	-----	-----

☞ Command Data Structure

Track	Write Data
1Byte (Hex)	(ASCII Code)

☞ Positive Response Format

SOH	Null	Length	STX	“M33”	GOOD	‘1’	ETX	Bcc
-----	------	--------	-----	-------	------	-----	-----	-----

☞ Negative Response Format

SOH	Null	Length	STX	“M33”	E-Code	‘0’	ETX	Bcc
-----	------	--------	-----	-------	--------	-----	-----	-----

☞ Data Variable

<Track>

Code	Setting	Detail
0x01	Track 1	Write data to Track 1
0x02	Track 2	Write data to Track 2
0x03	Track 3	Write data to Track 3

☞ Note

If the ‘Magnetic Write’ command is executed normally, the written data is latched. This command has the ‘Verify’ feature.

1.4 “M35” : It is to read data from all three tracks.

☞ Command Format

SOH	Null	Length	STX	“M35”	ETX	Bcc
-----	------	--------	-----	-------	-----	-----

☞ Positive Response Format

SOH	Null	Length	STX	“M35”	GOOD	‘1’	DATA	ETX	Bcc
-----	------	--------	-----	-------	------	-----	------	-----	-----

☞ Negative Response Format

SOH	Null	Length	STX	“M35”	E-Code	‘0’	ETX	Bcc
-----	------	--------	-----	-------	--------	-----	-----	-----

☞ Response Data Structure

0x00	Track1 Data	0x00	Track2 Data	0x00	Track3 Data
1Byte (Hex)	(ASCII)	1Byte (Hex)	(ASCII)	1Byte (Hex)	(ASCII)

☞ Note

If the ‘Magnetic Read’ command is executed normally, the read data is latched.

2 CLEANING

2.1 “M51” : It is to clean Magnetic Head mounted inside MSR.W.

☞ Command Format

SOH	Null	Length	STX	“M51”	ETX	Bcc
-----	------	--------	-----	-------	-----	-----

☞ Positive Response Format

SOH	Null	Length	STX	“M51”	GOOD	‘1’	ETX	Bcc
-----	------	--------	-----	-------	------	-----	-----	-----

☞ Negative Response Format

SOH	Null	Length	STX	“M51”	E-Code	‘0’	ETX	Bcc
-----	------	--------	-----	-------	--------	-----	-----	-----

Doc No	CCM2000 SPECIFICATION	REV	PAGE	DATE
90000130		F	37 OF 57	2011. 03.08.

◆ *IC CARD*

This section describes the commands that can use at the IC card

The IC card should conform to the ISO7816-4 T=0/T=1, these cards is available.

Basic Operating Procedure for the IC card and Memory Card:

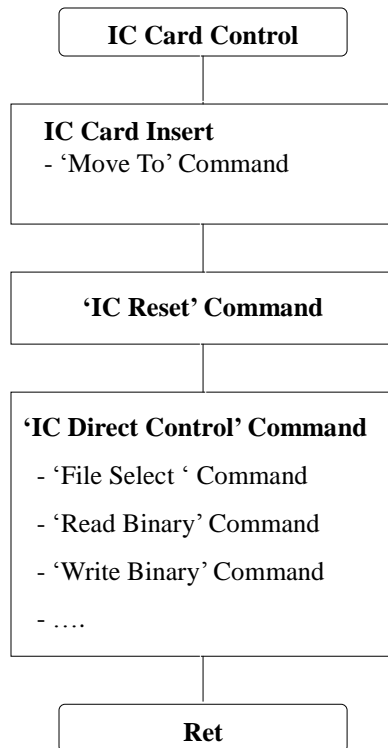

Doc No	CCM2000 SPECIFICATION	REV	PAGE	DATE
90000130		F	38 OF 57	2011. 03.08.

1 IC CONTROL

1.1 "I21" : Reset the IC card and receive the ATR from card.

☞ Command Format

SOH	Null	Length	STX	"I21"	ETX	Bcc
-----	------	--------	-----	-------	-----	-----

☞ Positive Response Format

SOH	Null	Length	STX	"I21"	GOOD	'1'	DATA	ETX	Bcc
-----	------	--------	-----	-------	------	-----	------	-----	-----

☞ Negative Response Format

SOH	Null	Length	STX	"I21"	E-Code	'0'	ETX	Bcc
-----	------	--------	-----	-------	--------	-----	-----	-----

☞ Response Data Structure

Length _ High	Length _ Low	ATR (Answer To Request)
2Byte		N Byte

☞ Example

SAMSUNG SCOS ATR

15 Byte	0x3B	0x6B	0x00	0x00	0x80	0x31	0x80	0x63
	0x53	0x46	0x01	0x83	0x03	0x90	0x00	

1.2 "I22" : Control the card conforming to the ISO 7816 T=0 / T=1, ISO 7816 – 4 standard directly.

☞ Command Format

SOH	Null	Length	STX	"I22"	DATA	ETX	Bcc
-----	------	--------	-----	-------	------	-----	-----

☞ Command Data Structure

Length _ High	Length _ Low	IC Command & IC Data
2Byte		N Byte

☞ Positive Response Format

SOH	Null	Length	STX	"I22"	GOOD	'1'	DATA	ETX	Bcc
-----	------	--------	-----	-------	------	-----	------	-----	-----

☞ Negative Response Format

SOH	Null	Length	STX	"I22"	E-Code	'0'	ETX	Bcc
-----	------	--------	-----	-------	--------	-----	-----	-----

☞ Response Data Structure

Length _ High	Length _ Low	IC Data (or Result)
2Byte		N Byte

Doc No	CCM2000 SPECIFICATION	REV	PAGE	DATE
90000130		F	39 OF 57	2011. 03.08.

☞ IC Command & IC Data Structure

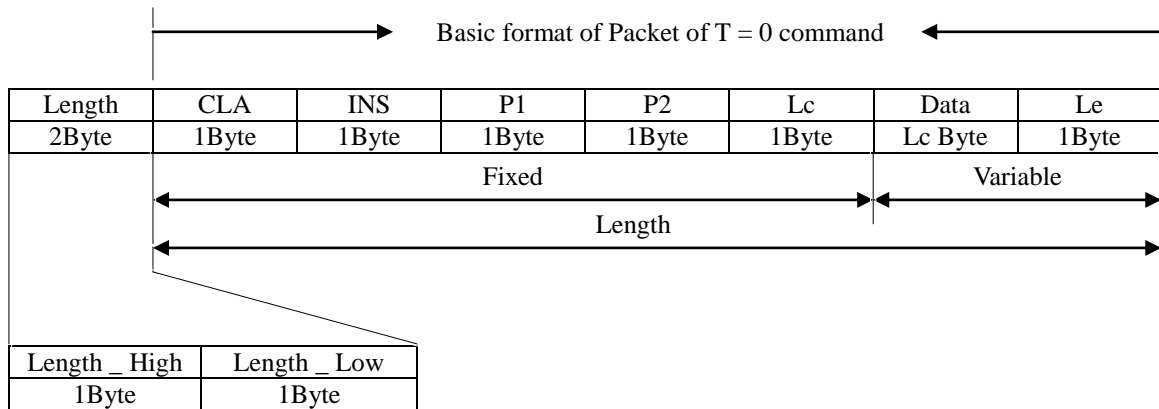

CLA	Class	Note
INS	Instruction	
P1	Offset(High Value)	
P2	Offset(Low Value)	
Lc	A number of data to transfer	Max Value : 255
Data	Data to Transfer	
Le	A number of data to receive	

☞ Format of T = 0 Command

Command	INS Code (Hex Value)
Read Binary Command	B0
Write Binary Command	D0
Update Binary Command	D6
Erase Binary Command	0E
Read Record(s) Command	B2
Write Record Command	D2
Append Record Command	E2
Update Record Command	DC
Get Data Command	CA
Put Data Command	DA
Select File Command	A4
Verify Command	20
Internal Authenticate Command	88
External Authenticate Command	82
Get Challenge Command	84
Manage Channel Command	70

For more information, refer to the ISO 7816 – 4 standard.

Doc No	CCM2000 SPECIFICATION	REV	PAGE	DATE
90000130		F	40 OF 57	2011. 03.08.

☞ Frame Command for SAMSUNG SCOS 3.0

Command	INS Code (Hex Value)
Put Key	EA
Create File	E0
Block	1E
UnBlock	18
Create Session	8A
Set Life Cycle	E8
Forbidden AC	1C
Initialize IEP	50
Load / Cancel IEP	52
Purchase /Unload / Complete IEP	54
Update Parameter	56
Read Balance	5C

Doc No	CCM2000 SPECIFICATION	REV	PAGE	DATE
90000130		F	41 OF 57	2011. 03.08.

◆ *RF CARD*

This section describes the commands that can use at the 'RF CARD'.

The RF Module of his model supports only the MIFARE card.

Item	Cm0	Cm1	Cm2	Detail	Note
RF CARD READ / WRITE	'R'	'3'	'1'	RF Card Read in Block Range	
	'R'	'3'	'2'	RF Card Write in Block Range	Verify
	'R'	'3'	'6'	RF Card Read in Sector Range	
	'R'	'3'	'7'	RF Card Write in Sector Range	
BALANCE	'R'	'4'	'1'	Balance Increment	
	'R'	'4'	'2'	Balance Decrement	
SECRET KEY CHANGE	'R'	'5'	'1'	Change 'Secret Key' to other Key	
	'R'	'5'	'2'	Change 'Secret Key' to all the same Key value	
	'R'	'5'	'3'	Select 'Secret Key Index'	
	'R'	'5'	'4'	Change 'RF Card Secret Key' to other Key	
	'R'	'5'	'5'	Key Set and Change 'Secret Key' to other Key	
	'R'	'5'	'6'	Key Set and Change 'Secret Key' to all the same Key value	
RF DETECT	'R'	'6'	'1'	Check RF card in antenna area	

To use the RF card, you need to initialize at first.

- Setting and updating of the secret key and secret key index.

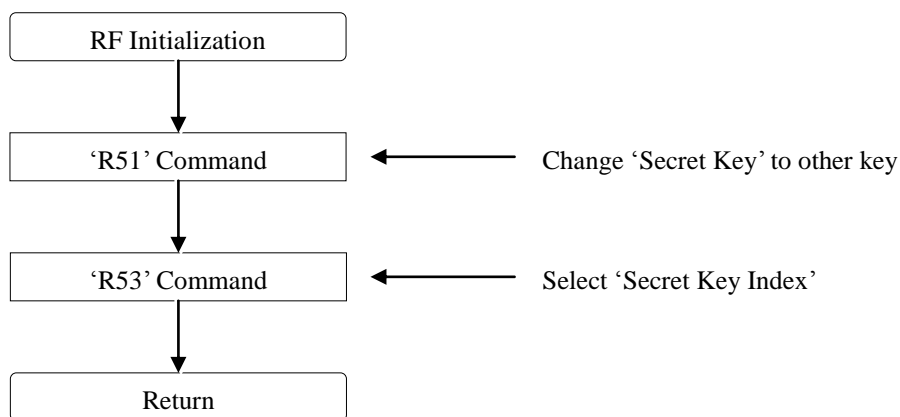

RF Module Initialization

Basic Operating Procedure of the RF card:

Doc No	CCM2000 SPECIFICATION	REV	PAGE	DATE
90000130		F	42 OF 57	2011. 03.08.

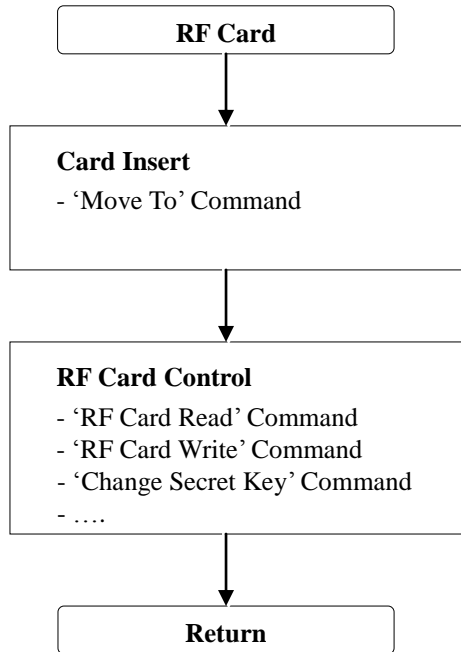

RF Card Basic Operating Procedures

Memory Architecture(map) of the RF card: 1Kbyte

Sector	Block	Size	Detail	Note
Sector 0	Block 0	16Byte	RF Card Information	Can't use
	Block 1	16Byte		
	Block 2	16Byte		
	Block 3	16Byte	'Sector Key'	
Sector 1	Block 0	16Byte	User Available Memory	
	Block 1	16Byte		
	Block 2	16Byte		
	Block 3	16Byte	'Sector Key'	
Sector 2	Block 0	16Byte	User Available Memory	
	Block 1	16Byte		
	Block 2	16Byte		
	Block 3	16Byte	'Sector Key'	
---	---	---	---	---
Sector 15	Block 0	16Byte	User Available Memory	
	Block 1	16Byte		
	Block 2	16Byte		
	Block 3	16Byte	'Sector Key'	

Doc No	CCM2000 SPECIFICATION	REV	PAGE	DATE
90000130		F	43 OF 57	2011. 03.08.

Memory Architecture(map) of the RF card: 4Kbyte.

Sector	Block	Size	Detail	Note
Sector 0	Block 0	16Byte	RF Card Information	Can't use
	Block 1	16Byte		
	Block 2	16Byte		
	Block 3	16Byte	'Sector Key'	
Sector 1	Block 0	16Byte	User Available Memory	
	Block 1	16Byte		
	Block 2	16Byte		
	Block 3	16Byte	'Sector Key'	
Sector 2	Block 0	16Byte	User Available Memory	
	Block 1	16Byte		
	Block 2	16Byte		
	Block 3	16Byte	'Sector Key'	
---	---	---	---	---
Sector 31	Block 0	16Byte	User Available Memory	
	Block 1	16Byte		
	Block 2	16Byte		
	Block 3	16Byte	'Sector Key'	
Sector 32	Block 0	16Byte	User Available Memory	
	Block 1	16Byte		
	Block 2	16Byte		
	Block 3	16Byte		
	Block 4	16Byte		
	---	---		
	Block 13	16Byte		
	Block 14	16Byte		
Block 15	16Byte	'Sector Key'	Can't use	
---	---	---	---	---
Sector 39	Block 0	16Byte	User Available Memory	
	Block 1	16Byte		
	Block 2	16Byte		
	Block 3	16Byte		
	Block 4	16Byte		
	---	---		
	Block 13	16Byte		
	Block 14	16Byte		
Block 15	16Byte	'Sector Key'	Can't use	

Doc No	CCM2000 SPECIFICATION	REV	PAGE	DATE
90000130		F	44 OF 57	2011. 03.08.

1 RF CARD READ / WRITE

1.1 "R31" : Read RF card data & Secret Key in block range

☞ Command Format

SOH	Null	Length	STX	"R31"	DATA	ETX	Bcc
-----	------	--------	-----	-------	------	-----	-----

☞ Command Data Structure

Sector	Block
0x00-0x0f or 0x00-0x27	0x00- 0x03 or 0x00-0x15
1Byte (Hex)	1Byte (Hex)

☞ Positive Response Format

SOH	Null	Length	STX	"R31"	GOOD	'1'	DATA	ETX	Bcc
-----	------	--------	-----	-------	------	-----	------	-----	-----

☞ Negative Response Format

SOH	Null	Length	STX	"R31"	E-Code	'0'	ETX	Bcc
-----	------	--------	-----	-------	--------	-----	-----	-----

☞ Response Data Structure

Sector	Block	Read Data
1Byte (Hex)	1Byte (Hex)	16 Byte (Hex)

D0	D1	D2	---	D14	D15
1Byte	1Byte	1Byte	---	1Byte	1Byte

☞ Note

1K can use the sector 0 to 15 contain 3blocks for storing data.

4K can use the sector 0 to 31 contain 3blocks and sector 32 to 39 contain 15 blocks for storing data.

1.2 "R32" : Write RF card data in block range

☞ Command Format

SOH	Null	Length	STX	"R32"	DATA	ETX	Bcc
-----	------	--------	-----	-------	------	-----	-----

☞ Command Data Structure

Sector	Block	Write Data
0x00-0x0f or 0x00-0x27	0x00- 0x02 or 0x00-0x14	0x00 – 0xff
1Byte (Hex)	1Byte (Hex)	16Byte (Hex)

D0	D1	D2	---	D14	D15
1Byte	1Byte	1Byte	---	1Byte	1Byte

☞ Positive Response Format

SOH	Null	Length	STX	"R32"	GOOD	'1'	ETX	Bcc
-----	------	--------	-----	-------	------	-----	-----	-----

☞ Negative Response Format

SOH	Null	Length	STX	"R32"	E-Code	'0'	ETX	Bcc
-----	------	--------	-----	-------	--------	-----	-----	-----

☞ Note

1K can use the sector 0 to 15 contain 3blocks for storing data.

4K can use the sector 0 to 31 contain 3blocks and sector 32 to 39 contain 15 blocks for storing data.

Doc No	CCM2000 SPECIFICATION	REV	PAGE	DATE
90000130		F	45 OF 57	2011. 03.08.

1.3 “R36” : Read RF card data in sector range

☞ Command Format

SOH	Null	Length	STX	“R36”	DATA	ETX	Bcc
-----	------	--------	-----	-------	------	-----	-----

☞ Command Data Structure

Sector
0x00 – 0x0f or 0x00 – 0x27
1Byte (Hex)

☞ Positive Response Format

SOH	Null	Length	STX	“R36”	GOOD	‘1’	DATA	ETX	Bcc
-----	------	--------	-----	-------	------	-----	------	-----	-----

☞ Negative Response Format

SOH	Null	Length	STX	“R36”	E-Code	‘0’	ETX	Bcc
-----	------	--------	-----	-------	--------	-----	-----	-----

☞ Response Data Structure

0x00	Read Data (0)	0x01	Read Data (1)	0x02	Read Data (2)
1Byte (Hex)	16Byte (Hex)	1Byte (Hex)	16Byte (Hex)	1Byte (Hex)	16Byte (Hex)

D0	D1	D2	---	D14	D15
1Byte	1Byte	1Byte	---	1Byte	1Byte

☞ Note

1K can use the sector 0 to 15 contain 3blocks for storing data.

4K can use the sector 0 to 31 contain 3blocks and sector 32 to 39 contain 15 blocks for storing data.

1.4 “R37” : Write RF card data in sector range (except Sector 0)

☞ Command Format

SOH	Null	Length	STX	“R37”	DATA	ETX	Bcc
-----	------	--------	-----	-------	------	-----	-----

☞ Command Data Structure

Sector	Write Data
0x00 – 0x0f or 0x00 – 0x27	0x00 – 0xff
1Byte (Hex)	51Byte (Hex)

0x00	Read Data (0)	0x01	Read Data (1)	0x02	Read Data (2)
1Byte (Hex)	16Byte (Hex)	1Byte (Hex)	16Byte (Hex)	1Byte (Hex)	16Byte (Hex)

D0	D1	D2	---	D14	D15
1Byte	1Byte	1Byte	---	1Byte	1Byte

☞ Positive Response Format

SOH	Null	Length	STX	“R37”	GOOD	‘1’	ETX	Bcc
-----	------	--------	-----	-------	------	-----	-----	-----

☞ Negative Response Format

SOH	Null	Length	STX	“R37”	E-Code	‘0’	ETX	Bcc
-----	------	--------	-----	-------	--------	-----	-----	-----

☞ Note

1K can use the sector 0 to 15 contain 3blocks for storing data.

4K can use the sector 0 to 31 contain 3blocks and sector 32 to 39 contain 15 blocks for storing data.

Doc No	CCM2000 SPECIFICATION	REV	PAGE	DATE
90000130		F	46 OF 57	2011. 03.08.

2 BALANCE

2.1 “R41” : Increment the balance of card to the specified amount.

☞ Command Format

SOH	Null	Length	STX	“R41”	DATA	ETX	Bcc
-----	------	--------	-----	-------	------	-----	-----

☞ Command Data Structure

Sector	Block	Index Value
0x00-0x0f or 0x00-0x27	0x00- 0x02 or 0x00-0x14	0x00000000 – 0xffffffff
1Byte (Hex)	1Byte (Hex)	4Byte (Hex)

V0	V1	V2	V3
0x00-0xff	0x00-0xff	0x00-0xff	0x00-0xff
1Byte(Hex, LSB)	1Byte(Hex)	1Byte(Hex)	1Byte(Hex, MSB)

☞ Positive Response Format

SOH	Null	Length	STX	“R41”	GOOD	‘1’	ETX	Bcc
-----	------	--------	-----	-------	------	-----	-----	-----

☞ Negative Response Format

SOH	Null	Length	STX	“R41”	E-Code	‘0’	ETX	Bcc
-----	------	--------	-----	-------	--------	-----	-----	-----

☞ Note

The balance should be written in the Electronic Purse format in the card.

1K can use the sector 0 to 15 contain 3blocks for storing data.

4K can use the sector 0 to 31 contain 3blocks and sector 32 to 39 contain 15 blocks for storing data.

2.1 “R42” : Decrement the balance of card to the specified amount..

☞ Command Format

SOH	Null	Length	STX	“R42”	DATA	ETX	Bcc
-----	------	--------	-----	-------	------	-----	-----

☞ Command Data Structure

Sector	Block	Index Value
0x00-0x0f or 0x00-0x27	0x00- 0x02 or 0x00-0x14	0x00000000 – 0xffffffff
1Byte (Hex)	1Byte (Hex)	4Byte (Hex)

V0	V1	V2	V3
0x00-0xff	0x00-0xff	0x00-0xff	0x00-0xff
1Byte(Hex, LSB)	1Byte(Hex)	1Byte(Hex)	1Byte(Hex, MSB)

☞ Positive Response Format

SOH	Null	Length	STX	“R42”	GOOD	‘1’	ETX	Bcc
-----	------	--------	-----	-------	------	-----	-----	-----

☞ Negative Response Format

SOH	Null	Length	STX	“R42”	E-Code	‘0’	ETX	Bcc
-----	------	--------	-----	-------	--------	-----	-----	-----

☞ Note

The balance should be written in the Electronic Purse format in the card.

1K can use the sector 0 to 15 contain 3blocks for storing data.

4K can use the sector 0 to 31 contain 3blocks and sector 32 to 39 contain 15 blocks for storing data.

Doc No	CCM2000 SPECIFICATION	REV	PAGE	DATE
90000130		F	47 OF 57	2011. 03.08.

3 SECRET KEY

3.1 "R51" : Change 'Secret Key' to a new key

☞ Command Format

SOH	Null	Length	STX	"R51"	DATA	ETX	Bcc
-----	------	--------	-----	-------	------	-----	-----

☞ Command Data Structure

Sector	KEY A	KEY B
0x00 – 0x0f or 0x00 – 0x27	0x00 – 0xff	0x00 – 0xff
1Byte (Hex)	6Byte (Hex)	6Byte (Hex)

☞ Positive Response Format

SOH	Null	Length	STX	"R51"	GOOD	'1'	ETX	Bcc
-----	------	--------	-----	-------	------	-----	-----	-----

☞ Negative Response Format

SOH	Null	Length	STX	"R51"	E-Code	'0'	ETX	Bcc
-----	------	--------	-----	-------	--------	-----	-----	-----

☞ Note

CCM-2000 Series 'Secret Key' Default – Key Set 0

KEY A : FFFFFFFFFF

KEY B : FFFFFFFFFF

1K can use the sector 0 to 15 contain 3blocks for storing data.

4K can use the sector 0 to 31 contain 3blocks and sector 32 to 39 contain 15 blocks for storing data.

3.2 "R52" : Change 'Secret Key' to all the same key value

☞ Command Format

SOH	Null	Length	STX	"R52"	DATA	ETX	Bcc
-----	------	--------	-----	-------	------	-----	-----

☞ Command Data Structure

KEY A	KEY B
0x00 – 0xff	0x00 – 0xff
6Byte (Hex)	6Byte (Hex)

☞ Positive Response Format

SOH	Null	Length	STX	"R52"	GOOD	'1'	ETX	Bcc
-----	------	--------	-----	-------	------	-----	-----	-----

☞ Negative Response Format

SOH	Null	Length	STX	"R52"	E-Code	'0'	ETX	Bcc
-----	------	--------	-----	-------	--------	-----	-----	-----

☞ Note

CCM-2000 Series 'Secret Key' Default – Key Set 0

KEY A : FFFFFFFFFF

KEY B : FFFFFFFFFF

Doc No	CCM2000 SPECIFICATION	REV	PAGE	DATE
90000130		F	48 OF 57	2011. 03.08.

3.3 “R53” : Select ‘Secret Key Index’

☞ Command Format

SOH	Null	Length	STX	“R53”	DATA	ETX	Bcc
-----	------	--------	-----	-------	------	-----	-----

☞ Command Data Structure

Index
0x01 – 0x02
1Byte (Hex)

☞ Positive Response Format

SOH	Null	Length	STX	“R53”	GOOD	‘1’	ETX	Bcc
-----	------	--------	-----	-------	------	-----	-----	-----

☞ Negative Response Format

SOH	Null	Length	STX	“R53”	E-Code	‘0’	ETX	Bcc
-----	------	--------	-----	-------	--------	-----	-----	-----

☞ Data Variable

<Index>

Code	Setting	Detail
0x01	KEY A	Select ‘Secret Key A’
0x02	KEY B	Select ‘Secret Key B’

☞ Note

CCM-2000 Series ‘Secret Key Index’ Default

‘Secret Key Index ‘ : KEY A

3.4 “R54” : Change RF card ‘Secret Key’ to other key

☞ Command Format

SOH	Null	Length	STX	“R54”	DATA	ETX	Bcc
-----	------	--------	-----	-------	------	-----	-----

☞ Command Data Structure

Sector	KEY A	Access	KEY B
0x00 – 0x0f or 0x00 – 0x27	0x00 – 0xff	0x00 – 0xff	0x00 – 0xff
1Byte (Hex)	6Byte (Hex)	4Byte (Hex)	6Byte (Hex)

☞ Positive Response Format

SOH	Null	Length	STX	“R54”	GOOD	‘1’	ETX	Bcc
-----	------	--------	-----	-------	------	-----	-----	-----

☞ Negative Response Format

SOH	Null	Length	STX	“R54”	E-Code	‘0’	ETX	Bcc
-----	------	--------	-----	-------	--------	-----	-----	-----

☞ Warning

If you use this command incorrectly, it couldn’t be authenticated from the card.

1K can use the sector 0 to 15 contain 3blocks for storing data.

4K can use the sector 0 to 31 contain 3blocks and sector 32 to 39 contain 15 blocks for storing data.

Doc No	CCM2000 SPECIFICATION	REV	PAGE	DATE
90000130		F	49 OF 57	2011. 03.08.

4 RF DETECT

4.1 "R61" : RF card detect in antenna area

☞ Command Format

SOH	Null	Length	STX	"R61"	ETX	Bcc
-----	------	--------	-----	-------	-----	-----

☞ Positive Response Format

SOH	Null	Length	STX	"R61"	GOOD	DATA	'1'	ETX	Bcc
-----	------	--------	-----	-------	------	------	-----	-----	-----

☞ Negative Response Format

SOH	Null	Length	STX	"R61"	E-Code	'0'	ETX	Bcc
-----	------	--------	-----	-------	--------	-----	-----	-----

☞ Response Data Structure

Serial Number
Hex Code
4Byte

☞ Note

If the RF card is detected, this command send the serial number to host. But, it doesn't authenticate the Secret Key of the RF card.

Doc No	CCM2000 SPECIFICATION	REV	PAGE	DATE
90000130		F	50 OF 57	2011. 03.08.

◆ **CCM2006 TTL INTERFACE.**

. Input power : AC 110 ~ AC 220V Free voltage.

. Interface connector : Part number : HIF3F-20PA-2.54DS

. Connector number : J4

. Connector signal table

No	Signal Name	Input/Output	Function	Configuration
1	FEED_MOTOR_ENA	INPUT	-	
2	COLLECTOR MOTOR_ENA	INPUT	-	-
3	FEED_MOTOR_A	INPUT	-	-
4	COLLECTOR MOTOR_A	INPUT	-	-
5	FEED_MOTOR_B	INPUT	-	-
6	COLLECTOR MOTOR_B	INPUT	-	-
7	RFU	-	-	-
8	COLL_SENSOR_FRONT	OUTPUT	Detected by sensor	Active High
9	FEED_SEN1	OUTPUT	Detected by sensor	Active High
10	COLL_SENSOR_END	OUTPUT	Detected by sensor	Active High
11	GND(Common)	-	-	-
12	GND(Common)	-	-	-
13	FEED_SEN2	OUTPUT	Detected by sensor	Active High
14	RFU	-	-	Active High
15	FEED_SEN3	OUTPUT	Detected by sensor	Active High
16	COLL_SENSOR_FULL	OUTPUT	Detected by sensor	Active Low
17	RFU	-	-	-
18	COLL_SENSOR_CONTACT	OUTPUT	Detected by sensor	Active High
19	RFU	-	-	-
20	RFU	-	-	-



Power S/W

TTL Connector

AC Socket

Doc No	CCM2000 SPECIFICATION	REV	PAGE	DATE
90000130		F	51 OF 57	2011. 03.08.

. TTL Connector Pin Number

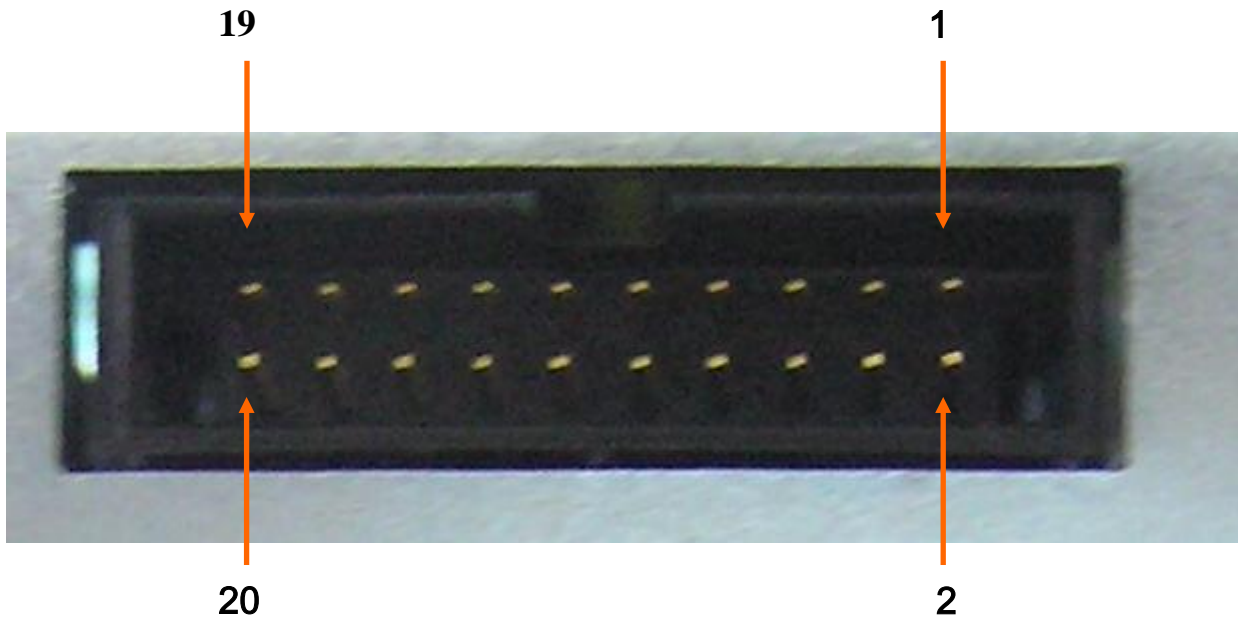

D.C Motor Control Table

INPUTS			FUNCTION
MOTOR_ENA	MOTOR_A	MOTOR_B	
H	L	H	Motor Regular Direction
H	H	L	Motor Reverse Direction
H	MOTOR_A = MOTOR_B		Fast Motor Stop
L	X	X	Feed Running Motor Stop

H : HIGH

L : LOW

X : Don't Care

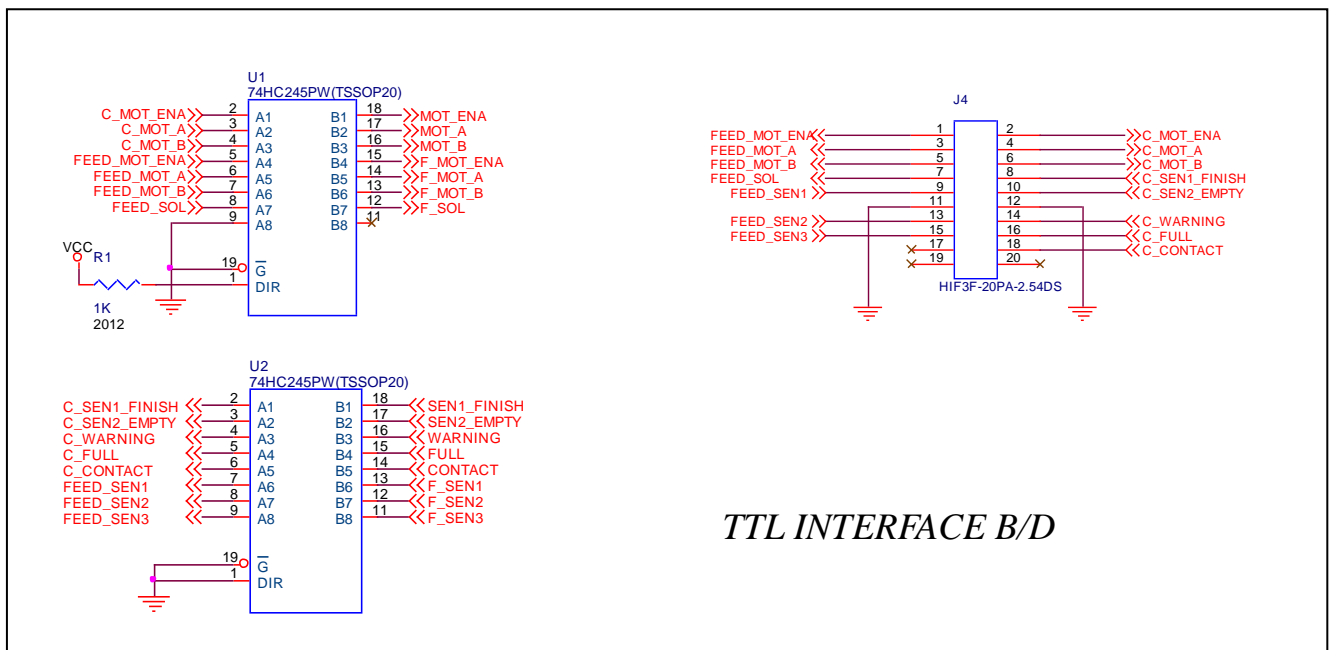

Doc No	CCM2000 SPECIFICATION	REV	PAGE	DATE
90000130		F	52 OF 57	2011. 03.08.

* FEED MODULE.

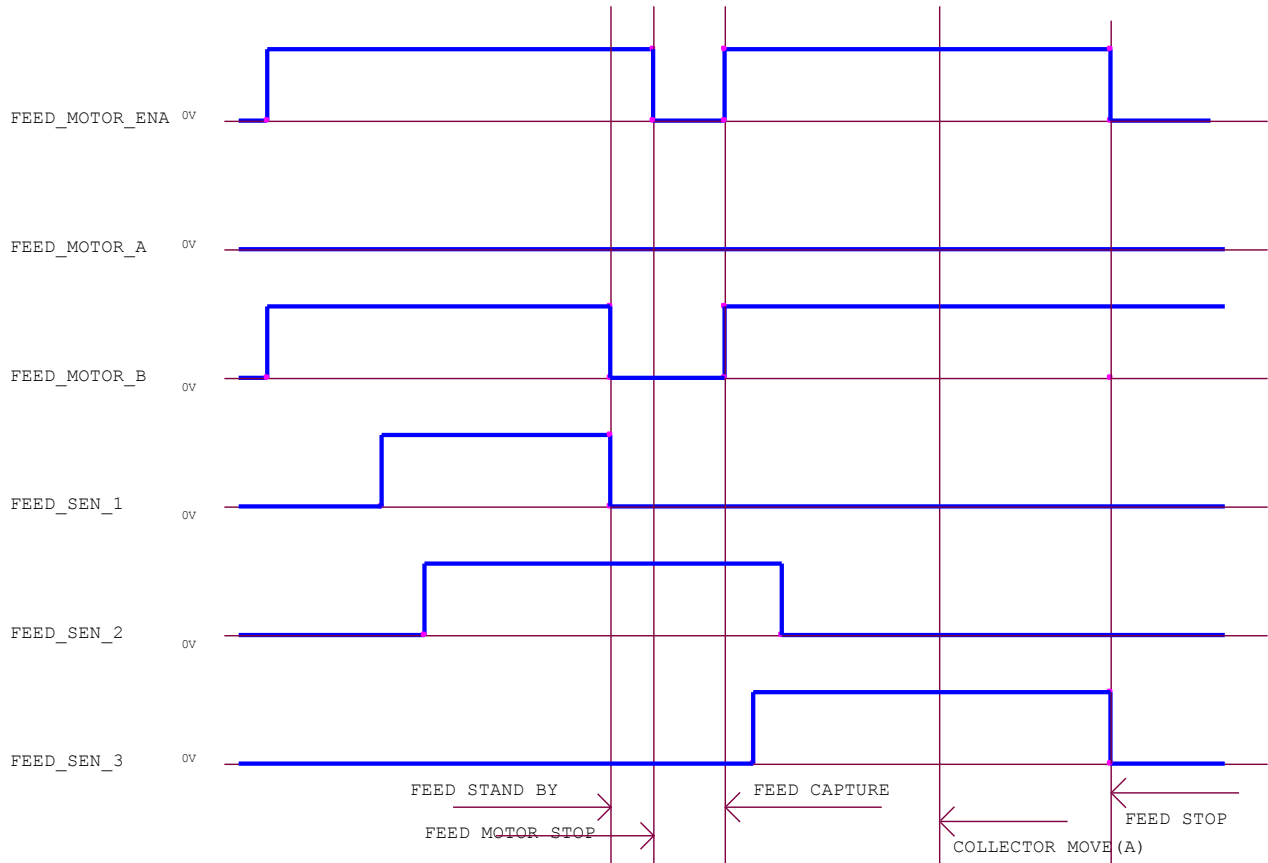

Doc No	CCM2000 SPECIFICATION	REV	PAGE	DATE
90000130		F	53 OF 57	2011. 03.08.

*COLLECTOR MOVE.

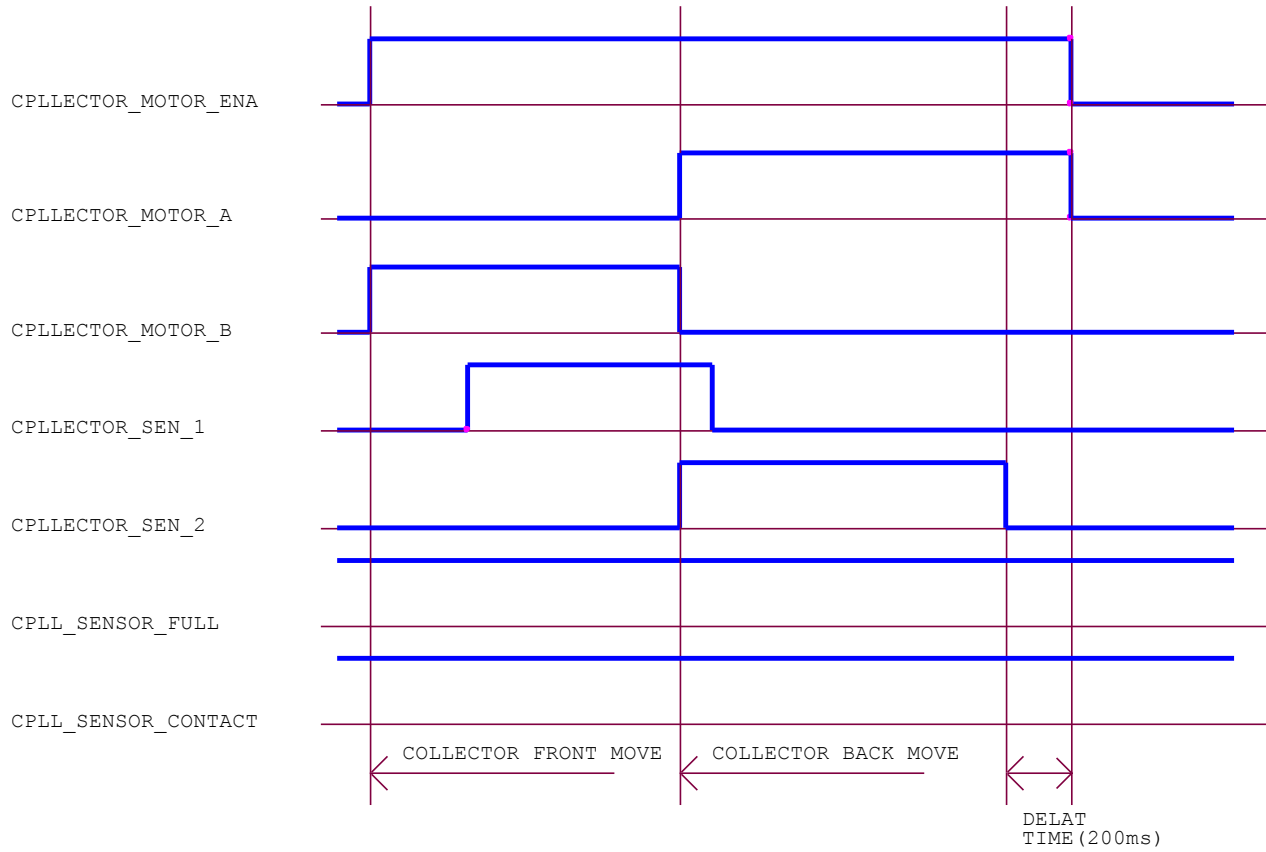

Doc No	CCM2000 SPECIFICATION	REV	PAGE	DATE
90000130		F	54 OF 57	2011. 03.08.

ERROR DETAIL

<GOOD>

Code : 0x0000

Description: Normal Execution

Procedures: None

<NOT_DEFINE_COMMAND>

Code : 0x2001

Description : Using the command that does not defined in this model.

Action : Use the valid command in this model.

<NOT_USE_COMMAND>

Code : 0x2002

Description : Not available command in this model.

Action : Use the valid command in this model.

<COMM_FRAME_ERROR>

Code : 0x2003

Description : Sending the command that has the invalid communication frame.

Action : Check the data format and the corresponding module specification.

<CARD_JAM>

Code : 0x2004

Description : When the card is jammed.

Action : Remove the jammed card.

<NO_CARD>

Code : 0x2005

Description : No cards.

Action : Insert the card.

Doc No	CCM2000 SPECIFICATION	REV	PAGE	DATE
90000130		F	55 OF 57	2011. 03.08.

<CARD_PRESENT>

Code : 0x2006

Description : When the card exists already in the terminal.

Action : Eject the card.

<BUSY>

Code : 0x2007

Description : When the terminal is running or busy.

Action : Wait until the previous operation is completed.

<RTC_ERROR>

Code : 0x2008

Description : When the RTC time is incorrect by internal terminal or incorrect input data.

Action : RTC time resetting

<TWO_MORE>

Code : 0x2009

Description : When more than two cards exit in the terminal simultaneously.

Action : Remove the Card .

<CARD_ERROR>

Code : 0x200B

Description : When the using card error, commonly occur in MSR.W.

Action : Exchange the Card

<COLLECTOR_ERROR>

Code : 0x2100

Description : Not Applicable Dispenser.

Action : Reset the terminal and exchange the dispenser..

< COLLECTOR _COMM_ERROR>

Code : 0x2101

Description : Dispenser communication error

Action : Check the communication line and reset the terminal.

Doc No	CCM2000 SPECIFICATION	REV	PAGE	DATE
90000130		F	56 OF 57	2011. 03.08.

<MSRW_ERROR>

Code : 0x2200

Description : The MS Reader/Writer that cannot use in this model.

Action : Change the MS Reader/Writer.

<MSRW_COMM_ERROR>

Code : 0x2201

Description : The MS Reader/Writer communication error.

Action : Check the communication line and reset the terminal.

<MSRW_WRITE_ERROR>

Code : 0x2202

Description : Error when the MS Reader/Writer is writing on the card.

Action : Clean the header and check the card.

<MSRW_READ_ERROR>

Code : 0x2203

Description : Error when the MS Reader/Writer is reading on the card.

Action : Clean the header and check the card.

<IC_CONTACT_ERROR>

Code : 0x2204

Description : Error while the terminal contacts the IC card.

Action : Be sure that the current card is an IC card.

<IC_CONTROL_ERROR>

Code : 0x2205

Description : Error while the terminal executes the IC card command.

Action : Check if the command is able to use in the contacted card.

<MS BLANK ERROR >

Code : 0x2209

Description : No data on the magnetic card

Action : Write data on the magnetic card.

Doc No	CCM2000 SPECIFICATION	REV	PAGE	DATE
90000130		F	57 OF 57	2011. 03.08.

<RF_ERROR>

Code : 0x2300

Description : Unavailable RF module.

Action : Change the RF MODULE

<RF_COMM_ERROR>

Code : 0x2301

Description : Communication error at the RF Module.

Action : Check the connection socket

<RF_AUTHEN_ERROR>

Code : 0x2302

Description : Authentication Error at the RF Module.

Action : Change the 'SECRET KEY'

<RF_WRITE_ERROR>

Code : 0x2303

Description : Error while the terminal writes at the RF Card.

Action : Be sure that the card exists in the detection range.

<RF_READ_ERROR>

Code : 0x2304

Description : Error while the terminal reads at the RF Card.

Action: Be sure that the card exists in the detection range.

<RF_DETECT_ERROR>

Error Code : 0x2305

Description : No RF Card.

Action : Insert the RF Card into the terminal.

<RF_VALUE_ERROR>

Code : 0x2306

Description : Error while the value increases(or decreases) at the RF Card.

Action: Be sure that the card exists in the detection range.

Doc No	CCM2000 SPECIFICATION	REV	PAGE	DATE
90000130		F	58 OF 57	2011. 03.08.

< COLLECTOR_NO_CARTRIDGE_ERROR >

Error Code : 0x2503

Description : There is no cartridge in Collector Machine

<COLLECTOR_CARTRIDGE_FULL_ERROR>

Error Code : 0x2505

Description : Collector Cartridge is Card full