



Ingeniería Electrónica
SMART IDENT

RF CARD ISSUING MACHINE

Specifications

User Manual

CHM-1800 Rev. B

Doc No	CHM18XXX SPECIFICATIONS	REV.	PAGE	DATE
			B	2 OF 35

RF Card Issuing Machine

Doc No	CHM18XXX SPECIFICATIONS	REV.	PAGE	DATE
		B	3 OF 35	2010. 12. 06.

REVISION HISTORY

NO.	DATE	DESCRIPTION	REV	PAGE
1	2008. 11. 22.	First Edition	A	34
2	2010. 12. 06	Add shutter type	B	

Doc No	CHM18XXX SPECIFICATIONS	REV.	PAGE	DATE
		B	4 OF 35	2010. 12. 06.

MODEL NAME INFORMATION

C H M - 1 8 X X X

INTERFACE	FUNCTION	RF	-	OPTION	CAPACITY		
RS-232C	1: SINGLE STACKER	8: RF ONLY	0: -	0: Without bezel 5: Shutter 6: Short Bezel	A: 0.76T	D: 0.76T	G: 0.76T
					B: 0.84T	E: 0.84T	H: 0.84T
					C: 1.0T	F: 1.0T	I: 1.0T
					200 PCS	300 PCS	500 PCS

Doc No	CHM18XXX SPECIFICATIONS	REV.	PAGE	DATE
		B	5 OF 35	2010. 12. 06.

C O N T E N T S

Overview

System Block Diagram

Specification

Magnetic Card Process

IC Card Process

RF Card Process

Communication Interface

Technical Drawing

Command Detail

Error Detail

Doc No	CHM18XXX SPECIFICATIONS	REV.	PAGE	DATE
			B	6 OF 35

OVERVIEW

All the processes and operations of CHM-18XXX are monitored by its intelligent Microprocessor, which makes itself self-recover function from faulty running.

CHM-18XXX has a function to takes an Error card back to the bin. This function is called "Capture".

This model also can be used for RF card conforming to the MIFARE.

Doc No	CHM18XXX SPECIFICATIONS	REV.	PAGE	DATE
		B	7 OF 35	2010. 12. 06.

SYSTEM BLOCK DIAGRAM

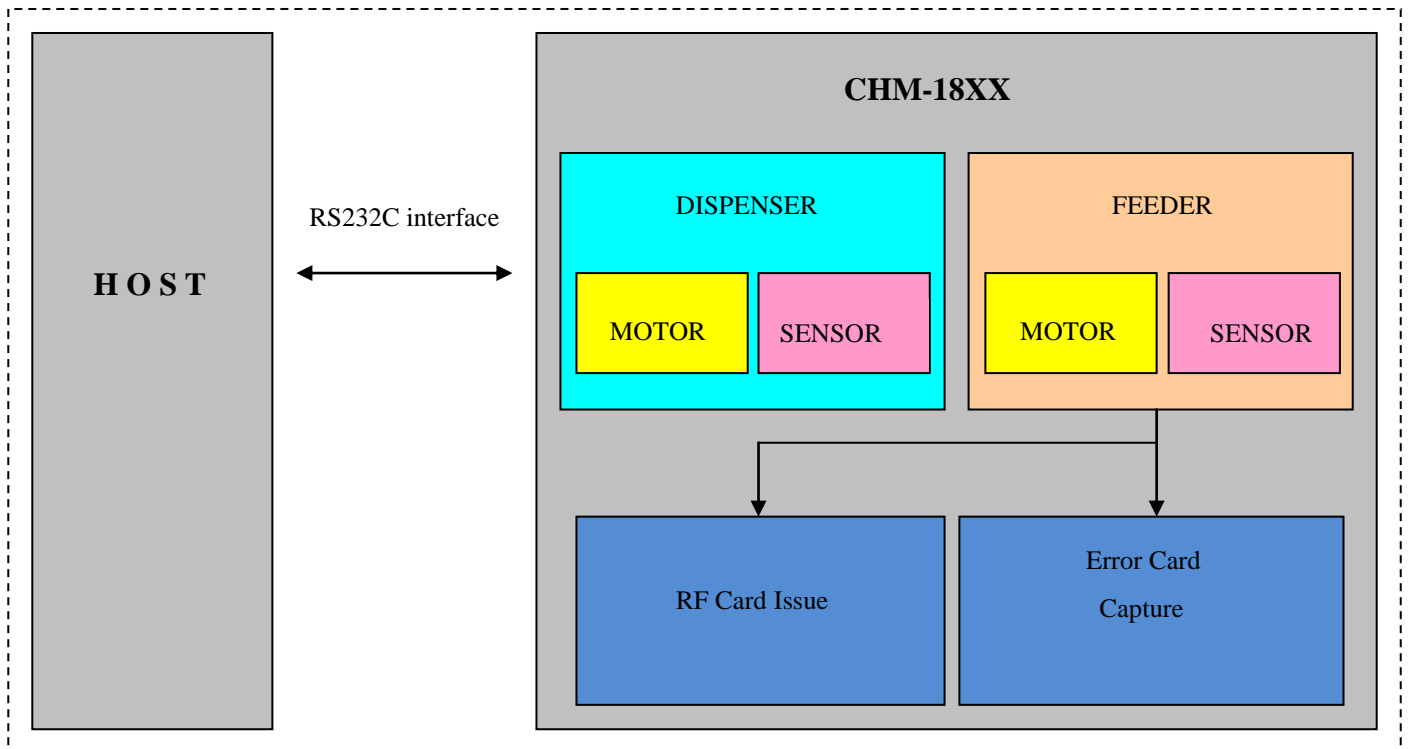

Doc No	CHM18XXX SPECIFICATIONS	REV.	PAGE	DATE
		B	8 OF 35	2010. 12. 06.

◆ *RS232C Connection*

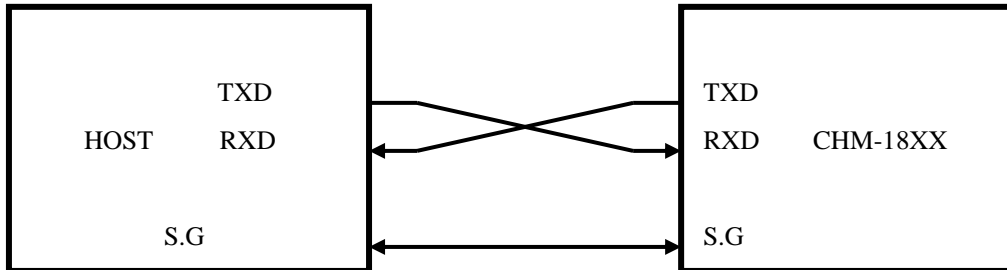

. Connector number: J1

Pin No.	INDEX	Remark
1	RXD	Receive
2	TXD	Transmit
3	S.G	Signal Ground

◆ *Power Connection*

Front View (male)

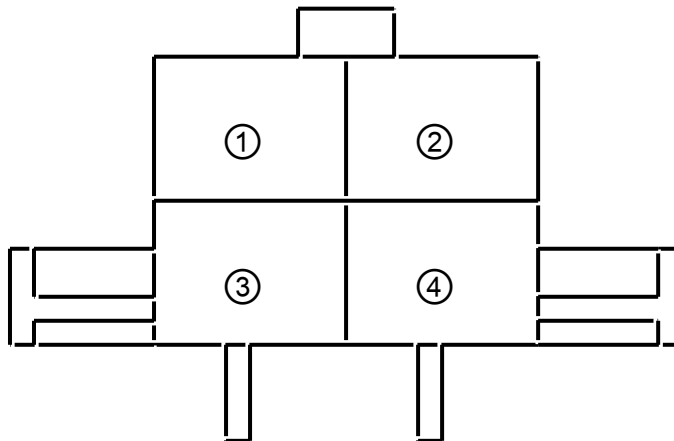

Pin No.	Signal Name	Direction
1	-	INPUT
2	DC +24V	
3	-	
4	GND	

Doc No	CHM18XXX SPECIFICATIONS	REV.	PAGE	DATE
		B	9 OF 35	2010. 12. 06.

SPECIFICATIONS

◆ *Basic functions*

	Spec.	Remark
Dimension	Refer to page 16	
Input power	DC 24V 3A	
Card Feeding Speed	2 ~ 5(Sec.)	

◆ *Environment Requirements*

Operating Locus: in door use only

Ambient Temperature

Storage: -20 °C to 70 °C (No functional error to be found in 12 hours after returning to normal environment)

Operating: 5 °C to 50°C (In 0°C to +5°C range, all specifications but 'Warped card' to be satisfied)

Ambient Relative Humidity

Storage: 0% to 95% RH (No functional error to be found in 12 hours after returning to normal environment)

Operating: 5 % 90% RH (No Condensation)

Vibration

: Amplitude 2mm, 10 to 50 Hz in X, Y, Z directions for 30min, 2G or less

Shock Endurance

: 30G, 11ms

Doc No	CHM18XXX SPECIFICATIONS	REV.	PAGE	DATE
		B	10 OF 35	2010. 12. 06.

RF CARD PROCESS

The RF module supports most of RF cards conforming with the ISO14443-3 Type A (MIFARE Card) with 8 Kbits memory.

◆ *Processing time:* Once Block

Command	Parameter	Time (mSec)		Note
		Type	Max	
Card Read	1 Block	100		Without card moving
Card Write	1 Block	150		Without card moving, With Verify
Card Decrement	1 Block	120		Without card moving
Card Increment	1 Block	120		Without Card moving

◆ *Operating Frequency*

Operating Frequency: 13.56 MHz

Data Transfer Baud: Baud rate 106K baud

Doc No	CHM18XXX SPECIFICATIONS	REV.	PAGE	DATE
		B	11 OF 35	2010. 12. 06.

COMMUNICATION INTERFACE

◆ *Communication Method*

- Asynchronous, Half duplex.
- Baud Rate: 9600 – 57600Bps, Default: 38400Bps
- Start Bit: 1Bit
- Data Length: 8Bit
- Parity: None
- Stop Bit: 1Bit

◆ *Communication Protocol Format*

1. *Command Frame Format.*

SOH	Null	Length	STX	CMD	DATA	ETX	BCC
1BYTE	1BYTE	2BYTE	1BYTE	3BYTE	N-BYTE	1BYTE	1BYTE

2. *Positive Response Frame Format*

SOH	Null	Length	STX	CMD	GOOD	0x01	DATA	ETX	BCC
1BYTE	1BYTE	2BYTE	1BYTE	3BYTE	1BYTE	1BYTE	N-BYTE	1BYTE	1BYTE

3. *Negative Response Frame Format*

SOH	Null	Length	STX	CMD	E-Code	0x00	ETX	BCC
1BYTE	1BYTE	2BYTE	1BYTE	3BYTE	2BYTE	1BYTE	1BYTE	1BYTE

4. *BCC (Check Sum)*

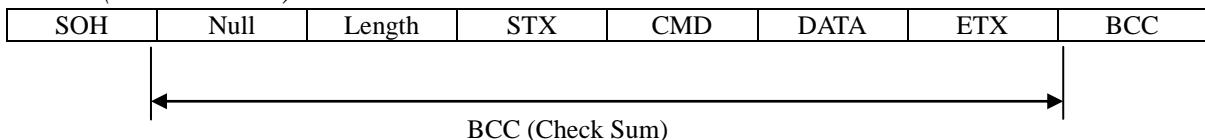

Command Frame BCC = Null ^ Length ^ STX ^ CMD ^ DATA ^ ETX.

Positive Response BCC = Null ^ Length ^ STX ^ CMD ^ GOOD ^ 0x01 ^ DATA ^ ETX.

Negative Response BCC = Null ^ Length ^ STX ^ CMD ^ E-Code ^ ETX.

N BYTE: Variable Length

Doc No	CHM18XXX SPECIFICATIONS	REV.	PAGE	DATE
		B	12 OF 35	2010. 12. 06.

5. Explanatory note of technical words

Name	Detail
NULL	Reserved. Always 0x00.
LENGTH	Data Length from the CMD to DATA.
CMD	Instruction Code (3 Bytes)
GOOD	Normal Execution : 0x0000 (2 Bytes)
E-Code	Command Failed: Refer to "Error Code" (2 Bytes)
BCC	Check Sum.

<Length>, <E-Code>

High Byte	Low Byte
-----------	----------

6. Control Characters

Name	Hex Value	Detail
SOH	0x01	Start of Heading Character
STX	0x02	Start of Text Character
ETX	0x03	End of Text Character
ENQ	0x05	Enquiry Character
ACK	0x06	Acknowledge Character
NAK	0x15	Negative Acknowledge Character
CAN	0x18	Cancel Character

7. COMMUNICATION SEQUENCE / TIMING

7.1 CHARACTER GUIDE TIME

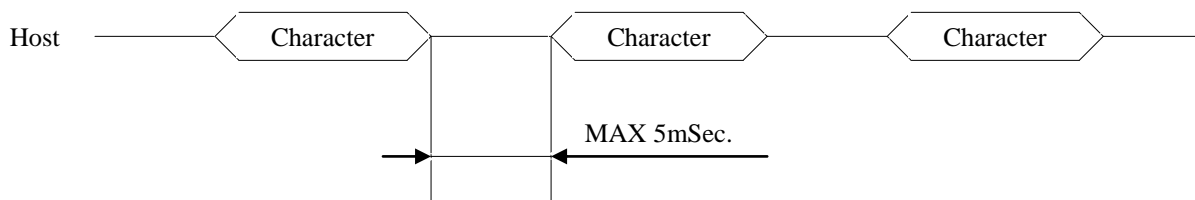

If no consecutive character within 5mSec, do time out.

Doc No	CHM18XXX SPECIFICATIONS	REV.	PAGE	DATE
		B	13 OF 35	2010. 12. 06.

7.2 Command

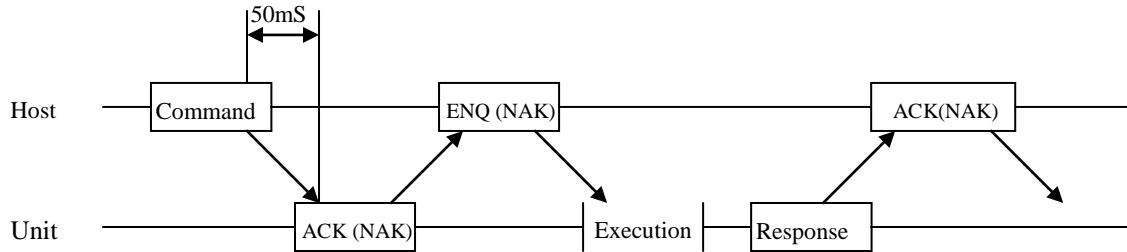

7.3 Inquiry

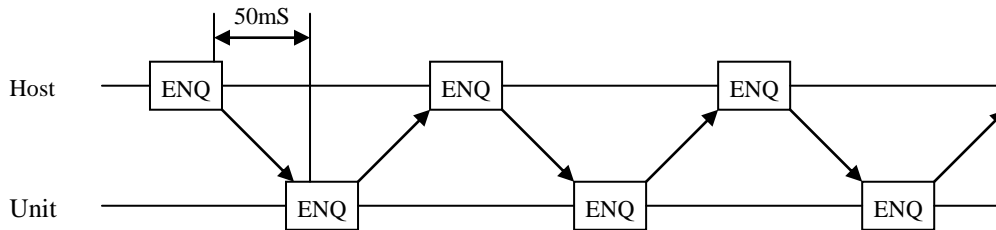

7.4 Sequence

7.3.1 General

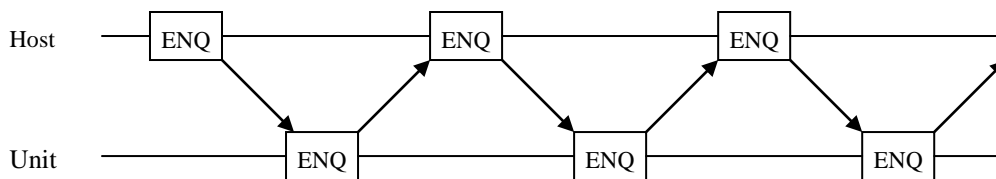
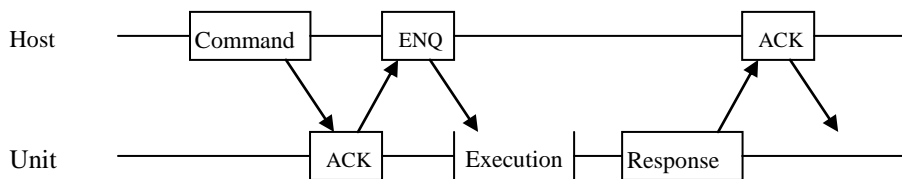

Doc No	CHM18XXX SPECIFICATIONS	REV.	PAGE	DATE
		B	14 OF 35	2010. 12. 06.

7.3.2 Error1

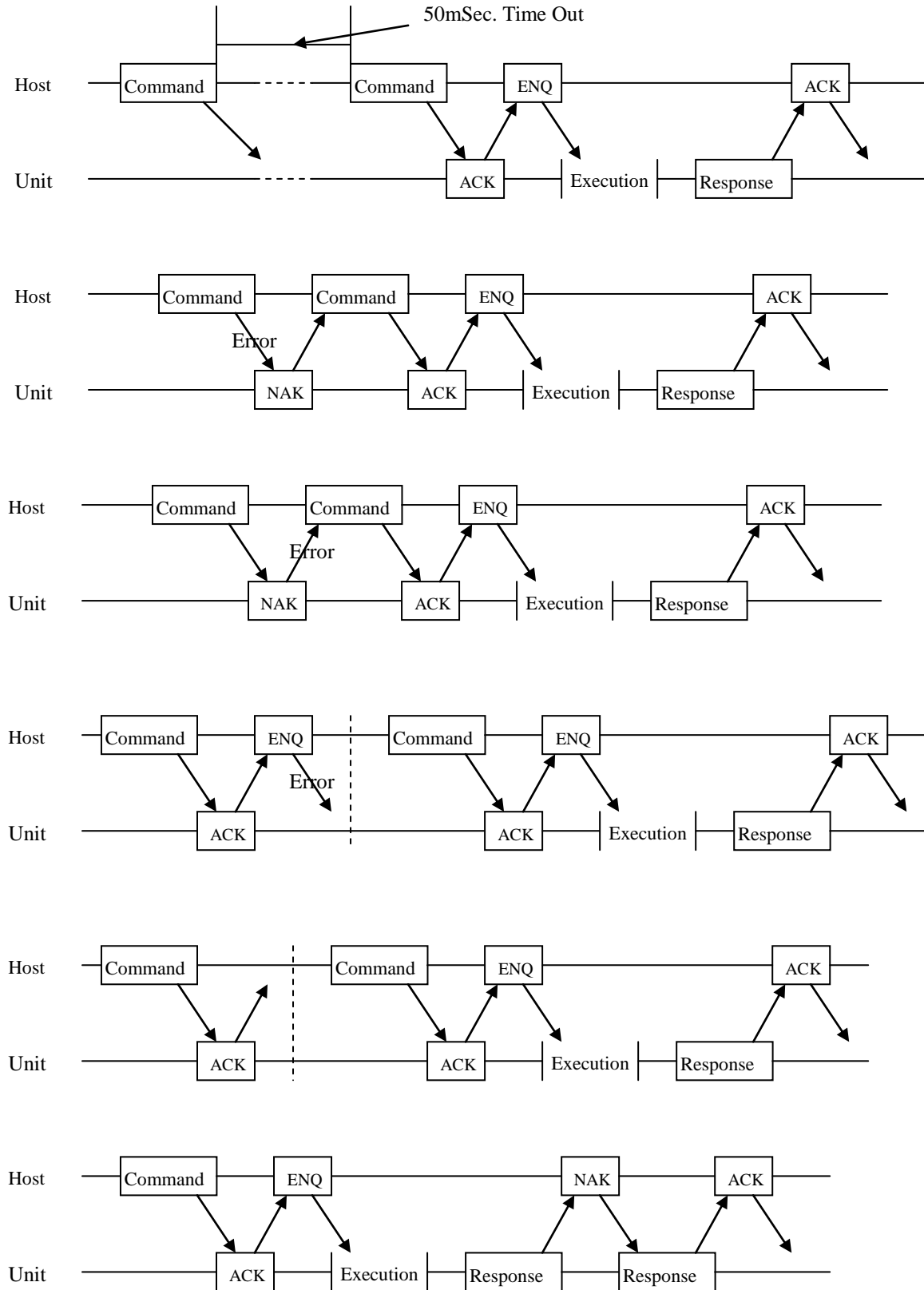

Doc No	CHM18XXX SPECIFICATIONS	REV.	PAGE	DATE
		B	15 OF 35	2010. 12. 06.

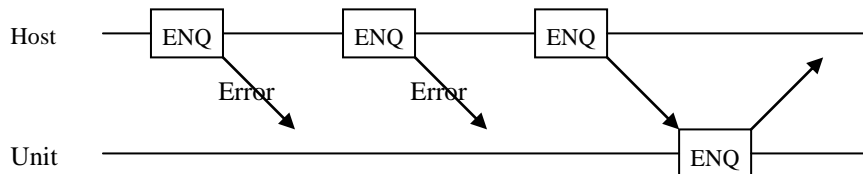
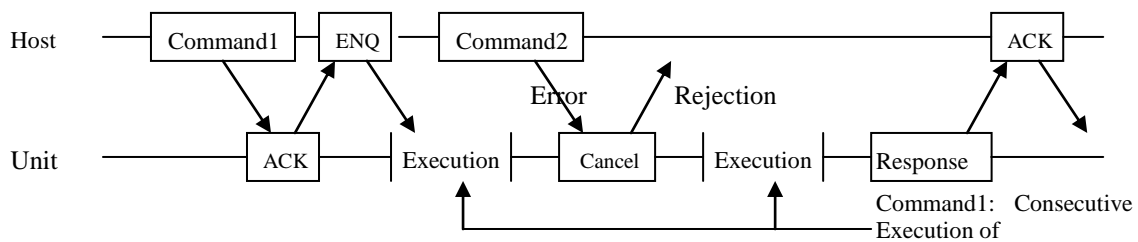
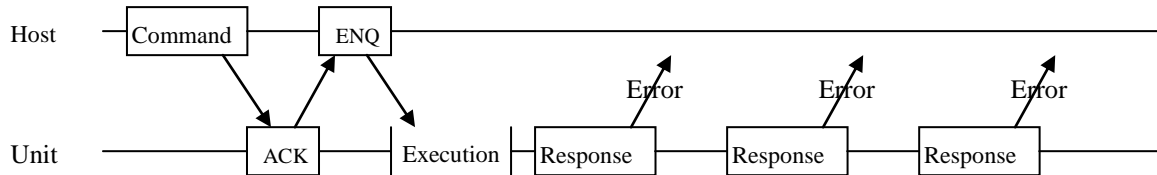
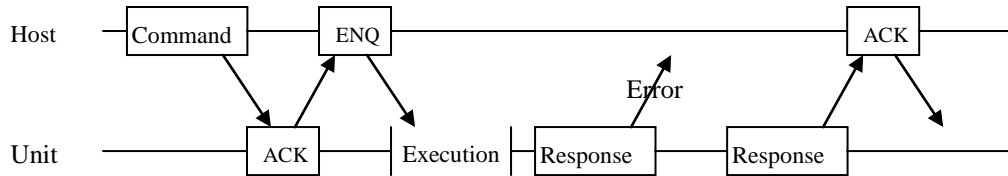
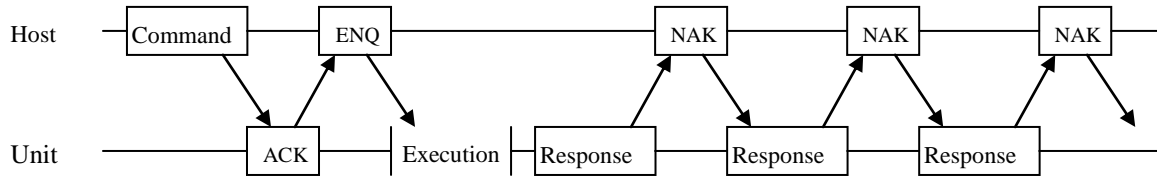
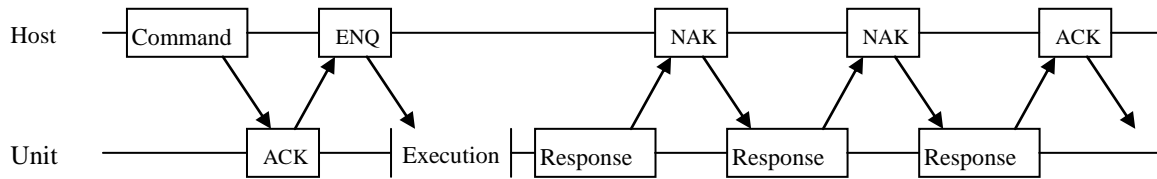

Doc No	CHM18XXX SPECIFICATIONS	REV.	PAGE	DATE
		B	16 OF 35	2010. 12. 06.

7.3.3 Error2

- When received the NAK packet consecutively.

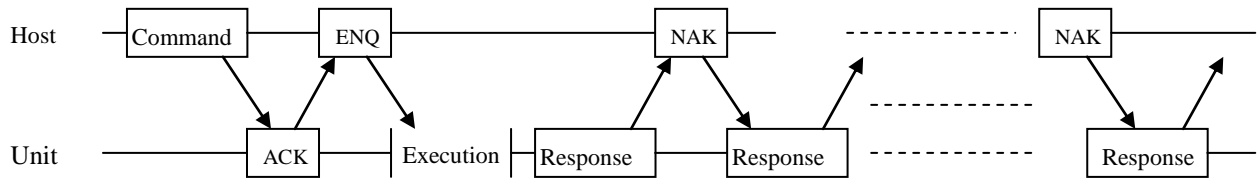

- When the Host sends the command without the ACK packet.

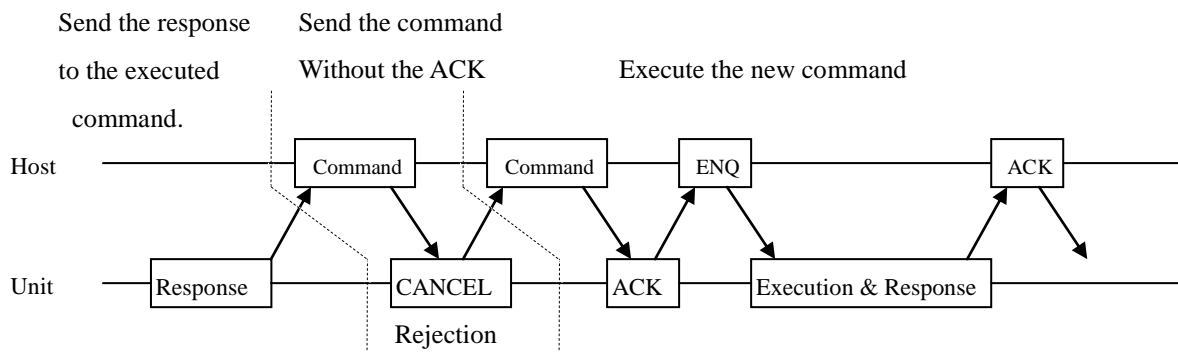

The terminal should ignore the command received before it sends the ACK packet, send the CANCEL packet. The second command will be treated as the ACK packet and executed with no ACK.

Doc No	CHM18XXX SPECIFICATIONS	REV.	PAGE	DATE
		B	17 OF 35	2010. 12. 06.

TECHNICAL DRAWING

*CHM -1806X, 1800X

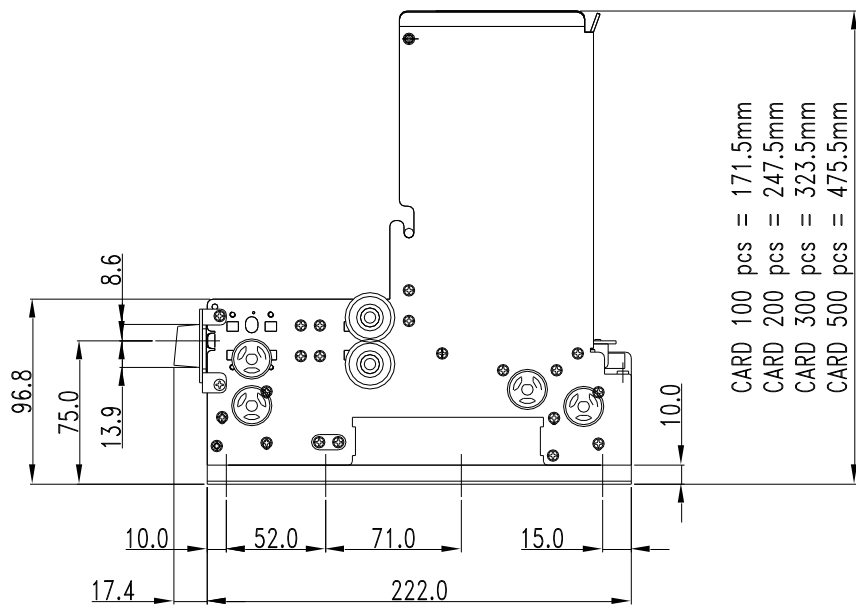
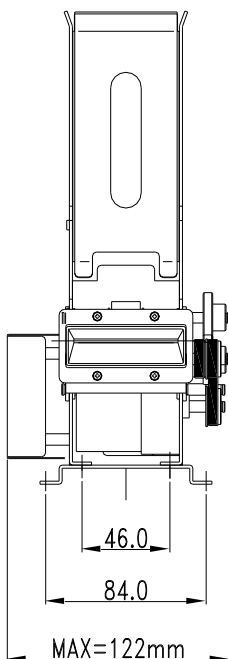
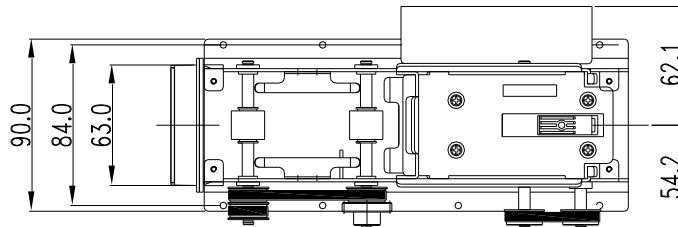

Doc No	CHM18XXX SPECIFICATIONS	REV.	PAGE	DATE
		B	18 OF 35	2010. 12. 06.

*CHM -1805X

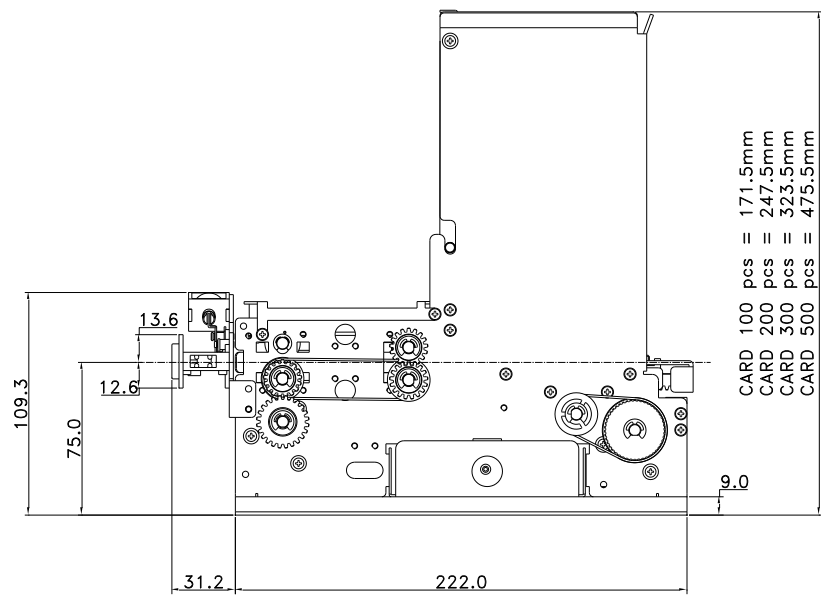
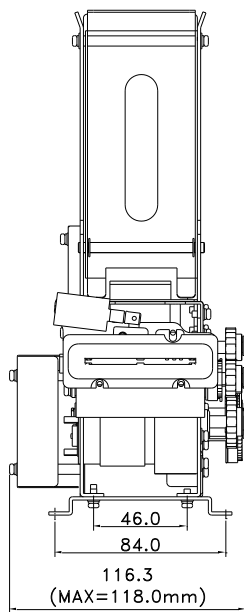
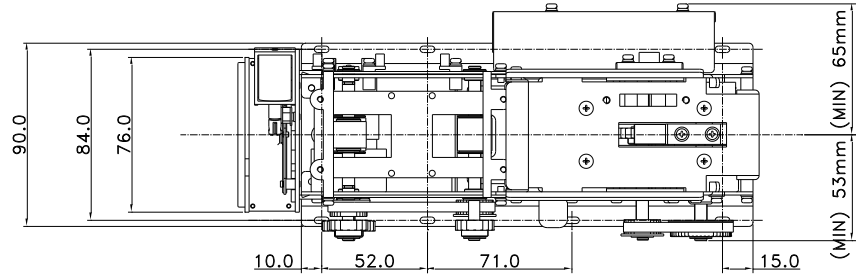

Doc No	CHM18XXX SPECIFICATIONS	REV.	PAGE	DATE
		B	19 OF 35	2010. 12. 06.

COMMAND DETAIL

◆ *Command List*

	Item	Cm0	Cm1	Cm2	Detail	Note
COMMON	STATUS1	'C'	'1'	'1'	Get Model	
		'C'	'1'	'2'	Get Firmware Version	
		'C'	'1'	'3'	Get Stacker	
		'C'	'1'	'6'	Get Card position	
	SETTING1	'C'	'2'	'6'	Set Baud Rate	
	MOVE	'C'	'3'	'1'	Card Move From Stacker	
		'C'	'3'	'2'	Card Move To ...	
		'C'	'3'	'3'	Card Eject	Forward
		'C'	'3'	'4'	Card Capture	Backward
		'C'	'3'	'6'	Card Drop 1)	Forward
RF CARD MIFARE 1K	RF CARD READ / WRITE	'R'	'3'	'1'	RF Card Read in Block Range	
		'R'	'3'	'2'	RF Card Write in Block Range	Verify**
		'R'	'3'	'6'	RF Card Read in Sector Range	
	BALANCE	'R'	'4'	'1'	Balance Increment	
		'R'	'4'	'2'	Balance Decrement	
	SECRET KEY CHANGE	'R'	'5'	'1'	Change 'Secret Key' to other Key	
		'R'	'5'	'2'	Change 'Secret Key' to all the same Key value	
		'R'	'5'	'3'	Select 'Secret Key Index'	
		'R'	'5'	'4'	Change 'RF Card Secret Key' to other Key	
	RF DETECT	'R'	'6'	'1'	Check RF card in antenna area	

* Command Check possible with setting the terminal.

** After command execution, verify execution automatically.

1) The CHM-18XX model with bezel or shutter can't use "C36" command.

Doc No	CHM18XXX SPECIFICATIONS	REV.	PAGE	DATE
		B	20 OF 35	2010. 12. 06.

◆ *Common*

1. STATUS / SETTING

1.1 “C11”: It is to check out Model number of CHM-18XX.

☞ Command Format

SOH	Null	Length	STX	“C11”	ETX	Bcc
-----	------	--------	-----	-------	-----	-----

☞ Positive Response Format

SOH	Null	Length	STX	“C11”	GOOD	0x01	DATA	ETX	Bcc
-----	------	--------	-----	-------	------	------	------	-----	-----

☞ Negative Response Format

SOH	Null	Length	STX	“C11”	E-Code	0x00	ETX	Bcc
-----	------	--------	-----	-------	--------	------	-----	-----

☞ Response Data Structure

Model No	
8Byte (ASCII)	

1.2 “C12”: It is to check out Firmware Version of CHM-18XX

☞ Command Format

SOH	Null	Length	STX	“C12”	ETX	Bcc
-----	------	--------	-----	-------	-----	-----

☞ Positive Response Format

SOH	Null	Length	STX	“C12”	GOOD	0x01	DATA	ETX	Bcc
-----	------	--------	-----	-------	------	------	------	-----	-----

☞ Negative Response Format

SOH	Null	Length	STX	“C12”	E-Code	0x00	ETX	Bcc
-----	------	--------	-----	-------	--------	------	-----	-----

☞ Response Data Structure

Firmware Version	
9Byte (ASCII)	

Doc No	CHM18XXX SPECIFICATIONS	REV.	PAGE	DATE
		B	21 OF 35	2010. 12. 06.

1.3 "C13": It is check out status of Stacker of CHM-18XX

☞ Command Format

SOH	Null	Length	STX	"C13"	ETX	Bcc
-----	------	--------	-----	-------	-----	-----

☞ Positive Response Format

SOH	Null	Length	STX	"C13"	GOOD	0x01	DATA	ETX	Bcc
-----	------	--------	-----	-------	------	------	------	-----	-----

☞ Negative Response Format

SOH	Null	Length	STX	"C13"	E-Code	0x00	ETX	Bcc
-----	------	--------	-----	-------	--------	------	-----	-----

☞ Response Data Structure

Stacker	0x00
1Byte (Hex)	1Byte (Hex)

☞ Data Variable

<Stacker>

Code	Status	Note
0x01	Stacker Good	
0x02	Card Warning	
0x03	Stacker Empty	

☞ Note

Stacker Status	Detail
'Stacker Good'	Good.
'Card Warning'	A few Card in the stacker
'Stacker Empty'	No cards in the stacker

-Warning Sensor Setting

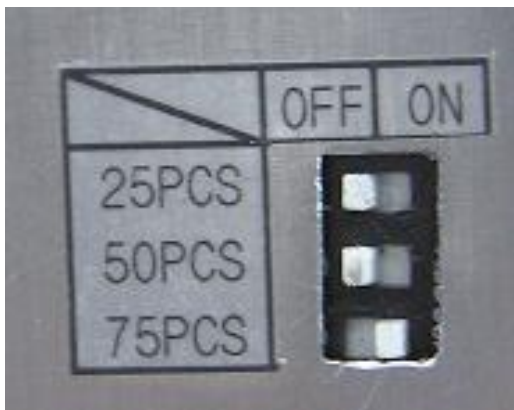

Set Value	25pcs	50pcs	75pcs
Set to 25pcs cards	ON	OFF	OFF
Set to 50pcs cards	OFF	ON	OFF
Set to 75pcs cards	OFF	OFF	ON

Doc No	CHM18XXX SPECIFICATIONS	REV.	PAGE	DATE
		B	22 OF 35	2010. 12. 06.

1.4 "C16": The card is check by existent location.

☞ Command Format

SOH	Null	Length	STX	"C16"	ETX	Bcc
-----	------	--------	-----	-------	-----	-----

☞ Positive Response Format

SOH	Null	Length	STX	"C16"	GOOD	0x01	DATA	ETX	Bcc
-----	------	--------	-----	-------	------	------	------	-----	-----

☞ Negative Response Format

SOH	Null	Length	STX	"C16"	E-Code	0x00	ETX	Bcc
-----	------	--------	-----	-------	--------	------	-----	-----

☞ Response Data Structure

Card Position
1Byte (Hex)

☞ Data Variable

<Card Position>

Code	Sensor	Detail
0x01	SEN1	The card is locate NO.1
0x02	SEN2	The card is locate NO.2
0x04	SEN3	The card is locate NO.3

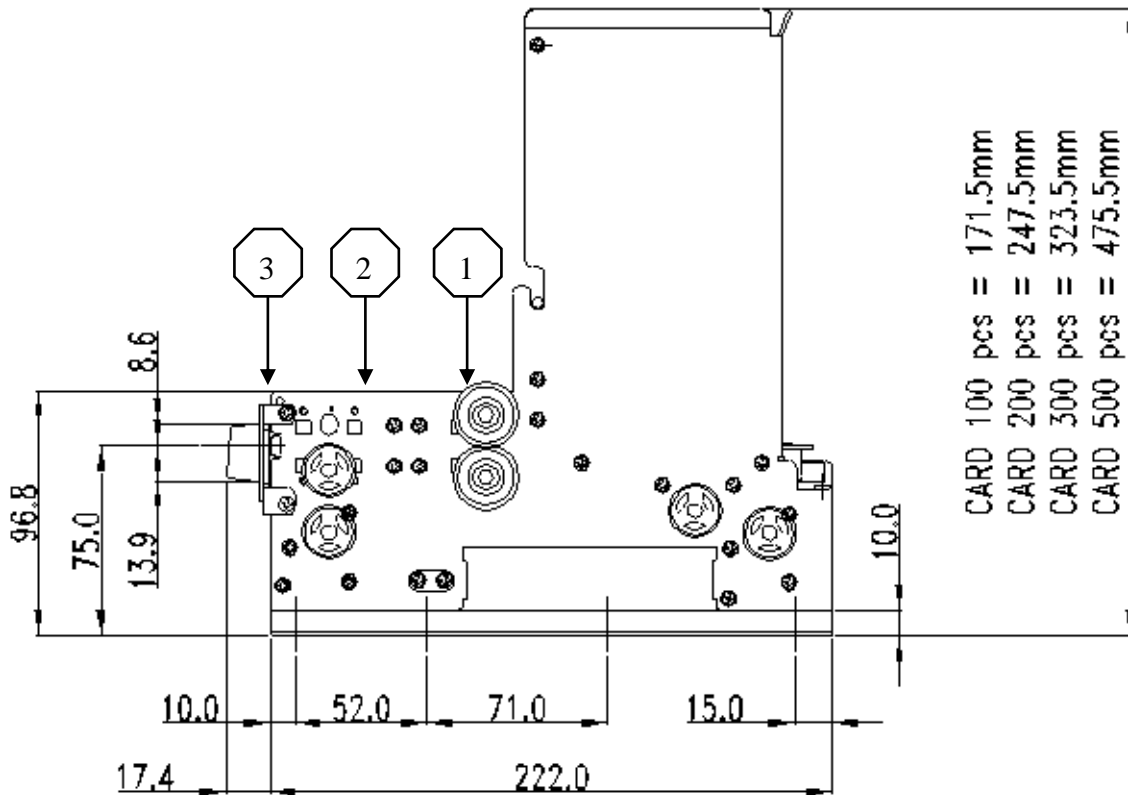

Doc No	CHM18XXX SPECIFICATIONS	REV.	PAGE	DATE
		B	23 OF 35	2010. 12. 06.

2. SETTING

2.3 “C26”: It is to change ‘Baud Rate’.

☞ Command Format

SOH	Null	Length	STX	“C26”	DATA	ETX	Bcc
-----	------	--------	-----	-------	------	-----	-----

☞ Command Data Structure

Baud Rate
1Byte (Hex)

☞ Positive Response Format

SOH	Null	Length	STX	“C26”	GOOD	0x01	ETX	Bcc
-----	------	--------	-----	-------	------	------	-----	-----

☞ Negative Response Format

SOH	Null	Length	STX	“C26”	E-Code	0x00	ETX	Bcc
-----	------	--------	-----	-------	--------	------	-----	-----

☞ Response Data Structure

☞ Data Variable

<Baud Rate>

Code	Setting	Detail	Note
0x01	9600Bps	Set Baud Rate to be 9600Bps	
0x02	19200Bps	Set Baud Rate to be 19200Bps	
0x04	38400Bps	Set Baud Rate to be 38400Bps	Default
0x05	57600Bps	Set Baud Rate to be 57600Bps	

Doc No	CHM18XXX SPECIFICATIONS	REV.	PAGE	DATE
		B	24 OF 35	2010. 12. 06.

3. MOVE

3.1 “C31”: It is to take a card from Stacker and to move it to Card Reader / Writer Module.

☞ Command Format

SOH	Null	Length	STX	“C31”	DATA	ETX	Bcc
-----	------	--------	-----	-------	------	-----	-----

☞ Command Data Structure

0x00	Module
1Byte (Hex)	1Byte (Hex)

☞ Positive Response Format

SOH	Null	Length	STX	“C31”	GOOD	0x01	ETX	Bcc
-----	------	--------	-----	-------	------	------	-----	-----

☞ Negative Response Format

SOH	Null	Length	STX	“C31”	E-Code	0x00	ETX	Bcc
-----	------	--------	-----	-------	--------	------	-----	-----

☞ Data Variable

<Module>

Code	Setting	Detail
0x03	RF	Card transport to RF Module

3.2 “C32”: It is take card to Card Reader / Writer Module

☞ Command Format

SOH	Null	Length	STX	“C32”	DATA	ETX	Bcc
-----	------	--------	-----	-------	------	-----	-----

☞ Command Data Structure

Module
1Byte (Hex)

☞ Positive Response Format

SOH	Null	Length	STX	“C32”	GOOD	0x01	DATA	ETX	Bcc
-----	------	--------	-----	-------	------	------	------	-----	-----

☞ Negative Response Format

SOH	Null	Length	STX	“C32”	E-Code	0x00	ETX	Bcc
-----	------	--------	-----	-------	--------	------	-----	-----

☞ Data Variable

<Module>

Code	Setting	Detail
0x03	RF	Card transport to RF Module

Doc No	CHM18XXX SPECIFICATIONS	REV.	PAGE	DATE
		B	25 OF 35	2010. 12. 06.

3.3 “C33”: It is to dispense out card to the front.

☞ Command Format

SOH	Null	Length	STX	“C33”	ETX	Bcc
-----	------	--------	-----	-------	-----	-----

☞ Positive Response Format

SOH	Null	Length	STX	“C33”	GOOD	0x01	ETX	Bcc
-----	------	--------	-----	-------	------	------	-----	-----

☞ Negative Response Format

SOH	Null	Length	STX	“C33”	E-Code	0x00	ETX	Bcc
-----	------	--------	-----	-------	--------	------	-----	-----

3.4 “C34”: It takes card to Bin Box (Capture)

☞ Command Format

SOH	Null	Length	STX	“C34”	ETX	Bcc
-----	------	--------	-----	-------	-----	-----

☞ Positive Response Format

SOH	Null	Length	STX	“C34”	GOOD	0x01	ETX	Bcc
-----	------	--------	-----	-------	------	------	-----	-----

☞ Negative Response Format

SOH	Null	Length	STX	“C34”	E-Code	0x00	ETX	Bcc
-----	------	--------	-----	-------	--------	------	-----	-----

3.5 “C36”: Dispense the card to front and drop it out of the unit.

☞ Command Format

SOH	Null	Length	STX	“C36”	ETX	Bcc
-----	------	--------	-----	-------	-----	-----

☞ Positive Response Format

SOH	Null	Length	STX	“C36”	GOOD	0x01	ETX	Bcc
-----	------	--------	-----	-------	------	------	-----	-----

☞ Negative Response Format

SOH	Null	Length	STX	“C36”	E-Code	0x00	ETX	Bcc
-----	------	--------	-----	-------	--------	------	-----	-----

☞ Note

The CHM-18XX model with bezel or shutter can't use “C36” command.

Doc No	CHM18XXX SPECIFICATIONS	REV.	PAGE	DATE
		B	26 OF 35	2010. 12. 06.

◆ *RF CARD*

This section describes the commands that can use at the 'RF CARD'.

The RF Module of his model supports only the MIFARE card.

Item	Cm0	Cm1	Cm2	Detail	Note
RF CARD READ / WRITE	'R'	'3'	'1'	RF Card Read in Block Range	
	'R'	'3'	'2'	RF Card Write in Block Range	Verify
	'R'	'3'	'6'	RF Card Read in Sector Range	
BALANCE	'R'	'4'	'1'	Balance Increment	
	'R'	'4'	'2'	Balance Decrement	
SECRET KEY CHANGE	'R'	'5'	'1'	Change 'Secret Key' to other Key	
	'R'	'5'	'2'	Change 'Secret Key' to all the same Key value	
	'R'	'5'	'3'	Select 'Secret Key Index'	
	'R'	'5'	'4'	Change 'RF Card Secret Key' to other Key	
RF DETECT	'R'	'6'	'1'	Check RF card in antenna area	

To use the RF card, you need to initialize at first.

- Setting and updating of the secret key and secret key index.

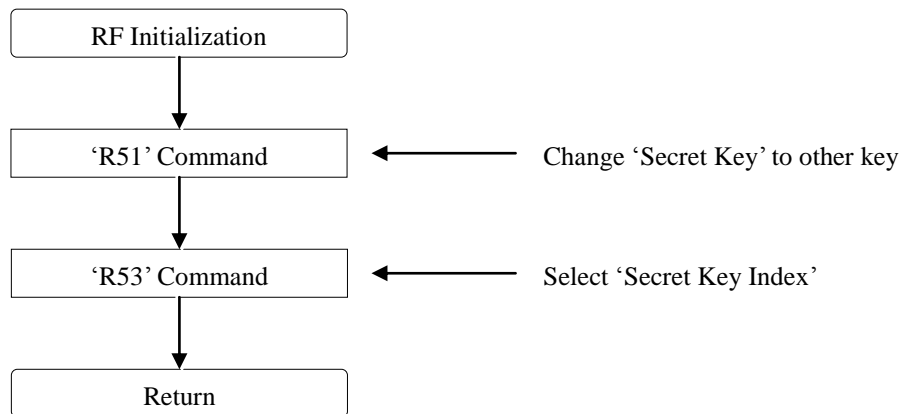

RF Module Initialization

Doc No	CHM18XXX SPECIFICATIONS	REV.	PAGE	DATE
		B	27 OF 35	2010. 12. 06.

Basic Operating Procedure of the RF card:

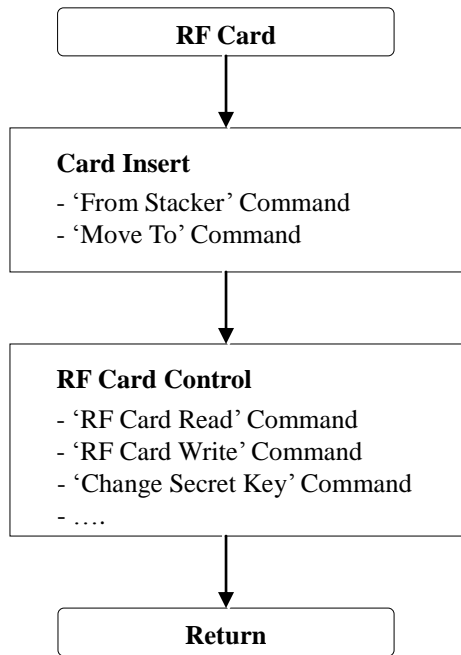

RF Card Basic Operating Procedures

Memory Architecture (map) of the RF card: 8Kbyte

Sector	Block	Size	Detail	Note
Sector 0	Block 0	16Byte	RF Card Information	Can't use
	Block 1	16Byte		
	Block 2	16Byte		
	Block 3	16Byte	'Sector Key'	
Sector 1	Block 0	16Byte	User Available Memory	
	Block 1	16Byte		
	Block 2	16Byte		
	Block 3	16Byte	'Sector Key'	
Sector 2	Block 0	16Byte	User Available Memory	
	Block 1	16Byte		
	Block 2	16Byte		
	Block 3	16Byte	'Sector Key'	
---	---	---	---	---
Sector 15	Block 0	16Byte	User Available Memory	
	Block 1	16Byte		
	Block 2	16Byte		
	Block 3	16Byte	'Sector Key'	

Doc No	CHM18XXX SPECIFICATIONS	REV.	PAGE	DATE
		B	28 OF 35	2010. 12. 06.

1. RF CARD READ / WRITE

1.1 "R31": Read RF card data & Secret Key in block range

☞ Command Format

SOH	Null	Length	STX	"R31"	DATA	ETX	Bcc
-----	------	--------	-----	-------	------	-----	-----

☞ Command Data Structure

Sector	Block
0x00 – 0x0f	0x00 – 0x03
1Byte (Hex)	1Byte (Hex)

☞ Positive Response Format

SOH	Null	Length	STX	"R31"	GOOD	0x01	DATA	ETX	Bcc
-----	------	--------	-----	-------	------	------	------	-----	-----

☞ Negative Response Format

SOH	Null	Length	STX	"R31"	E-Code	0x00	ETX	Bcc
-----	------	--------	-----	-------	--------	------	-----	-----

☞ Response Data Structure

Sector	Block	Read Data												
1Byte (Hex)	1Byte (Hex)	16 Byte (Hex)												
<table border="1" style="margin-left: 100px;"> <tr> <td>D0</td> <td>D1</td> <td>D2</td> <td>---</td> <td>D14</td> <td>D15</td> </tr> <tr> <td>1Byte</td> <td>1Byte</td> <td>1Byte</td> <td>---</td> <td>1Byte</td> <td>1Byte</td> </tr> </table>			D0	D1	D2	---	D14	D15	1Byte	1Byte	1Byte	---	1Byte	1Byte
D0	D1	D2	---	D14	D15									
1Byte	1Byte	1Byte	---	1Byte	1Byte									

1.2 "R32": Write RF card data in block range

☞ Command Format

SOH	Null	Length	STX	"R32"	DATA	ETX	Bcc
-----	------	--------	-----	-------	------	-----	-----

☞ Command Data Structure

Sector	Block	Write Data												
0x00 – 0x0f	0x00 – 0x02	0x00 – 0xff												
1Byte (Hex)	1Byte (Hex)	16Byte (Hex)												
<table border="1" style="margin-left: 100px;"> <tr> <td>D0</td> <td>D1</td> <td>D2</td> <td>---</td> <td>D14</td> <td>D15</td> </tr> <tr> <td>1Byte</td> <td>1Byte</td> <td>1Byte</td> <td>---</td> <td>1Byte</td> <td>1Byte</td> </tr> </table>			D0	D1	D2	---	D14	D15	1Byte	1Byte	1Byte	---	1Byte	1Byte
D0	D1	D2	---	D14	D15									
1Byte	1Byte	1Byte	---	1Byte	1Byte									

☞ Positive Response Format

SOH	Null	Length	STX	"R32"	GOOD	0x01	ETX	Bcc
-----	------	--------	-----	-------	------	------	-----	-----

☞ Negative Response Format

SOH	Null	Length	STX	"R32"	E-Code	0x00	ETX	Bcc
-----	------	--------	-----	-------	--------	------	-----	-----

Doc No	CHM18XXX SPECIFICATIONS	REV.	PAGE	DATE
		B	29 OF 35	2010. 12. 06.

1.3 “R36”: Read RF card data in sector range

☞ Command Format

SOH	Null	Length	STX	“R36”	DATA	ETX	Bcc
-----	------	--------	-----	-------	------	-----	-----

☞ Command Data Structure

Sector
0x00 – 0x0f
1Byte (Hex)

☞ Positive Response Format

SOH	Null	Length	STX	“R36”	GOOD	0x01	DATA	ETX	Bcc
-----	------	--------	-----	-------	------	------	------	-----	-----

☞ Negative Response Format

SOH	Null	Length	STX	“R36”	E-Code	0x00	ETX	Bcc
-----	------	--------	-----	-------	--------	------	-----	-----

☞ Response Data Structure

Sector	0x00	Read Data (0)	0x01	Read Data (1)	0x02	Read Data (2)
1Byte(Hex)	1Byte(Hex)	16Byte (Hex)	1Byte (Hex)	16Byte (Hex)	1Byte (Hex)	16Byte (Hex)

D0	D1	D2	---	D14	D15
1Byte	1Byte	1Byte	---	1Byte	1Byte

1.4 “R37”: Write RF card data in sector range (except Sector 0)

☞ Command Format

SOH	Null	Length	STX	“R37”	DATA	ETX	Bcc
-----	------	--------	-----	-------	------	-----	-----

☞ Command Data Structure

Sector	Write Data
0x01 – 0x0f	0x00 – 0xff
1Byte (Hex)	51Byte (Hex)

0x00	Read Data (0)	0x01	Read Data (1)	0x02	Read Data (2)
1Byte (Hex)	16Byte (Hex)	1Byte (Hex)	16Byte (Hex)	1Byte (Hex)	16Byte (Hex)

D0	D1	D2	---	D14	D15
1Byte	1Byte	1Byte	---	1Byte	1Byte

☞ Positive Response Format

SOH	Null	Length	STX	“R37”	GOOD	0x01	ETX	Bcc
-----	------	--------	-----	-------	------	------	-----	-----

☞ Negative Response Format

SOH	Null	Length	STX	“R37”	E-Code	0x00	ETX	Bcc
-----	------	--------	-----	-------	--------	------	-----	-----

Doc No	CHM18XXX SPECIFICATIONS	REV.	PAGE	DATE
		B	30 OF 35	2010. 12. 06.

2 BALANCE

2.1 “R41”: Increment the balance of card to the specified amount.

☞ Command Format

SOH	Null	Length	STX	“R41”	DATA	ETX	Bcc
-----	------	--------	-----	-------	------	-----	-----

☞ Command Data Structure

Sector	Block	Index Value
0x00 – 0x0f	0x00 – 0x02	0x00000000 – 0xffffffff
1Byte (Hex)	1Byte (Hex)	4Byte (Hex)

V0	V1	V2	V3
0x00-0xff	0x00-0xff	0x00-0xff	0x00-0xff
1Byte(Hex, LSB)	1Byte(Hex)	1Byte(Hex)	1Byte(Hex, MSB)

☞ Positive Response Format

SOH	Null	Length	STX	“R41”	GOOD	0x01	ETX	Bcc
-----	------	--------	-----	-------	------	------	-----	-----

☞ Negative Response Format

SOH	Null	Length	STX	“R41”	E-Code	0x00	ETX	Bcc
-----	------	--------	-----	-------	--------	------	-----	-----

☞ Note

The balance should be written in the Electronic Purse format in the card.

2.1 “R42”: Decrement the balance of card to the specified amount..

☞ Command Format

SOH	Null	Length	STX	“R42”	DATA	ETX	Bcc
-----	------	--------	-----	-------	------	-----	-----

☞ Command Data Structure

Sector	Block	Index Value
0x00 – 0x0f	0x00 – 0x02	0x00000000 – 0xffffffff
1Byte (Hex)	1Byte (Hex)	4Byte (Hex)

V0	V1	V2	V3
0x00-0xff	0x00-0xff	0x00-0xff	0x00-0xff
1Byte(Hex, LSB)	1Byte(Hex)	1Byte(Hex)	1Byte(Hex, MSB)

☞ Positive Response Format

SOH	Null	Length	STX	“R42”	GOOD	0x01	ETX	Bcc
-----	------	--------	-----	-------	------	------	-----	-----

☞ Negative Response Format

SOH	Null	Length	STX	“R42”	E-Code	0x00	ETX	Bcc
-----	------	--------	-----	-------	--------	------	-----	-----

☞ Note

The balance should be written in the Electronic Purse format in the card.

Doc No	CHM18XXX SPECIFICATIONS	REV.	PAGE	DATE
		B	31 OF 35	2010. 12. 06.

3 SECRET KEY

3.1 "R51": Change 'Secret Key' to a new key

☞ Command Format

SOH	Null	Length	STX	"R51"	DATA	ETX	Bcc
-----	------	--------	-----	-------	------	-----	-----

☞ Command Data Structure

Sector	KEY A	KEY B
0x00 – 0x0f	0x00 – 0xff	0x00 – 0xff
1Byte (Hex)	6Byte (Hex)	6Byte (Hex)

☞ Positive Response Format

SOH	Null	Length	STX	"R51"	GOOD	0x01	ETX	Bcc
-----	------	--------	-----	-------	------	------	-----	-----

☞ Negative Response Format

SOH	Null	Length	STX	"R51"	E-Code	0x00	ETX	Bcc
-----	------	--------	-----	-------	--------	------	-----	-----

☞ Note

CHM-18XXX Series 'Secret Key'

KEY A: FFFFFFFFFF

KEY B: FFFFFFFFFF

3.2 "R52": Change 'Secret Key' to all the same key value

☞ Command Format

SOH	Null	Length	STX	"R52"	DATA	ETX	Bcc
-----	------	--------	-----	-------	------	-----	-----

☞ Command Data Structure

KEY A	KEY B
0x00 – 0xff	0x00 – 0xff
6Byte (Hex)	6Byte (Hex)

☞ Positive Response Format

SOH	Null	Length	STX	"R52"	GOOD	0x01	ETX	Bcc
-----	------	--------	-----	-------	------	------	-----	-----

☞ Negative Response Format

SOH	Null	Length	STX	"R52"	E-Code	0x00	ETX	Bcc
-----	------	--------	-----	-------	--------	------	-----	-----

☞ Note

CHM-18XXX Series 'Secret Key'

KEY A: FFFFFFFFFF

KEY B: FFFFFFFFFF

Doc No	CHM18XXX SPECIFICATIONS	REV.	PAGE	DATE
		B	32 OF 35	2010. 12. 06.

3.3 “R53”: Select ‘Secret Key Index’

☞ Command Format

SOH	Null	Length	STX	“R53”	DATA	ETX	Bcc
-----	------	--------	-----	-------	------	-----	-----

☞ Command Data Structure

Index
0x01 – 0x02
1Byte (Hex)

☞ Positive Response Format

SOH	Null	Length	STX	“R53”	GOOD	0x01	ETX	Bcc
-----	------	--------	-----	-------	------	------	-----	-----

☞ Negative Response Format

SOH	Null	Length	STX	“R53”	E-Code	0x00	ETX	Bcc
-----	------	--------	-----	-------	--------	------	-----	-----

☞ Data Variable

<Index>

Code	Setting	Detail
0x01	KEY A	Select ‘Secret Key A’
0x02	KEY B	Select ‘Secret Key B’

☞ Note

CHM-18XXX Series ‘Secret Key Index’

‘Secret Key Index ‘: KEY A

3.4 “R54”: Change RF card ‘Secret Key’ to other key

☞ Command Format

SOH	Null	Length	STX	“R54”	DATA	ETX	Bcc
-----	------	--------	-----	-------	------	-----	-----

☞ Command Data Structure

Sector	KEY A	Access	KEY B
0x00 – 0x0f	0x00 – 0xff	0x00 – 0xff	0x00 – 0xff
1Byte (Hex)	6Byte (Hex)	4Byte (Hex)	6Byte (Hex)

☞ Positive Response Format

SOH	Null	Length	STX	“R54”	GOOD	0x01	ETX	Bcc
-----	------	--------	-----	-------	------	------	-----	-----

☞ Negative Response Format

SOH	Null	Length	STX	“R54”	E-Code	0x00	ETX	Bcc
-----	------	--------	-----	-------	--------	------	-----	-----

☞ Warning

If you use this command incorrectly, it couldn’t be authenticated from the card.

Doc No	CHM18XXX SPECIFICATIONS	REV.	PAGE	DATE
		B	33 OF 35	2010. 12. 06.

4 RF DETECT

4.1 "R61": RF card detect in antenna area

☞ Command Format

SOH	Null	Length	STX	"R61"	ETX	Bcc
-----	------	--------	-----	-------	-----	-----

☞ Positive Response Format

SOH	Null	Length	STX	"R61"	GOOD	DATA	0x01	ETX	Bcc
-----	------	--------	-----	-------	------	------	------	-----	-----

☞ Negative Response Format

SOH	Null	Length	STX	"R61"	E-Code	0x00	ETX	Bcc
-----	------	--------	-----	-------	--------	------	-----	-----

☞ Response Data Structure

Serial Number
Hex Code
4Byte

☞ Note

If the RF card is detected, send the Serial Number to host. But, it doesn't authenticate the Secret Key of the RF card.

Doc No	CHM18XXX SPECIFICATIONS	REV.	PAGE	DATE
			B	34 OF 35

ERROR DETAIL

<GOOD>

Code: 0x0000

Description: Normal Execution

Procedures: None

<NOT_DEFINE_COMMAND>

Code: 0x2001

Description: Using the command that does not defined in this model.

Action: Use the valid command in this model.

<NOT_USE_COMMAND>

Code: 0x2002

Description: Not available command in this model.

Action: Use the valid command in this model.

<COMM_FRAME_ERROR>

Code: 0x2003

Description: Sending the command that has the invalid communication frame.

Action: Check the data format and the corresponding module specification.

<CARD_JAM>

Code: 0x2004

Description: When the card is jammed.

Action: Remove the jammed card.

<NO_CARD>

Code: 0x2005

Description: No cards.

Action: Insert the card.

Doc No	CHM18XXX SPECIFICATIONS	REV.	PAGE	DATE
		B	35 OF 35	2010. 12. 06.

<CARD_PRESENT>

Code: 0x2006

Description: When the card exists already in the terminal.

Action: Eject the card.

<TWO_MORE>

Code: 0x2009

Description: When more than two cards exit in the terminal simultaneously.

Action: Remove the Card.

<ALL_EMPTY>

Code: 0x2104

Description: No cards at stacker.

Action: Load the card in the stacker.

<RF_ERROR>

Code: 0x2300

Description: Unavailable RF module.

Action: Change the RF MODULE

<RF_COMM_ERROR>

Code: 0x2301

Description: Communication error at the RF Module.

Action: Check the connection socket

<RF_AUTHEN_ERROR>

Code: 0x2302

Description: Authentication Error at the RF Module.

Action: Change the 'SECRET KEY'

<RF_WRITE_ERROR>

Code: 0x2303

Description: Error while the terminal writes at the RF Card.

Action: Be sure that the card exists in the detection range.

Doc No	CHM18XXX SPECIFICATIONS	REV.	PAGE	DATE
			B	36 OF 35

<RF_READ_ERROR>

Code: 0x2304

Description: Error while the terminal reads at the RF Card.

Action: Be sure that the card exists in the detection range.

<RF_DETECT_ERROR>

Code: 0x2305

Description: No RF Card.

Action: Insert the RF Card into the terminal.

<RF_VALUE_ERROR>

Code: 0x2306

Description: Error while the value increases (or decreases) at the RF Card.

Action: Be sure that the card exists in the detection range.