

DOC NO	CHM-1XXX CASE TYPE	REV	PAGE	DATE
8202-0024	SERVICE MANUAL	B	2 OF 57	2011. 12. 15

Notice

We greatly appreciate your using CHM-1XXX CASE TYPE series.

Please follow this manual which is helpful for user to maintain
and repair CHM-1XXX CASE TYPE series when facing problem.

If you need other assistance or just have a question,

please call our technical support staff or send us e-mail

Contents

PART-I.	Configuration of CHM-1XXX series	=====	1 ~ 2	PAGE
PART-II.	Maintenance and repair	=====	3 ~ 4	PAGE
PART-III.	Trouble shooting	=====	5 ~ 6	PAGE
PART-IV.	Parts Replacement	=====	7 ~ 49	PAGE
PART-V.	Spare part list	=====	50 ~ 56	PAGE
PART-VI	Contact information	=====	57	PAGE

DOC NO	CHM-1XXX CASE TYPE		REV	PAGE	DATE
8202-0024	SERVICE MANUAL		B	3 OF 57	2011. 12. 15
PART (1)	MAINTENANCE	PROCESS			

NO	Section	Maintenance method	
1	ROLLER CLEANING	<p>Wet CLEANING CARD with 4 ~ 7 drop of alcohol, And then wipe the header and roller with cleaning card in 5 ~ 6 times by moving the roller.</p> <p>☞ Clean every day or every week according to the pollution rate and the movement status of the roller.</p>	

DOC NO		CHM-1XXX CASE TYPE		REV	PAGE	DATE
8202-0024		SERVICE MANUAL		B	4 OF 57	2011. 12. 15
PART (1)		MAINTENANCE	PROCESS			
NO	Section	Maintenance method				
2	BELT TENSION	<p>As the picture on the right, Loosen the screws with the plus screw driver. And push up or pull down the motor along the arrows. And then tighten the screws.</p> <p>☞ it does require maintenance every week or every month according to the belt tension.</p>				
3	Parts replacement	<p>1. All assembly is in reverse order of disassembly.</p> <p>2. Please be sure to take care of "※ NOTE" mark.</p>				

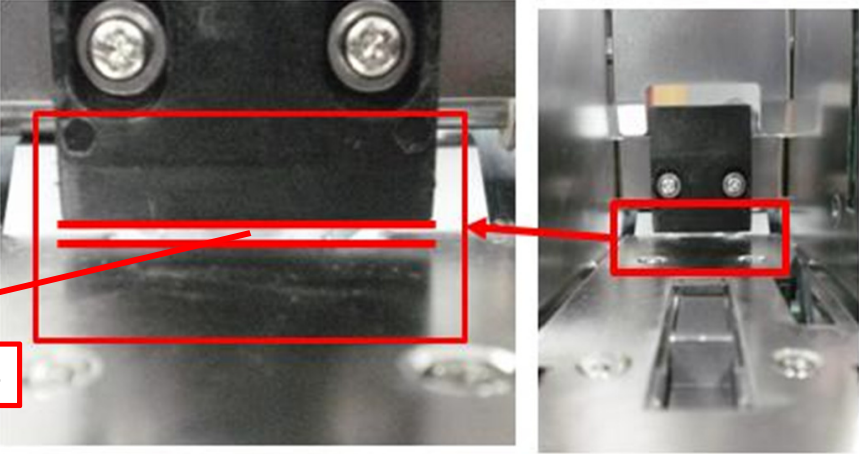
DOC NO	CHM-1XXX CASE TYPE		REV	PAGE	DATE
8202-0024	SERVICE MANUAL		B	5 OF 57	2011. 12. 15
PART (2)	TROUBLE SHOOTING	PROCESS			
NO	Malfunction	CHECK POINT	Management		
1	Communication Error	1. Check on/off status of Power switch. 2. Check if the power cable is normal. 3. Check if communication cable's connection is normal.	1. Power switch ON 2. Power cable connect 3. Communication cable connect		
2	Card feeding error or Card jam	1. Inspect connection status of the cables (Motor and sensor) 2. Sensor is functioning normally. (Insert the card into the front entrance, and then check if the sensor voltage is changed from HI (4.6v over) to LOW (0.5v under) while you turn the main pulley by hand.) 3. Check if the motor is functioning normally (Supply DC 24V to the motor.) 4. Confirm main PCB' A 5. Check the pollution rate of sensor and roller. 6. Confirm the belt tension. 7. Check if roller gap is appropriate.	1. Motor & Sensor cable connect 2. Replace SENSOR PCB'A. 3. Replace Motor. 4. Replace Main PCB'A. 5. Remove the dust and clean the roller. 6. Adjust or replace the belt tension. 7. Loosen the screw of the stopper a little. And insert the card with paper or gap gauge between stopper and ass'y middle shaft. And then push up middle of the stopper and tighten the SCREW while maintaining level of the stopper. (CARD GAP: CARD thickness * 1.2 ~ 1.4) - (See Picture) 8. Load the cards in the cartridge normally.		
					
		<div style="border: 1px solid red; padding: 5px; display: inline-block;"> GAP : CARD THICKNESS * 1.2 or 1.4 </div>			

DOC NO	CHM-1XXX CASE TYPE SERVICE MANUAL	REV	PAGE	DATE
8202-0024		B	6 OF 57	2011. 12. 15

PART (III)	TROUBLE SHOOTING	PROCESS
-------------------	-------------------------	----------------

NO	Malfunction	CHECK POINT	Management
3	READ/WRITE ERROR	1. Check HEAD's life time. 2. Check HEAD's gap. 3. Check HEAD's pollution rate. 4. Check the cards to use. 5. Check MAIN PCBA.	1. Replace HEAD 2. Adjust HEAD's gap with the SET SCREW to $0.2\text{mm} \pm 0.1\text{mm}$ as the picture below. (Adjust the gap of "A" and "B" the same. And if 0.2T cards is used, adjust to $0 \sim 0.15\text{mm}$.) 3. Clean the HEAD. 4. 1) Check the pollution rate (Card cleaning) 2) Check the card with another card reader. 5. Replace MAIN PCBA

HEAD GAP SETTING

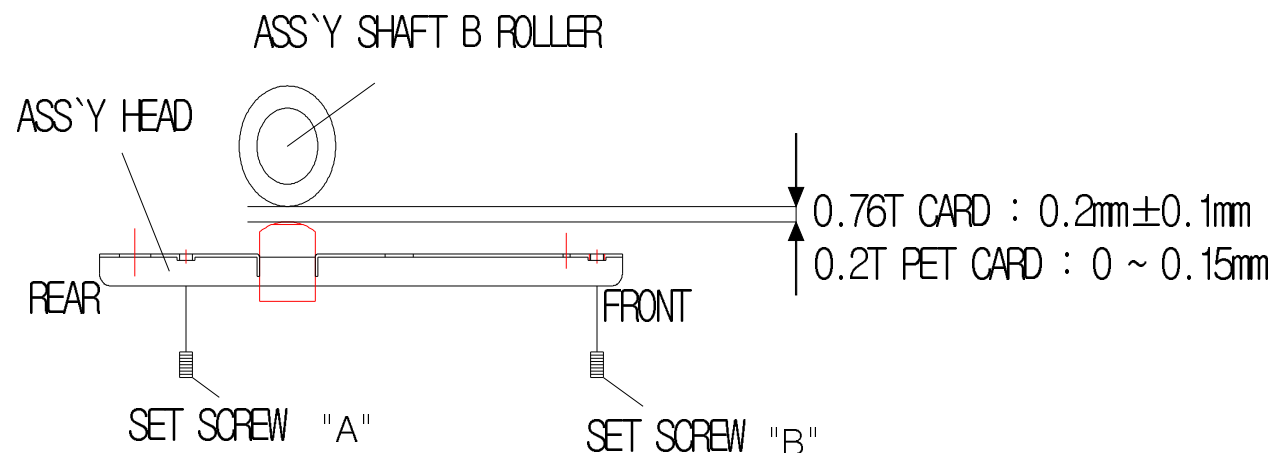

DOC NO	CHM-1XXX CASE TYPE SERVICE MANUAL	REV	PAGE	DATE
8202-0024		B	7 OF 57	2011. 12. 15
PART (3)	DISASSEMBLE & CHANGE	PROCESS	CAPTURE BOX Disassembly	

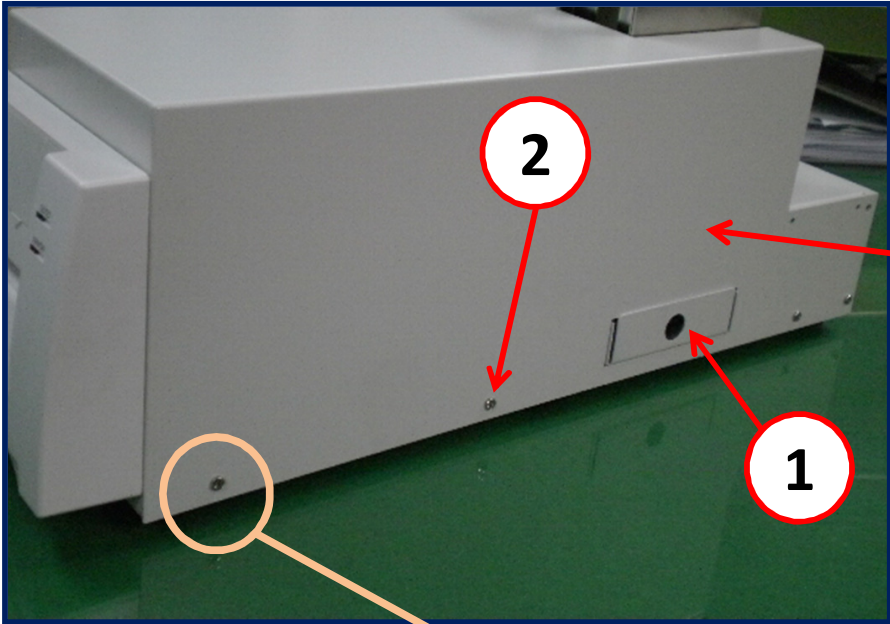

NO	PART NO	REV	PATR NAME / SPEC	Q'TY
1	69030110-00	A	CAPTURE BOX	1
2	60810001-00	A	SCREW BH M3*4L FNW	4
3	67020015-00	A	COVER CASE	1

● Sequence

1. Pull out CAPTURE BOX(1).
2. Unscrew SCREW(2). [The same working is the other side.]
3. Disassemble CASE COVER.

TOOL	+ SCREW DRIVER
------	----------------

DOC NO	CHM-1XXX CASE TYPE SERVICE MANUAL	REV	PAGE	DATE
8202-0024		B	8 OF 57	2011. 12. 15
PART (3)	DISASSEMBLE & CHANGE	PROCESS	ASS'Y BEZEL COVER Disassembly	

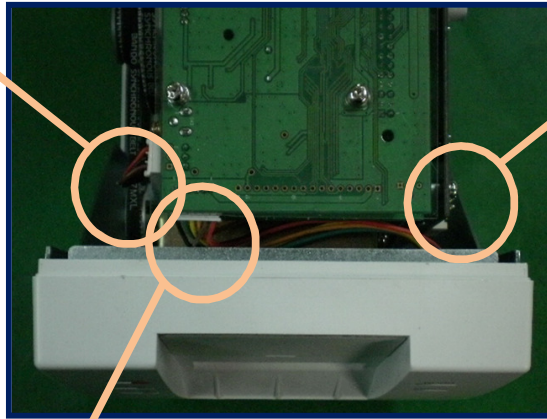
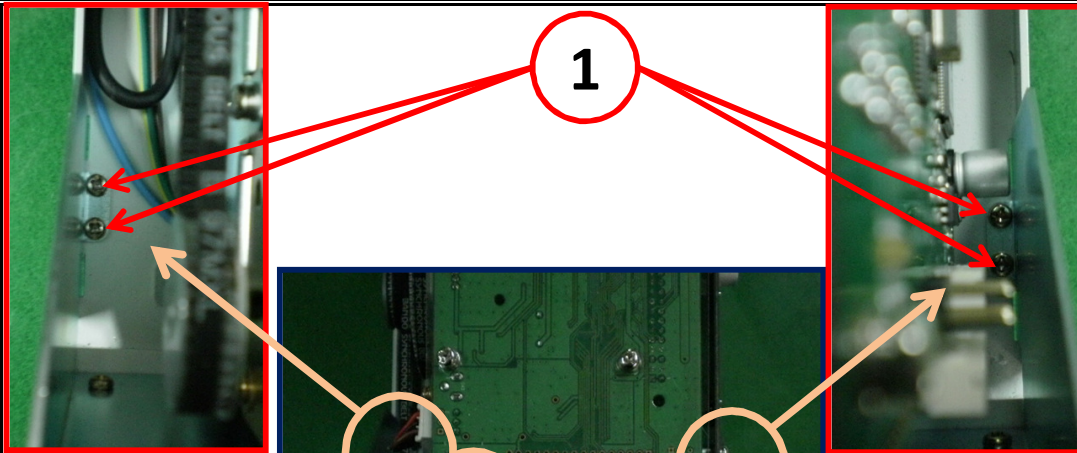

NO	PART NO	REV	PATR NAME / SPEC	Q'TY
1	60117030-00	A	SCREW PH M3*3 FZY	4

● Sequence
 1. Pull out cable.
 2. Unscrew SCREW(1), and then disassemble ASS'Y BEZEL COVER.

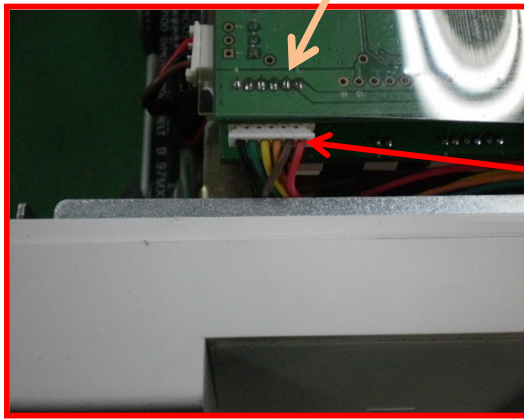

**89266606-00
 ASS'Y HARNESS LED : 6P *250mm**

TOOL	+ SCREW DRIVER
------	----------------

DOC NO	CHM-1XXX CASE TYPE SERVICE MANUAL	REV	PAGE	DATE
8202-0024		B	9 OF 57	2011. 12. 15
PART (3)	DISASSEMBLE & CHANGE	PROCESS	ASS'Y PCB COVER Disassembly	

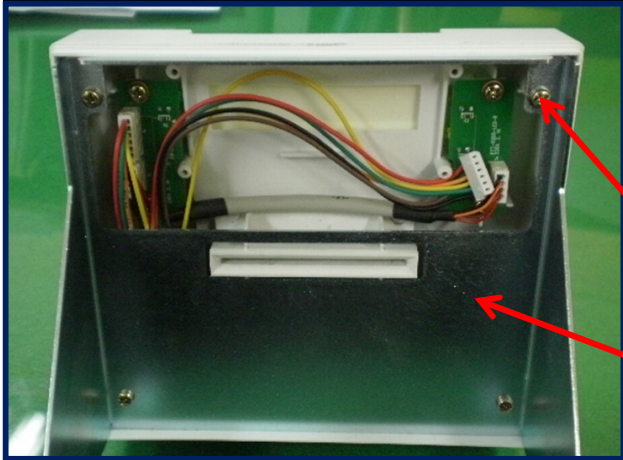

2

1

89266606-00
ASS'Y HARNESS LED : 6P *250mm

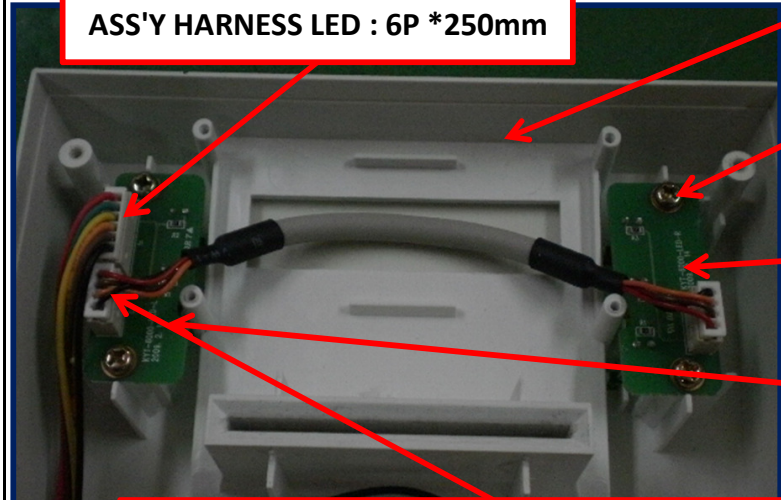

3

6

4

5

89266607-00
ASS'Y HARNESS LED PCB CONNECT : 4P *130mm

NO	PART NO	REV	PATR NAME / SPEC	Q'TY
1	69030111-00	A	FRONT BEZEL BRACKET	1
2	60617060-00	A	SCREW TH M3*6 FZY	4
3	67040016-00	A	FRONT BEZEL	1
4	89280244-00	A	LED-R PCB	1
5	89280243-00	A	LED_L PCB	1
6	60617060-00	A	SCREW TH M3*6 FZY	4

● Sequence

1. Unscrew SCREW(2), and then disassemble FRONT BEZEL BRACKET(1).
2. Unscrew SCREW(6), and then disassemble LED PCB(4)(5).

TOOL	+ SCREW DRIVER
------	----------------

DOC NO	CHM-1XXX CASE TYPE SERVICE MANUAL	REV	PAGE	DATE
8202-0024		B	10 OF 57	2011. 12. 15
PART (3)	DISASSEMBLE & CHANGE	PROCESS	ASS'Y MAIN PCB Disassembly	

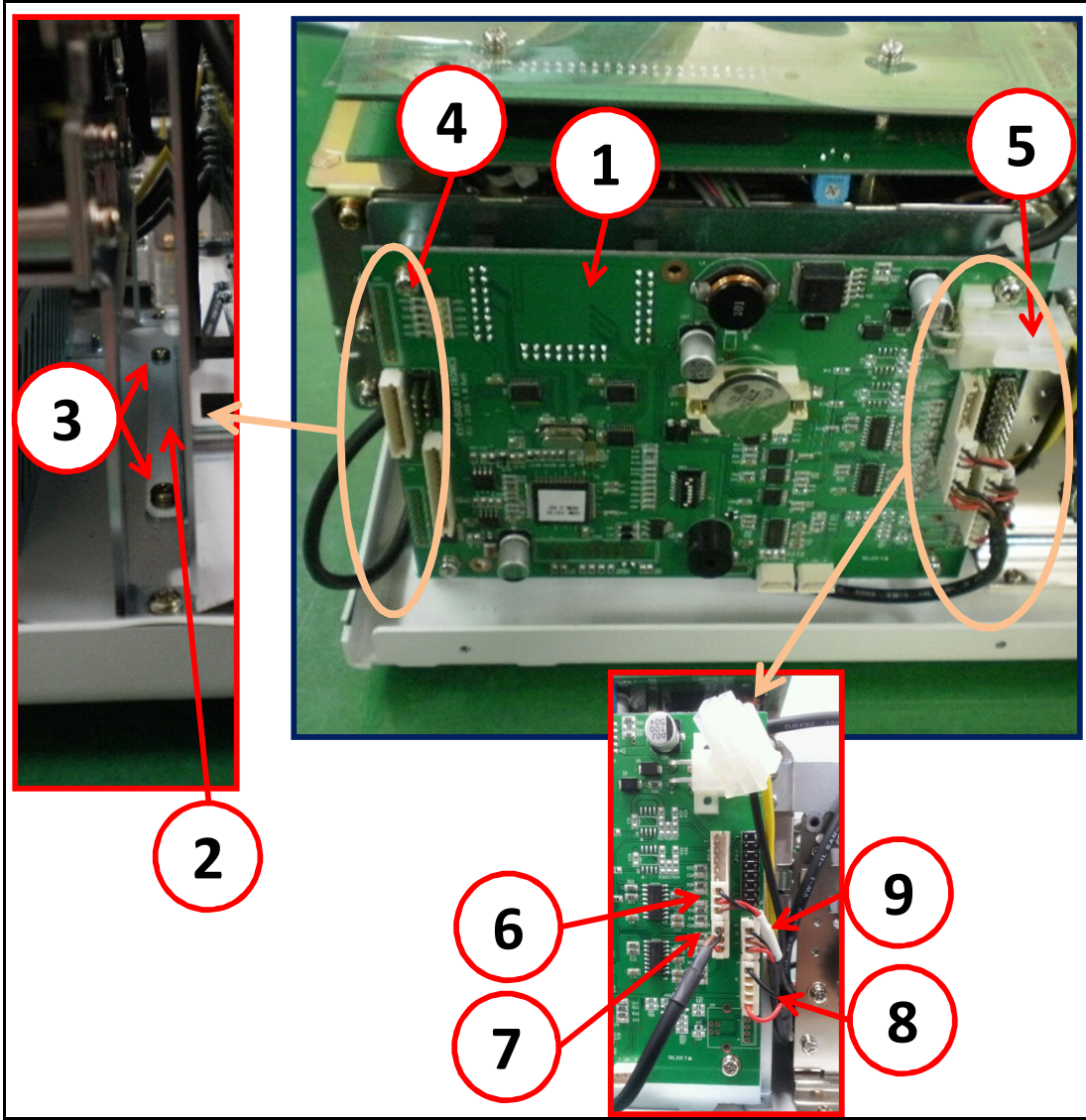

NO	PART NO	REV	PATR NAME / SPEC	Q'TY
1	89205002-00	A	MAIN CONTROL PCB	1
2	69030112-00	A	MAIN PCB BRKT	1
3	60117030-00	A	SCREW PH M3*3 FZY	2
4	60917063-00	A	SCREW PH M3*6 FNW (SEMS SMALL)	4
5	89268013-00	A	POWER CABLE (DISPENSER, MAIN)	1
6	89268073-00	A	ASS'Y COM CABLE(MAIN TO SUB BOARD)	1
7	89268015-00	A	ASS'Y COM CABLE(KYT-3000 to MAIN)	1
8	49090001-00	A	FAN	1
9	89268008-00	A	ASS'Y COM CABLE(DISPENSER)	1

- Sequence
1. Pull out all cables.
 2. Unscrew SCREW(4), and then disassemble MAIN PCB(1).
 3. Unscrew SCREW(3), and then disassemble BRKT(2).

TOOL	+ SCREW DRIVER
------	----------------

DOC NO	CHM-1XXX CASE TYPE SERVICE MANUAL	REV	PAGE	DATE
8202-0024		B	11 OF 57	2011. 12. 15
PART (3)	DISASSEMBLE & CHANGE	PROCESS	ASS'Y READ/WRITER Disassembly	

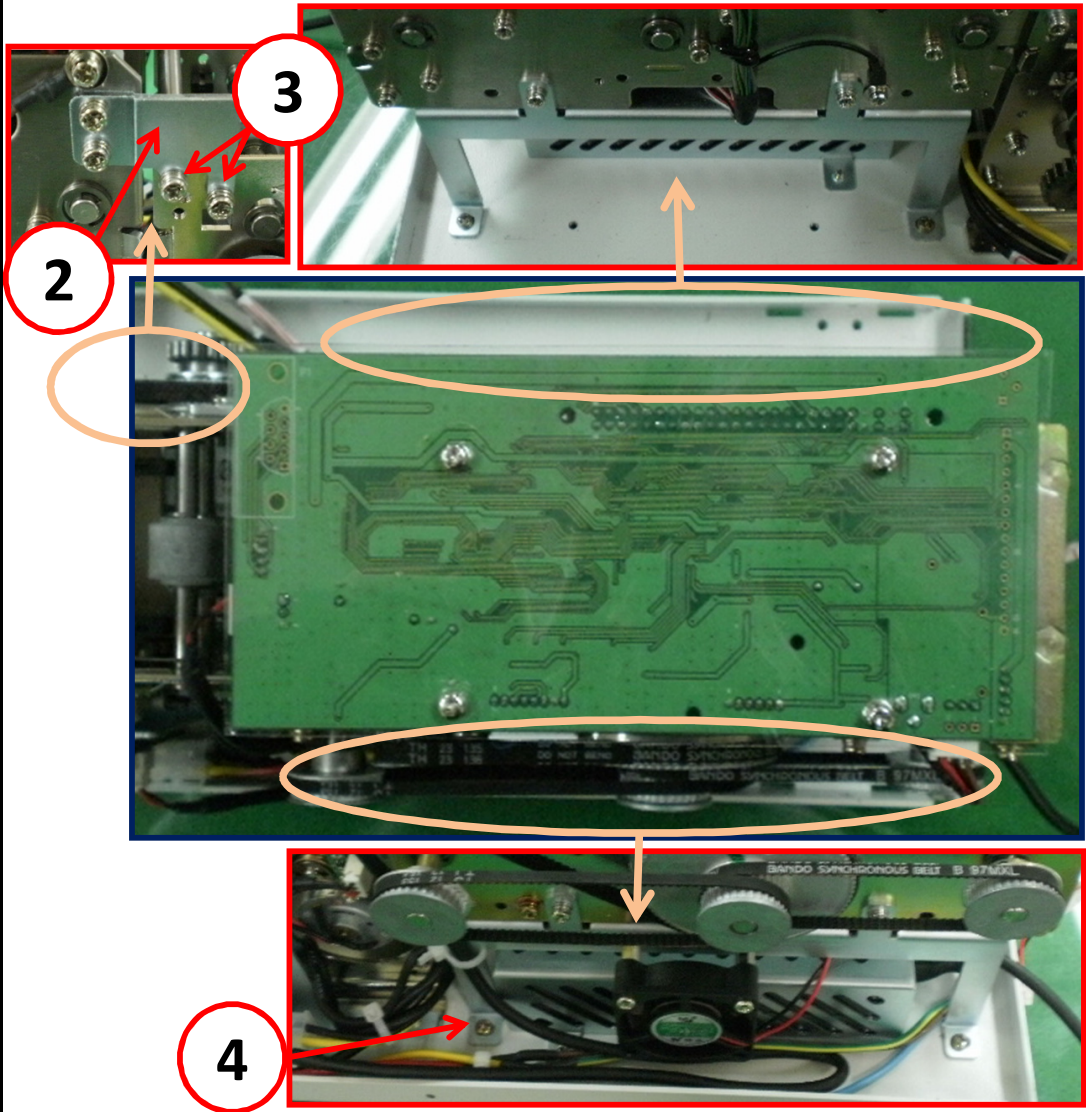

NO	PART NO	REV	PATR NAME / SPEC	Q'TY
1	69030114-00	A	MOUNT BRKT	1
2	60917063-00	A	SCREW PH M3*6 FNW (SEMS SMALL)	2
3	60817033-00	A	SCREW BH M3*3 FNW	4

● Sequence

1. Unscrew SCREW(2), and then disassemble MOUNT BRKT(1).
2. Unscrew SCREW(3), and then ASS'Y READ/WRITER.

TOOL	+ SCREW DRIVER
------	----------------

DOC NO	CHM-1XXX CASE TYPE SERVICE MANUAL	REV	PAGE	DATE
8202-0024		B	12 OF 57	2011. 12. 15
PART (3)	DISASSEMBLE & CHANGE	PROCESS	FAN, MARW BASE BRKT Disassembly	

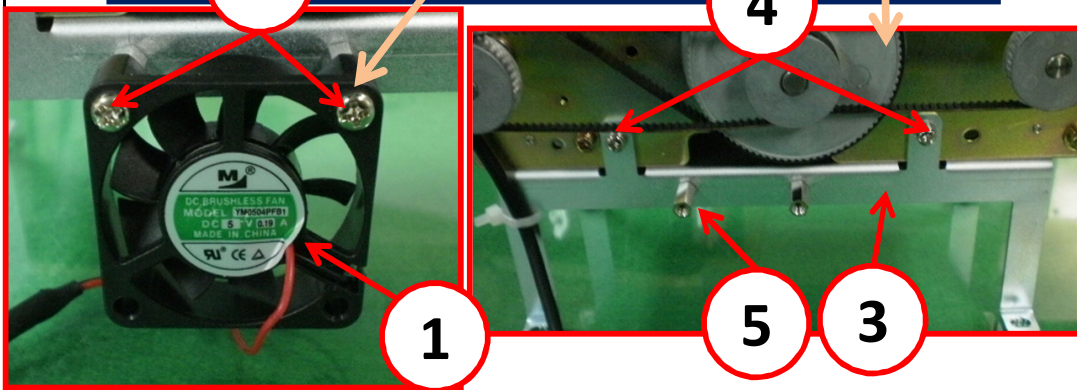
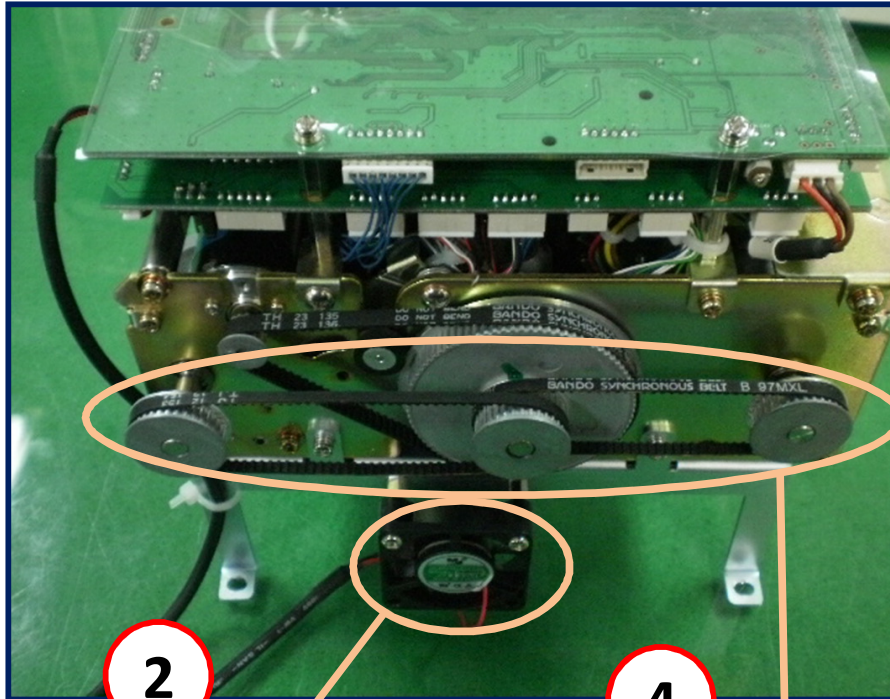

NO	PART NO	REV	PATR NAME / SPEC	Q'TY
1	49090001-00	A	FAN	1
2	60910004-00	A	SCREW M3*10.2 SUS 303	2
3	69030115-00	A	MSRW BASE BRKT	1
4	60917063-00	A	SCREW PH M3*6 FNW (SEMS SMALL)	4
5	72330004-00	A	POST NUT M3*12L	2

- Sequence
1. Unscrew SCREW(2), and then disassemble FAN(1).
 2. Unscrew SCREW(4), and then disassemble BASE BRKT(3).
 3. Unscrew POST NUT(5).

TOOL	+ SCREW DRIVER
------	----------------

DOC NO	CHM-1XXX CASE TYPE SERVICE MANUAL	REV	PAGE	DATE
8202-0024		B	13 OF 57	2011. 12. 15
PART (3)	DISASSEMBLE & CHANGE	PROCESS	ASS'Y PCB COVER & MAIN PCB Disassembly	

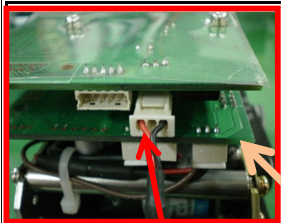

**89260009-00
POWER CABLE
(2 PIN * 450mm)**

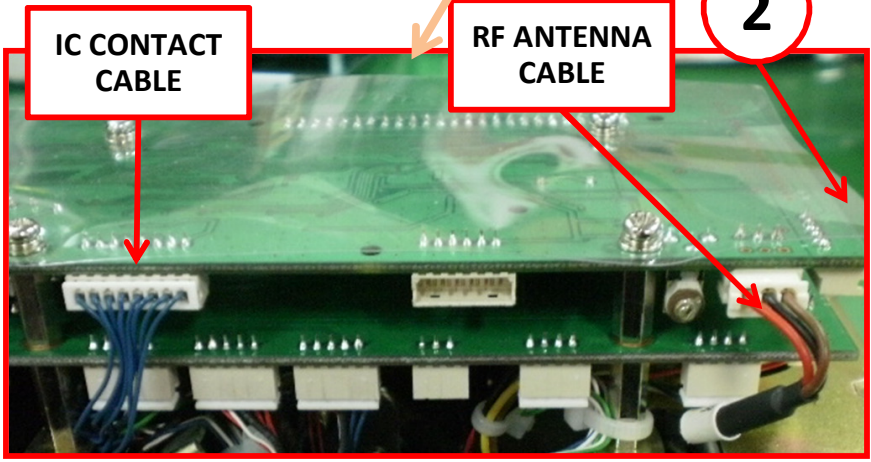
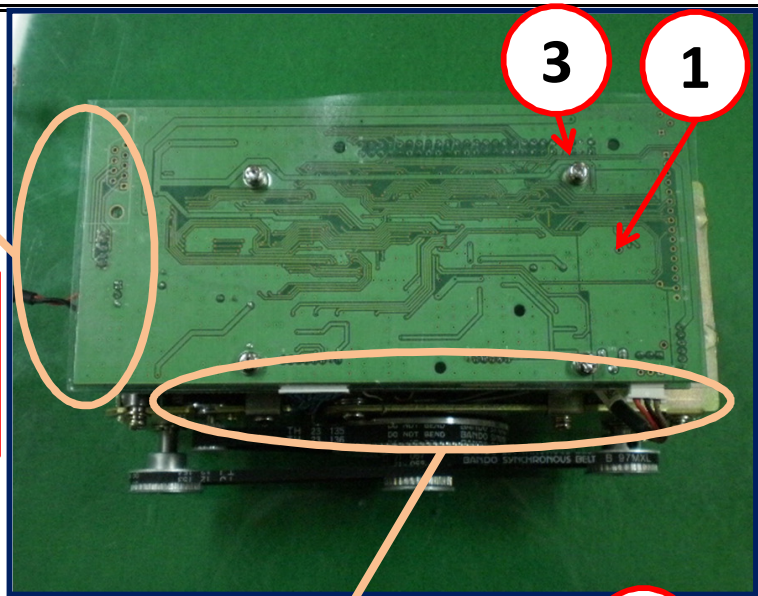

**IC CONTACT
CABLE**

**RF ANTENNA
CABLE**

NO	PART NO	REV	PATR NAME / SPEC	Q'TY
1	89520223-00	B	ASS'Y MAIN PCB - RS232C	1
2	78930002-00	A	PCB COVER	1
3	69017061-00	A	SCREW M3*6 PH FNW (SEMS SMALL)	4

● Sequence
 1. Pull out all cables.
 2. Unscrew SCREW(3), and then disassemble PCB COVER(2), MAIN PCB(1).

TOOL	+ SCREW DRIVER
------	----------------

DOC NO	CHM-1XXX CASE TYPE SERVICE MANUAL	REV	PAGE	DATE
8202-0024		B	14 OF 57	2011. 12. 15
PART (3)	DISASSEMBLE & CHANGE	PROCESS	ASS'Y CABLE connection position	

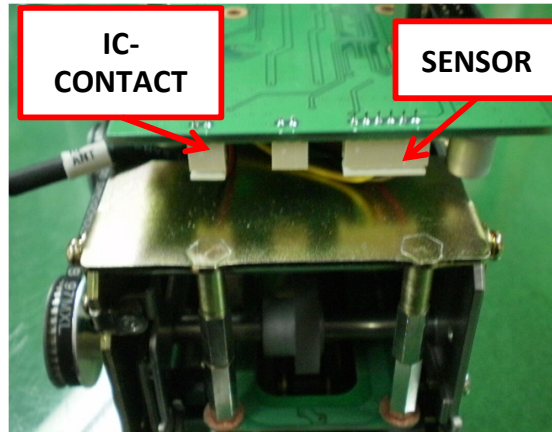
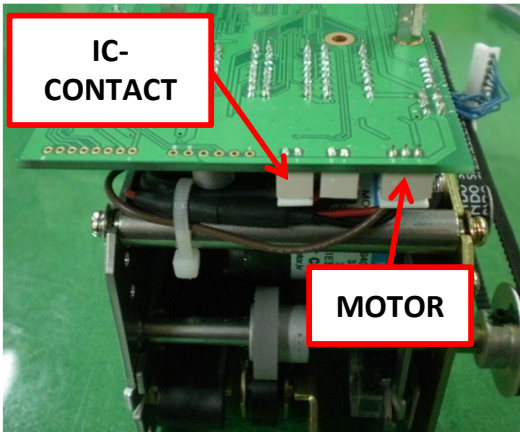
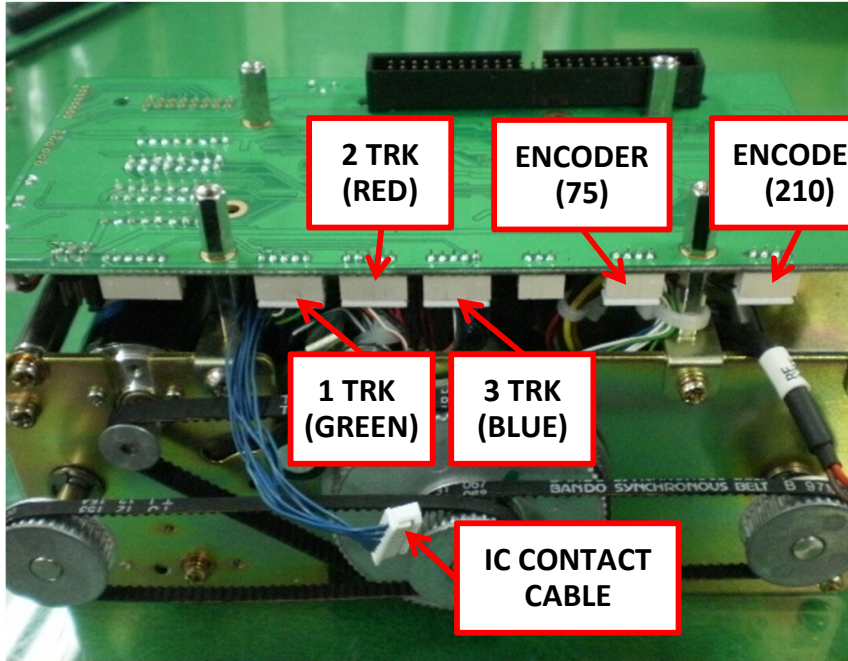

NO	PART NO	REV	PATR NAME / SPEC	Q'TY

- Sequence
- 1. Pull out all cables.

TOOL	
------	--

DOC NO	CHM-1XXX CASE TYPE SERVICE MANUAL	REV	PAGE	DATE
8202-0024		B	15 OF 57	2011. 12. 15
PART (3)	DISASSEMBLE & CHANGE	PROCESS	ASS'Y TTL PCB Disassembly	

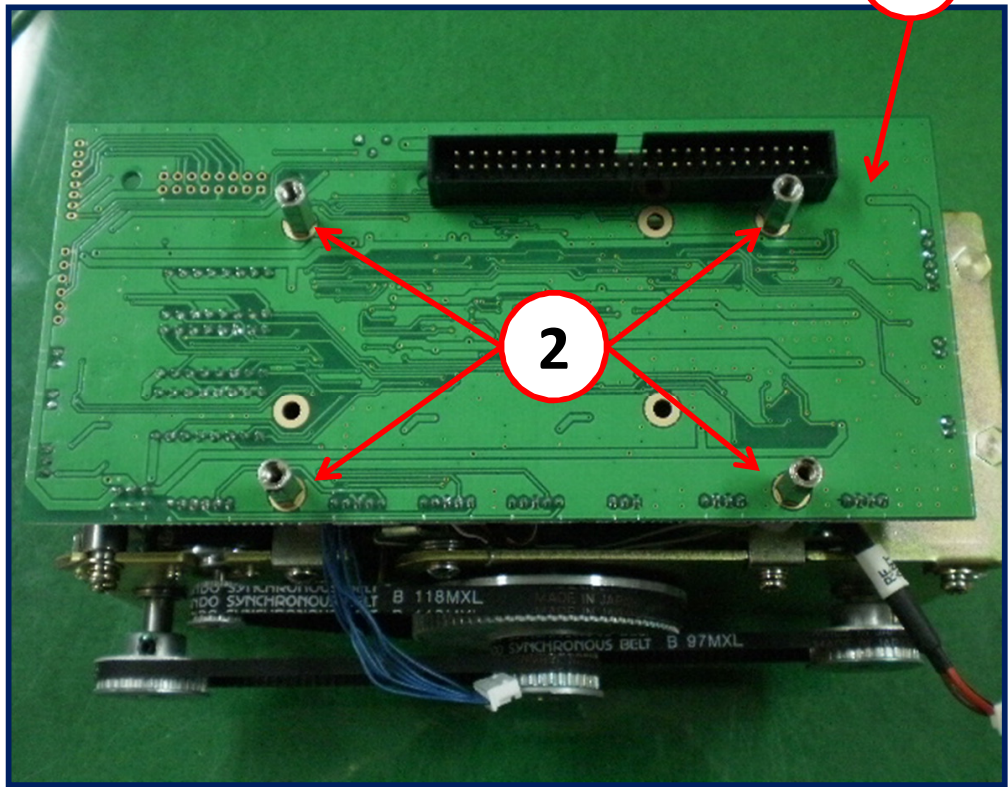

NO	PART NO	REV	PATR NAME / SPEC	Q'TY
1	89270218-00	B	ASS'Y TTL PCB	1
2	72330004-00	A	POST NUT M3*12	4

● Sequence
 1. Unscrew POST NUT(2), and then disassemble ASS'Y TTL PCB(1).

TOOL	+ SCREW DRIVER , 5mm HEX NUT DRIVER
------	-------------------------------------

DOC NO	CHM-1XXX CASE TYPE SERVICE MANUAL	REV	PAGE	DATE
8202-0024		B	16 OF 57	2011. 12. 15
PART (3)	DISASSEMBLE & CHANGE	PROCESS	ASS'Y PCB MOUNTER Disassembly	

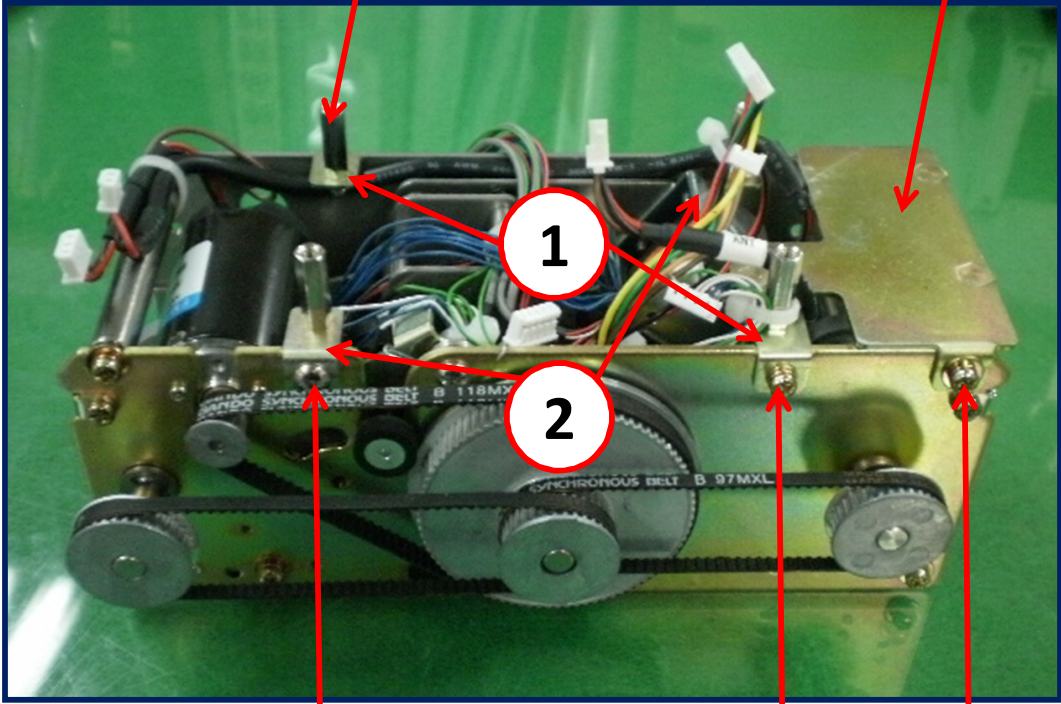

NO	PART NO	REV	PATR NAME / SPEC	Q'TY
1	69030008-00	A	PCB MOUNTER-A	2
2	69030009-00	A	PCB MOUNTER-B	2
3	72230005-00	A	POST NUT M3*15	4
4	60617063-00	A	SCREW M3*6 TH FNW	1
5	60917061-00	A	SCREW M3*6 PH FZY (SEMS SMALL)	3
6	70020046-00	A	ANT BRKT	1
7	60917060-00	A	SCREW M3*6 PH FZY (SEMS)	2

- Sequence
1. Unscrew SCREW(4)(5), and then disassemble PCB MOUNTER-B(2), PCB MOUNTER-A(1).
 2. Unscrew SCREW(7), and then disassemble ANT BRKT(6).

TOOL	+ SCREW DRIVER
------	----------------

DOC NO	CHM-1XXX CASE TYPE SERVICE MANUAL	REV	PAGE	DATE
8202-0024		B	17 OF 57	2011. 12. 15
PART (3)	DISASSEMBLE & CHANGE	PROCESS	ASS'Y PCB COVER Disassembly	

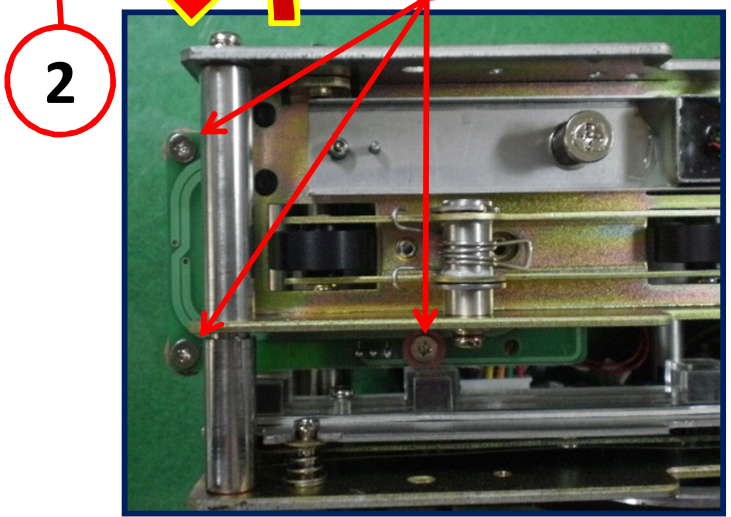
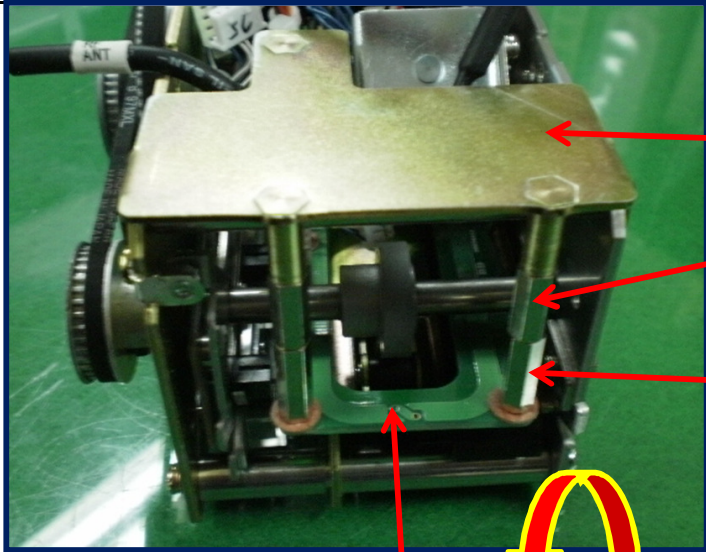

NO	PART NO	REV	PATR NAME / SPEC	Q'TY
1	70020046-00	A	ANT BRKT	1
2	89203050-00	A	ASS'Y ANT PCB	1
3	72330004-00	A	POST NUT M3*12L	2
4	72330005-00	A	POST NUT M3*15L	2
5	60927063-00	A	SCREW CONTACT M3*5 FNW	3

- Sequence
1. Unscrew SCREW(5), and disassemble ASS'Y ANT PCB(2) and ANT BRKT(1).
 2. UNSCREW POST NUT (3)(4).

TOOL	+ SCREW DRIVER, 5mm HEX NUT DRIVER
------	------------------------------------

DOC NO	CHM-1XXX CASE TYPE SERVICE MANUAL	REV	PAGE	DATE
8202-0024		B	18 OF 57	2011. 12. 15
PART (3)	DISASSEMBLE & CHANGE	PROCESS	ASS'Y IC-CONTACT & ASS'Y HEAD BRKT Disassembly	

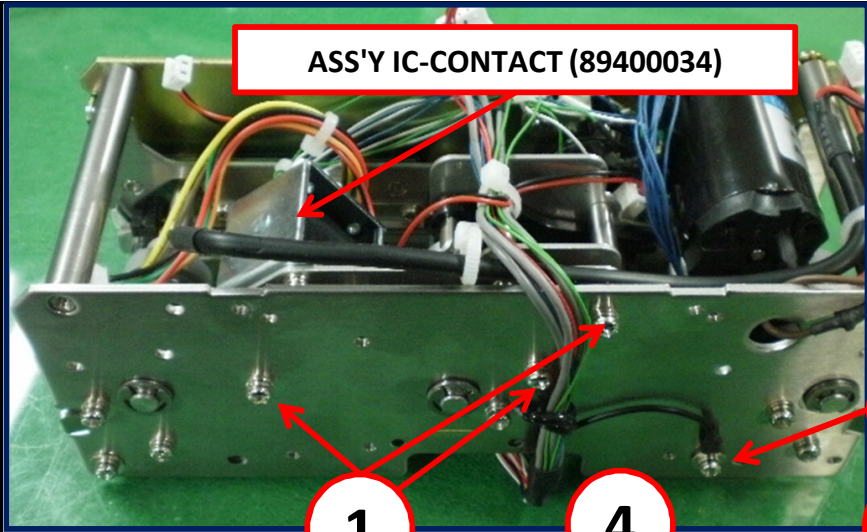

ASS'Y IC-CONTACT (89400034)

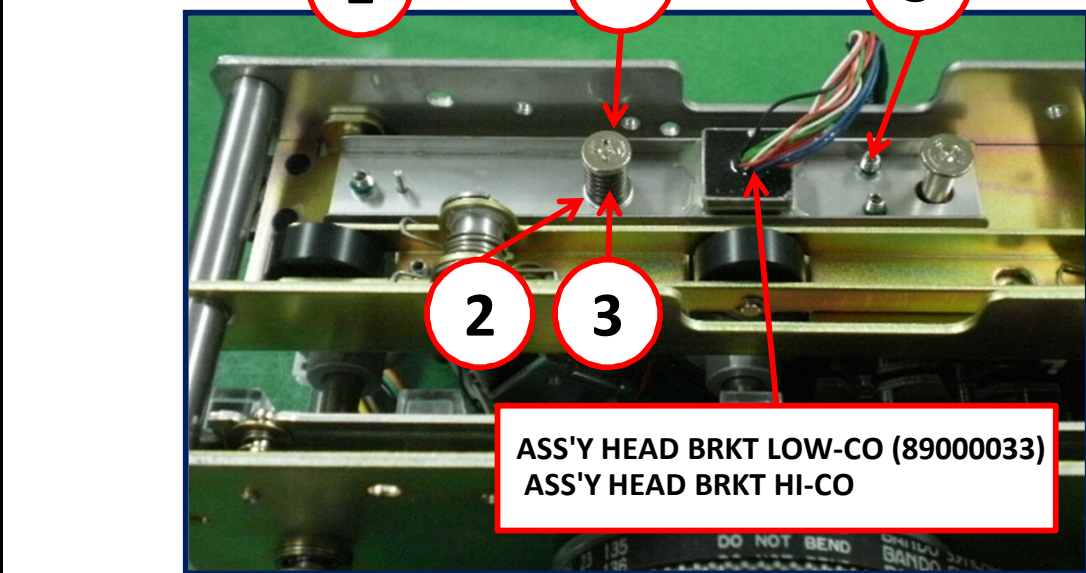

**ASS'Y HEAD BRKT LOW-CO (89000033)
ASS'Y HEAD BRKT HI-CO**

NO	PART NO	REV	PATR NAME / SPEC	Q'TY
1	60917063-00	A	SCREW M3*6 PH FNW (SEMS SMALL)	3
2	63090001-00	A	HEAD SCREW WASHER	1
3	76200005-00	A	HEAD SPRING	1
4	60910001-00	A	HEAD SCREW	2
5	62943069-00	A	SET SCREW M3*6 NYLOK	3
6	60917062-00	A	SCREW M3*6 PH FNW (SEMS)	1

● Sequence
 1. Unscrew SCREW(1), and then disassemble ASS'Y IC-CONTACT.
 2. Unscrew HEAD SCREW(4) and SCREW(6), and disassemble parts (2) (3) and then disassemble ASS'Y HEAD.

NOTE
 - When assembling ASS'Y HEAD BRKT, assemble with WASHER (2).

TOOL	+ SCREW DRIVER , 1.5mm WRENCH
------	-------------------------------

DOC NO	CHM-1XXX CASE TYPE SERVICE MANUAL	REV	PAGE	DATE
8202-0024		B	19 OF 57	2011. 12. 15
PART (3)	DISASSEMBLE & CHANGE	PROCESS	BELT & PULLEY Disassembly	

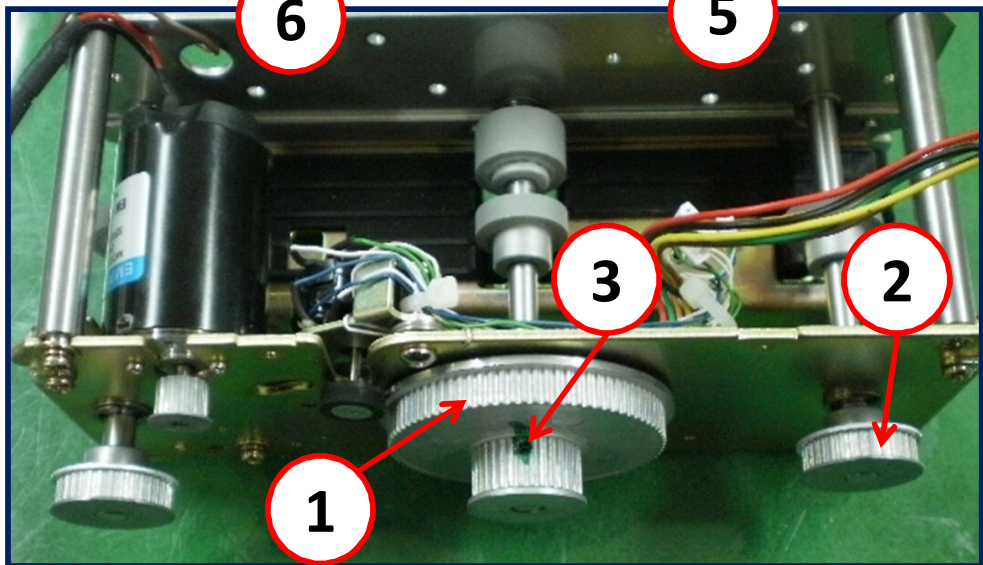
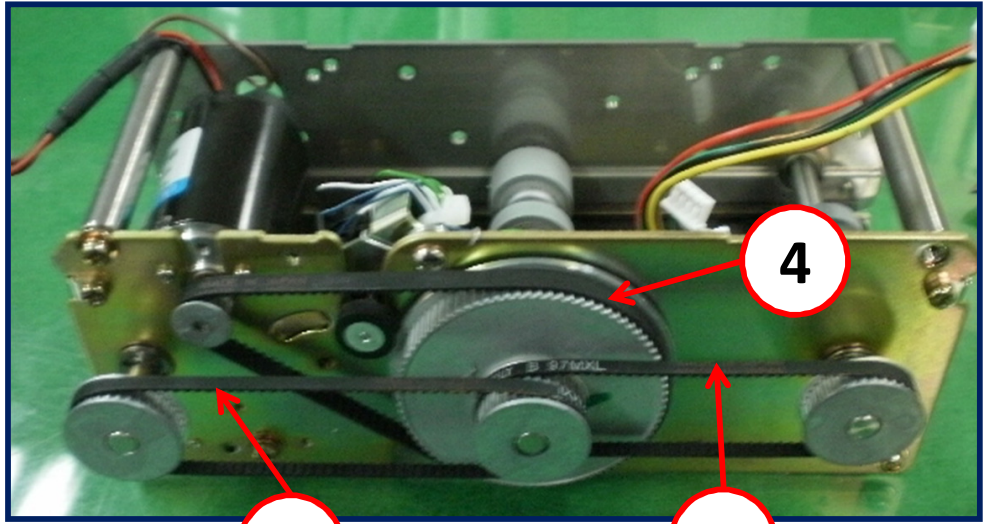

NO	PART NO	REV	PATR NAME / SPEC	Q'TY
1	74210009-00	A	MAIN PULLEY	1
2	74210008-00	A	FEEDING PULLEY	2
3	62911049-00	A	SET SCREW M3*4 SUS	3
4	74250016-00	A	BELT (118 MXL TIMING BELT)	1
5	74250014-00	A	BELT (97 MXL TIMING BELT)	1
6	74250015-00	A	BELT (112 MXL TIMING BELT)	1

- Sequence
- Strip BELT (4)(5)(6) in order.
 - Unscrew SET SCREW(3) with the hex wrench.
And disassemble MAIN PULLEY(1) and FEEDING PULLEY(2).

TOOL	+ SCREW DRIVER , 1.5mm WRENCH
------	-------------------------------

DOC NO	CHM-1XXX CASE TYPE SERVICE MANUAL	REV	PAGE	DATE
8202-0024		B	20 OF 57	2011. 12. 15
PART (3)	DISASSEMBLE & CHANGE	PROCESS	ASS'Y FRAME-R Disassembly	

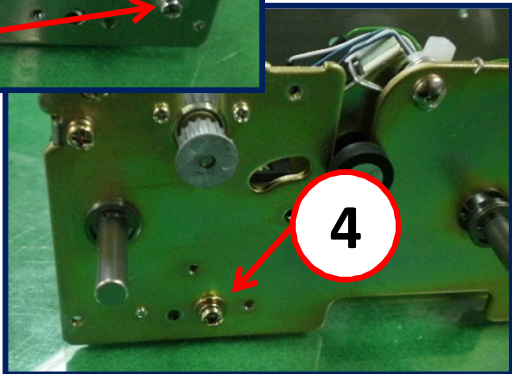
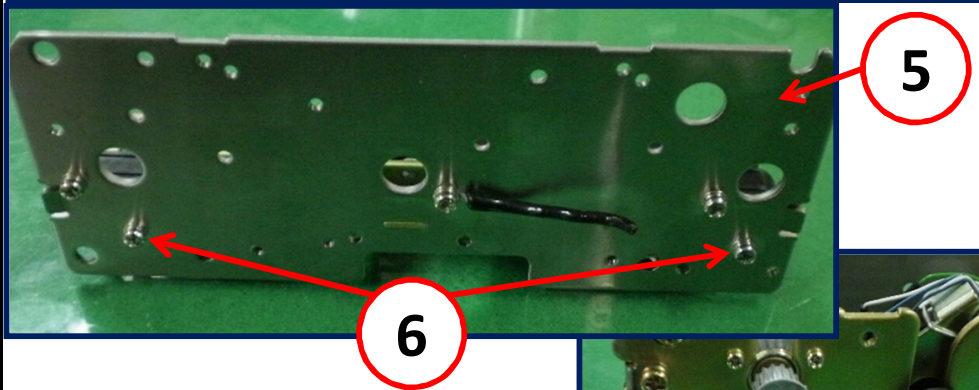
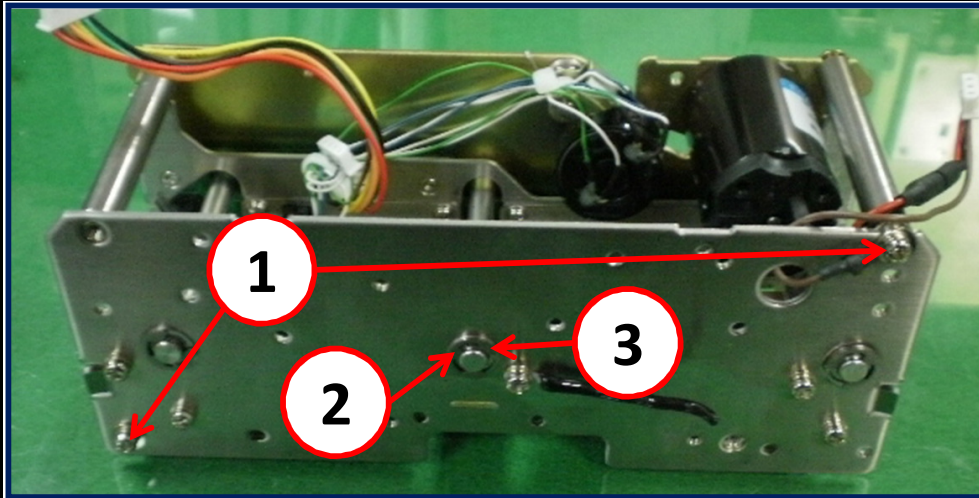

NO	PART NO	REV	PATR NAME / SPEC	Q'TY
1	60917062-00	A	SCREW M3*6 PH FNW (SEMS)	3
2	76210014-00	A	E-RING PI 5	3
3	70300004-00	A	BALL BEARING (MF 1060)	3
4	60917060-00	A	SCREW M3*6 PH FZY (SMES)	1
5	69010036-00	A	FRAME-R	1
6	60917063-00	A	SCREW M3*6 PH FNW (SEMS SMALL)	2

- Sequence
- 1. Remove SCREW(1)(4) and E-ring(2). And disassemble BEARING(3).
- 2. Unscrew SCREW(6), and then disassemble FRAME-R(6).

TOOL	+ SCREW DRIVER , PINCETTE PI 5 E-RING TOOL.
------	--

DOC NO	CHM-1XXX CASE TYPE SERVICE MANUAL	REV	PAGE	DATE
8202-0024		B	21 OF 57	2011. 12. 15
PART (3)	DISASSEMBLE & CHANGE	PROCESS	ASS'Y CARD BASE Disassembly	

89140007-00
ASS'Y CARD BASE BRKT

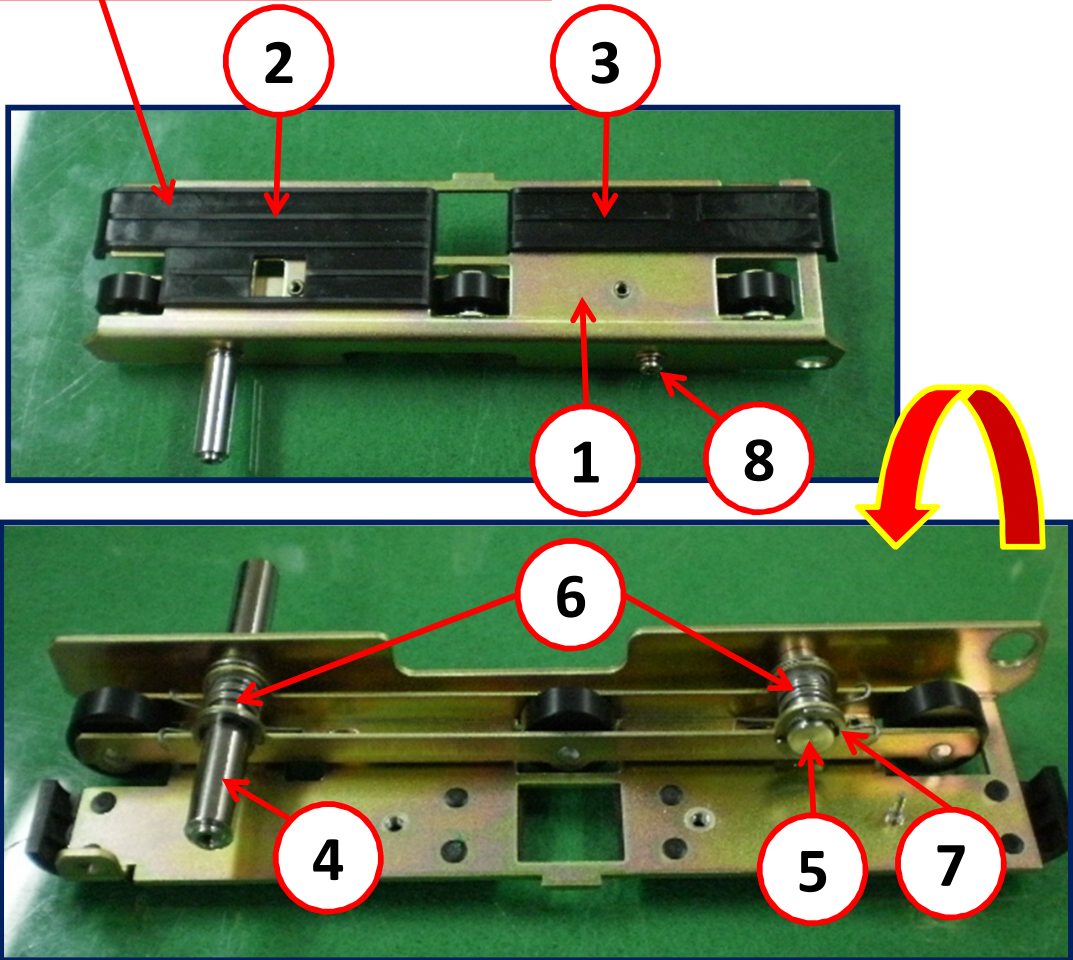

NO	PART NO	REV	PATR NAME / SPEC	Q'TY
1	70000031-00	C	CARD BASE BRKT	1
2	70010019-00	A	CARD BASE-B	1
3	70010018-00	A	CARD BASE-A	1
4	70220039-00	A	SPACER-C	1
5	70220044-00	A	IDLER BRKT PIN	1
6	76200023-00	A	IDLER BRKT SPRING	2
7	76210015-00	A	E-RING PI 6	4
8	60917060-00	A	SCREW M3*6 PH FZY (SEMS)	1

● Sequence
 1. Unscrew SCREW(8) and E-RING(7).
 And disassemble IDLER BRKT PIN(5) and SPACER-C(4).
 And then disassemble SPRING(6) from CARD BASE BRKT(1).

NOTE
 - Be sure not to disassemble CARD BASE-B(2) and CARD BASE-A(3).

TOOL	+ SCREW DRIVER , PINCETTE PI 6.0 E-RING TOOL.
------	--

DOC NO	CHM-1XXX CASE TYPE SERVICE MANUAL	REV	PAGE	DATE
8202-0024		B	22 OF 57	2011. 12. 15
PART (3)	DISASSEMBLE & CHANGE	PROCESS	ASS'Y IDLER BRKT Disassembly	

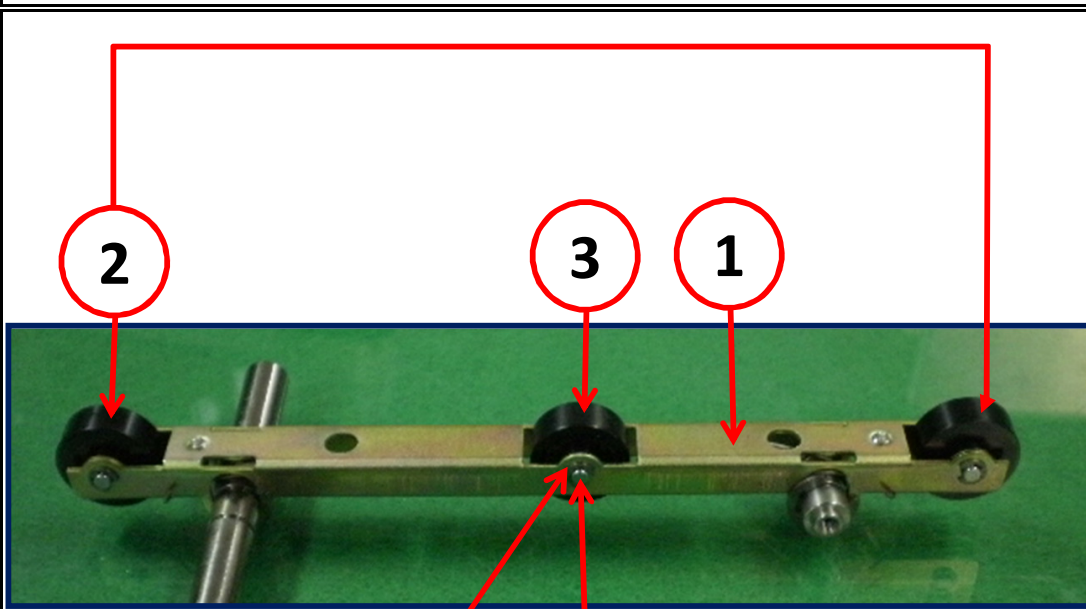

NO	PART NO	REV	PATR NAME / SPEC	Q'TY
1	70000032-00	B	IDLER BRKT	1
2	74120025-00	A	IDLER ROLLER	2
3	74120022-00	B	IDLER ROLLER PH2	1
4	70230033-00	A	IDLER ROLLER PIN	3
5	76210012-00	A	E-RING PI 3	3

● Sequence

1. Remove E-RING(5) with the tool.
And disassemble ROLLER(2)(3) and IDLER ROLLER PIN(4) from IDLER BRKT(1).

NOTE

- When assembling ROLLER(2)(3), be careful not to mix up between IDLER ROLLER(2) and IDLER ROLLER PH2(3).

TOOL	1.5 WRENCH DRIVER , PINCETTE PI 3 E-RING TOOL.
------	---

DOC NO	CHM-1XXX CASE TYPE SERVICE MANUAL	REV	PAGE	DATE
8202-0024		B	23 OF 57	2011. 12. 15
PART (3)	DISASSEMBLE & CHANGE	PROCESS	ASS'Y SHAFT A,B,C Disassembly	

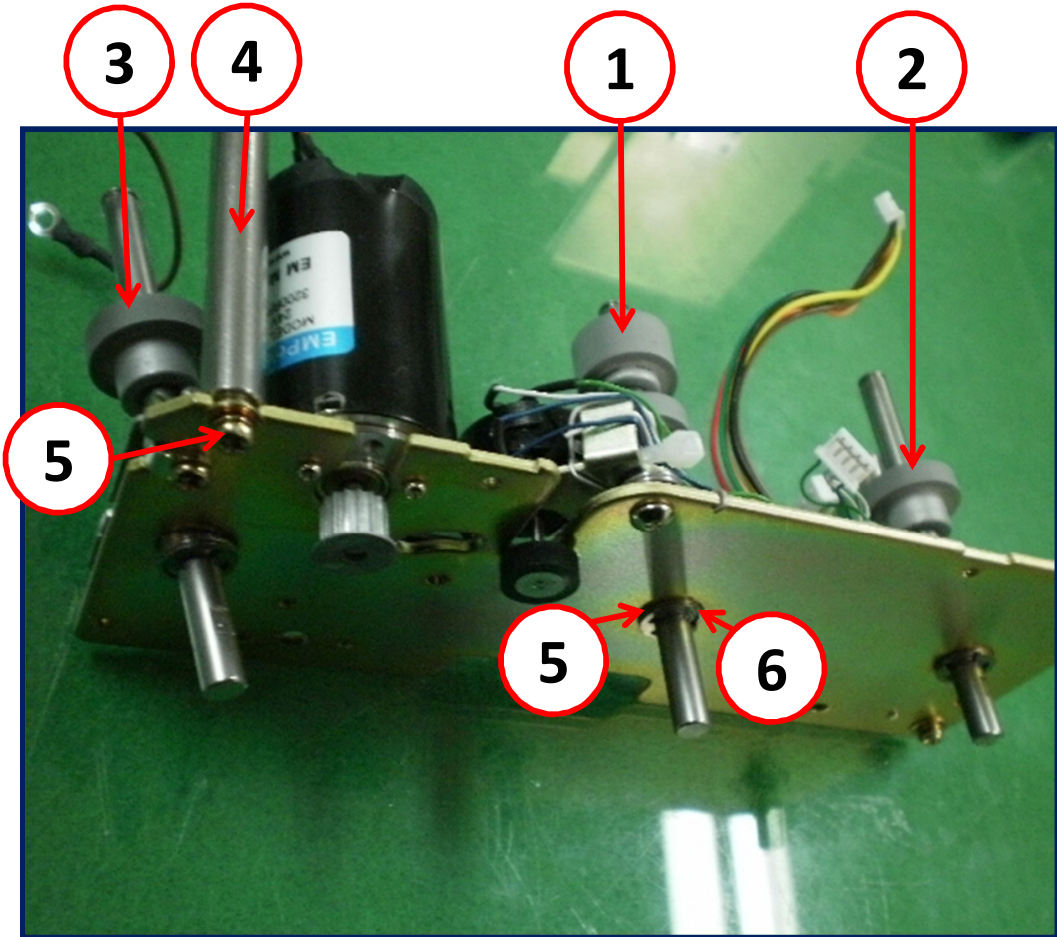

NO	PART NO	REV	PATR NAME / SPEC	Q'TY
1	89100079-00	A	ASS'Y SHAFT-C	1
2	89100078-00	A	ASS'Y SHAFT-B	2
3	89100077-00	A	ASS'Y SHAFT-A	1
4	70220037-00	A	SPACER-A	1
5	70300004-00	A	BALL BEARING (MF1060ZZ)	3
6	76210014-00	A	E-RING PI 5	3
7	60917060-00	A	SCREW M3*6 PH FZY (SEMS)	1

- Sequence
- 1. Remove E-RING (6). And disassemble BEARING(5).
And disassemble ASS'Y SHAFT(1)(2)(3).
And then IDLER ROLLER PIN(4).
- 2. Unscrew SCREW(7). And disassemble SPACER-A(4).

TOOL	+ SCREW DRIVER , PINCETTE PI 5 E-RING TOOL.
------	--

DOC NO	CHM-1XXX CASE TYPE SERVICE MANUAL	REV	PAGE	DATE
8202-0024		B	24 OF 57	2011. 12. 15
PART (3)	DISASSEMBLE & CHANGE	PROCESS	ASS'Y MOTOR & ASS'Y ENCODER Disassembly	

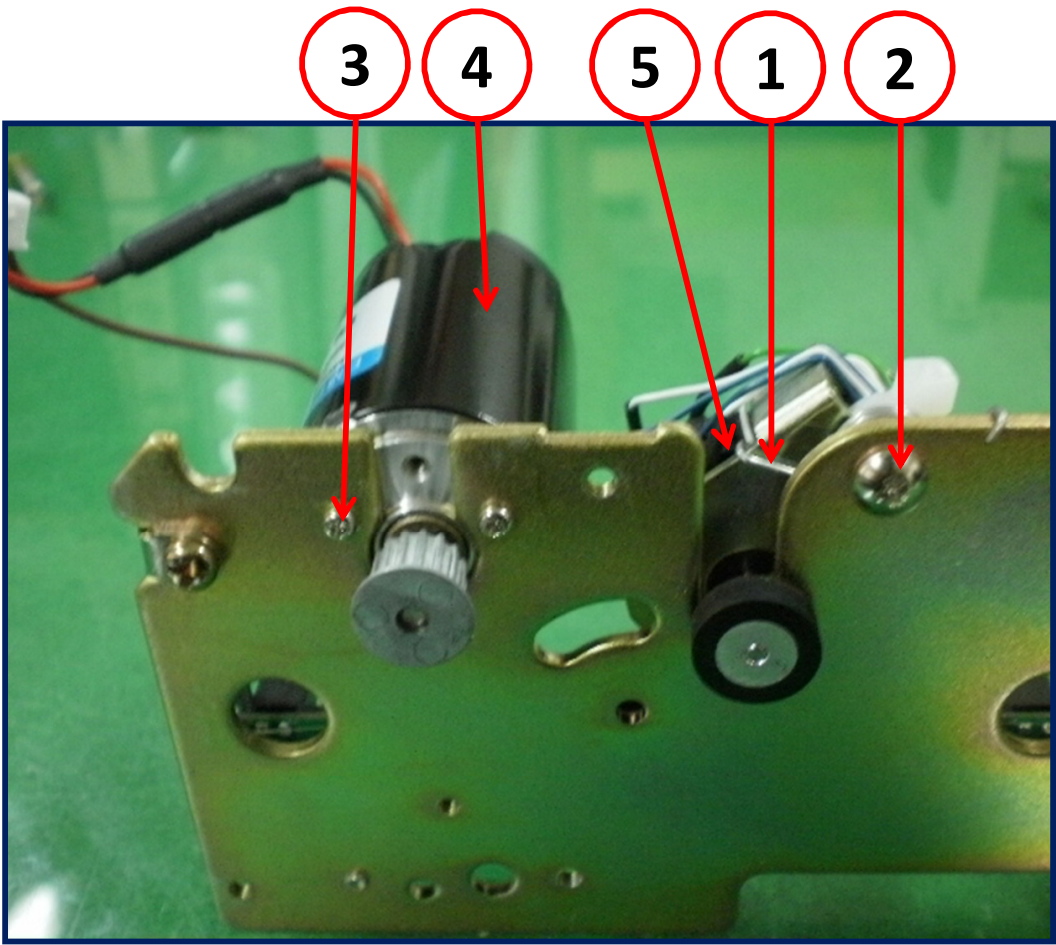

NO	PART NO	REV	PATR NAME / SPEC	Q'TY
1	76200020-00	A	ENCODER SPRING	1
2	60617063-00	A	SCREW M3*6 TH FNW	1
3	60112060-00	A	SCREW M2*4 PH FNW	3
4	89420012-00	A	ASS'Y MOTOR (15 MXL PULLEY)	1
5	89400030-00	A	ASS'Y ENCODER	1

- Sequence
- 1. Unscrew SCREW(2). And disassemble ENCODER SPRING(1) and ASS'Y ENCODER(5).
- 2. Unscrew SCREW(3). And disassemble ASS'Y MOTOR (4).

TOOL	+ SCREW DRIVER
------	----------------

DOC NO	CHM-1XXX CASE TYPE SERVICE MANUAL	REV	PAGE	DATE
8202-0024		B	25 OF 57	2011. 12. 15
PART (3)	DISASSEMBLE & CHANGE	PROCESS	ASS'Y SIDE TENSION Disassembly	

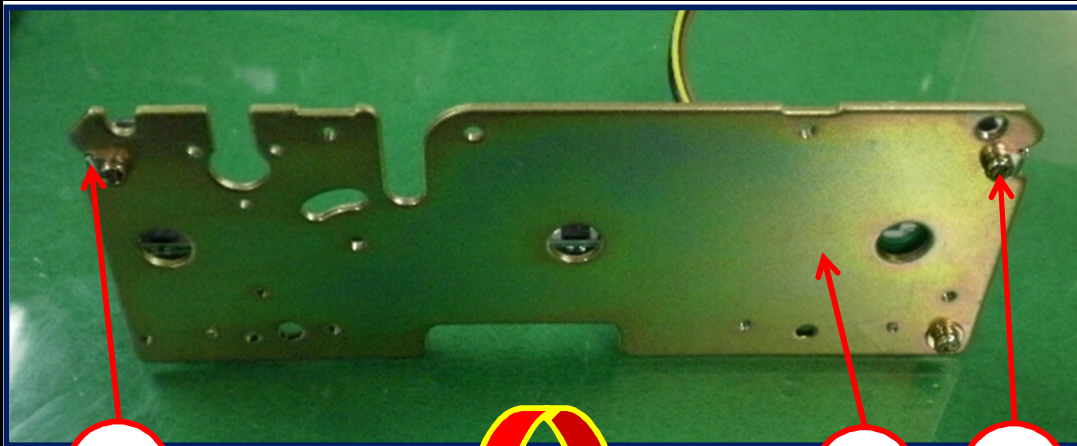

2

1

3

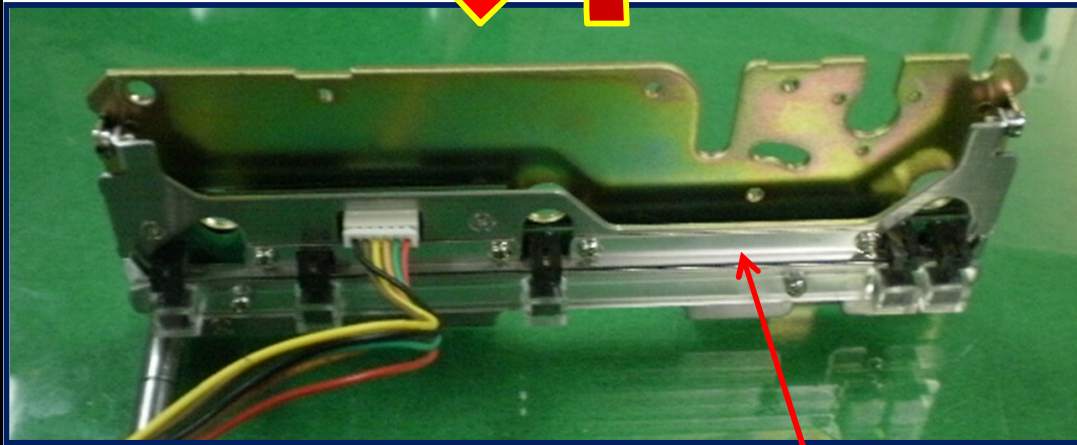

ASS'Y SIDE-TENSION

NO	PART NO	REV	PATR NAME / SPEC	Q'TY
1	69010037-00	B	FRAME-L	1
2	69030007-00	A	SLIDE MOUNTER	2
3	60117030-00	A	SCREW M3*3 PH FZY	2

- Sequence
- 1. Unscrew SCREW(3), and then disassemble FRAME-L(1), SLIDE MOUNTER(2).

TOOL	+ SCREW DRIVER
------	----------------

DOC NO	CHM-1XXX CASE TYPE SERVICE MANUAL	REV	PAGE	DATE
8202-0024		B	26 OF 57	2011. 12. 15
PART (IV)	PARTS REPLACEMENT	PROCESS	ASS'Y SENSOR PCB & ASS'Y SIDE TENSION Disassembly	

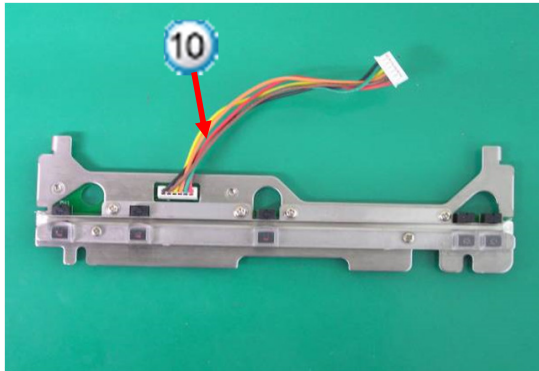
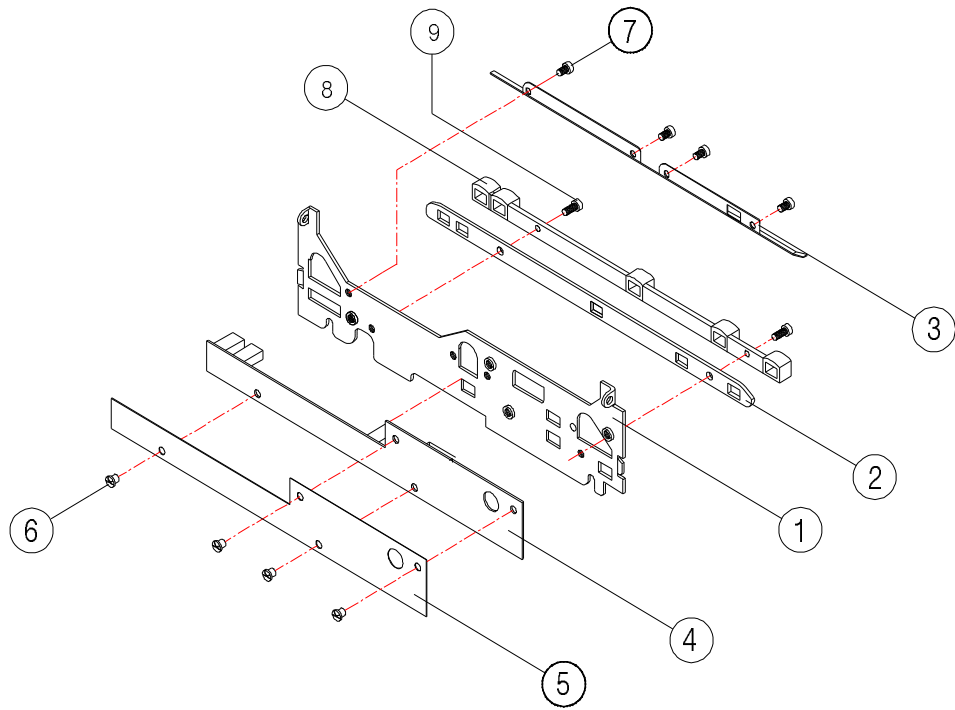

NO	PART NO	REV	PATR NAME / SPEC	Q'TY
1	70000034-00	B	SIDE TENSION NEW	1
2	70010021-00	A	GUIDE-B	1
3	70010022-00	A	GUIDE-C	1
4	89280226-00	A	SENSOR PCB'A	1
5	78930003-00	A	SENSOR PCB COVER	1
6	60927063-00	A	SCREW CONTACT M3*4 PH FNW	4
7	60916033-00	A	SCREW M2.6*3.3 FNW	4
8	67020001-00	A	SENSOR COVER	1
9	60816063-00	A	SCREW M2.6*6 BH FNW	2
10	89263621-00	A	ASS'Y SENSOR CABLE (6P / 150mm)	1

● Sequence

1. Disassemble ASS'Y SENSOR CABLE (10).
2. Unscrew SCREW (9). And disassemble GUIDE-B (2) and SENSOR COVER (8) from SIDE TENSION NEW (1).
3. Unscrew SCREW (7). And disassemble GUIDE-C (3).
4. Unscrew SCREW (6). And disassemble SENSOR PCB COVER (5) and SENSOR PCB'A (4).

※ NOTE

- When assembling SENSOR PCB'A (4), assemble with SENSOR PCB COVER (5).

TOOL	+ SCREW DRIVER , PINCETTE
------	---------------------------

DOC NO	CHM-1XXX CASE TYPE SERVICE MANUAL	REV	PAGE	DATE
8202-0024		B	27 OF 57	2011. 12. 15
PART (3)	DISASSEMBLE & CHANGE	PROCESS	ASS'Y CAPTURE BOX GUIDE Disassembly	

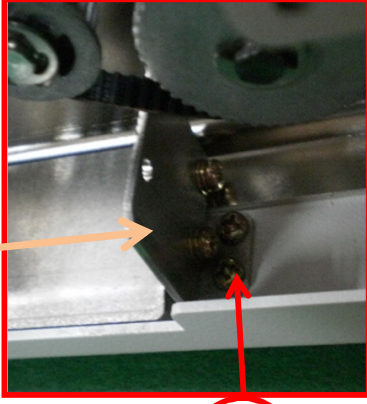
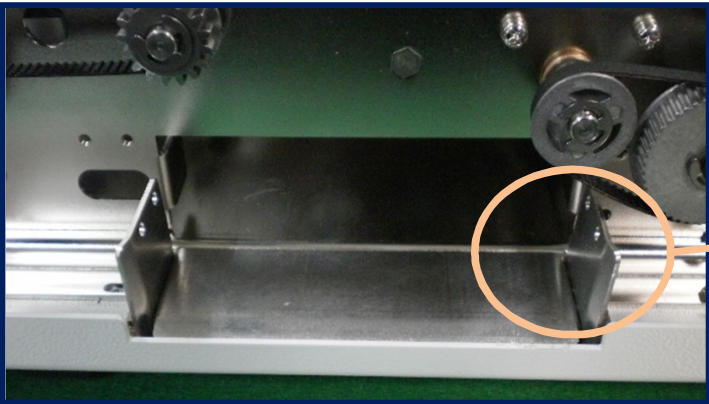

1

NO	PART NO	REV	PATR NAME / SPEC	Q'TY
1	60117030-00	A	SCREW PH M3*3 FZY	4
2	69030116-00	A	BOX BASE BRKT	1
3	69030117-00	A	BOX GUIDE BRKT	2
4	60917061-00	A	SCREW PH M3*6 FZY (SEMS SMALL)	4

● Sequence

1. Unscrew SCREW(1), and then disassemble ASS'Y BOX GUIDE BRKT.
1. Unscrew SCREW(4), and then disassemble BRKT(2)(3).

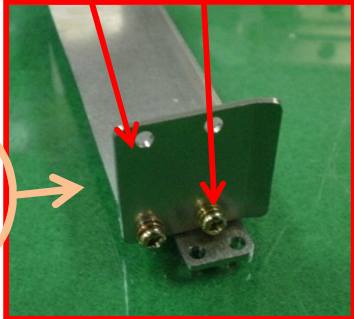
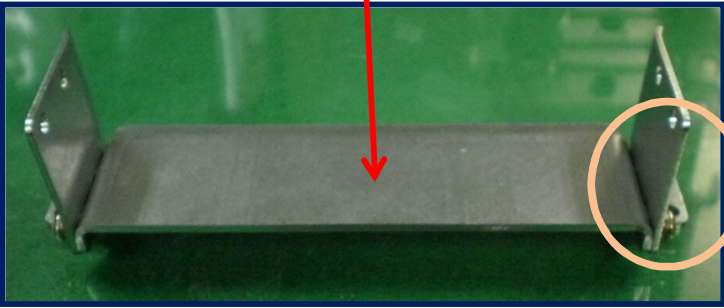

TOOL	+ SCREW DRIVER
------	----------------

DOC NO	CHM-1XXX CASE TYPE SERVICE MANUAL	REV	PAGE	DATE
8202-0024		B	28 OF 57	2011. 12. 15
PART (3)	DISASSEMBLE & CHANGE	PROCESS	ASS'Y PCB Disassembly	

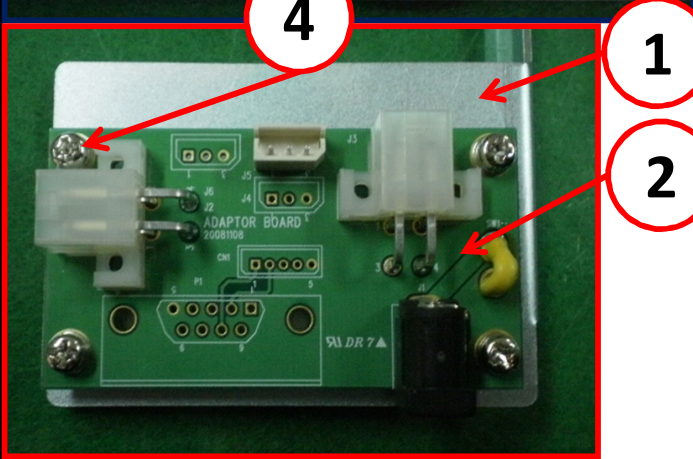
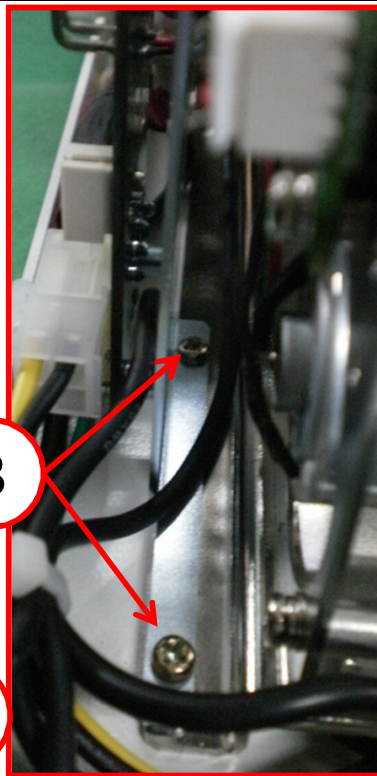
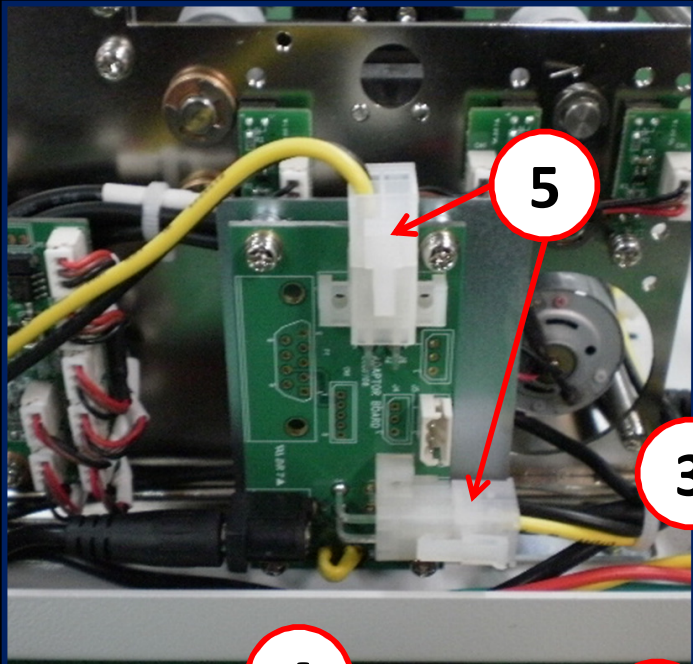

NO	PART NO	REV	PATR NAME / SPEC	Q'TY
1	69030113-00	A	POWER PCB BRKT	1
2	89280245-00	A	POWER PCB	1
3	60117030-00	A	SCREW PH M3*3 FZY	2
4	60917063-00	A	SCREW PH M3*6 FNW (SEMS SMALL)	4
5	89268013-00	A	POWER CABLE (DISPENSER, MAIN)	2

● Sequence

1. Pull out all cables.
2. Unscrew SCREW(3), and then disassemble POWER PCB BRKT(1).
3. Unscrew SCREW(4), and then disassemble PCB(2).

TOOL	+ SCREW DRIVER
------	----------------

DOC NO	CHM-1XXX CASE TYPE SERVICE MANUAL	REV	PAGE	DATE
8202-0024		B	29 OF 57	2011. 12. 15
PART (3)	DISASSEMBLE & CHANGE	PROCESS	ASS'Y DISPENSER Disassembly	

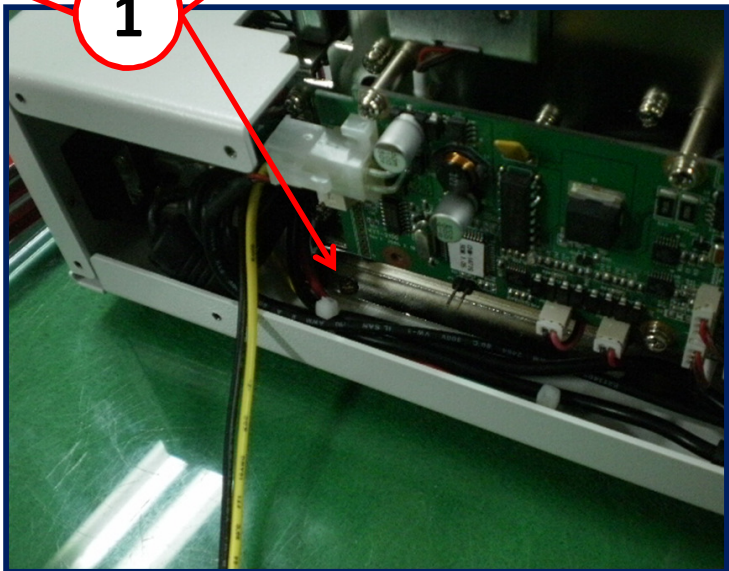
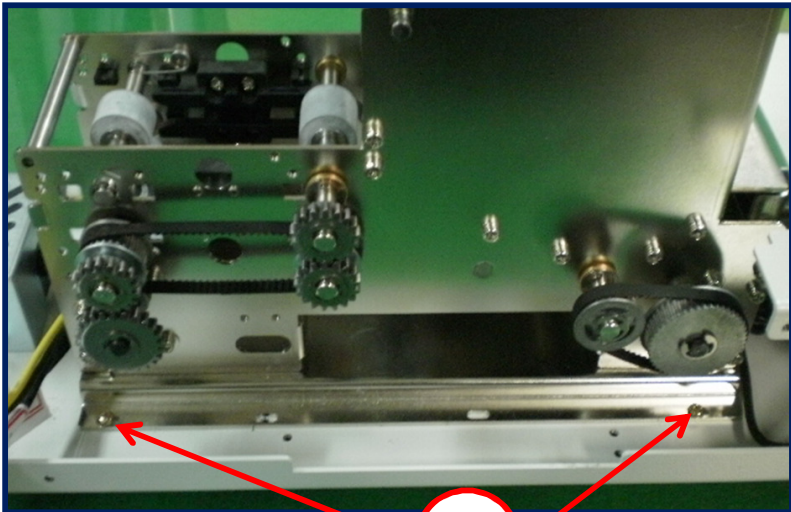

NO	PART NO	REV	PATR NAME / SPEC	Q'TY
1	60117030-00	A	SCREW PH M3*3 FZY	3

- Sequence
1. Unscrew SCREW(1), and then disassemble ASS'Y DISPENSER.

TOOL	+ SCREW DRIVER
------	----------------

DOC NO	CHM-1XXX CASE TYPE SERVICE MANUAL	REV	PAGE	DATE
8202-0024		B	30 OF 57	2011. 12. 15
PART (3)	DISASSEMBLE & CHANGE	PROCESS	ASS'Y PCB COVER Disassembly	

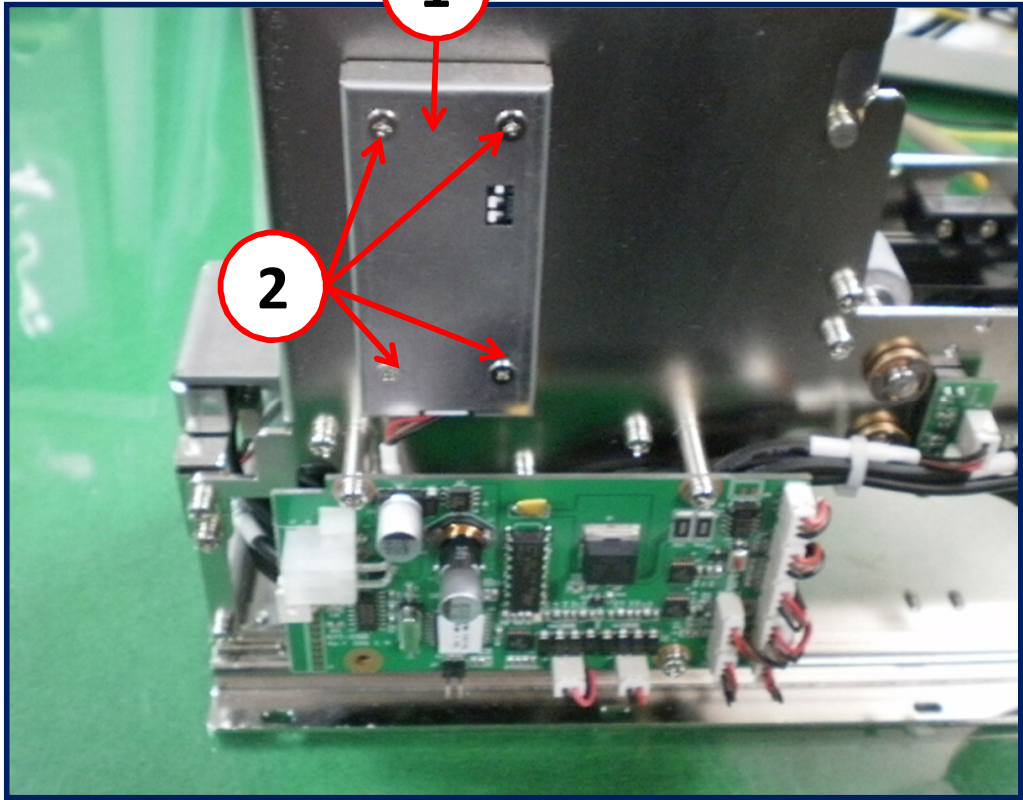

NO	PART NO	REV	PATR NAME / SPEC	Q'TY
1	72300017-00	A	PCB COVER (WARNING SENSOR)	1
2	60927063-00	A	SCREW CONTACT M3*5 0.5P FNW	4

● Sequence
 1. Unscrew CONTACT SCREW(2), and then disassemble PCB COVER(1).

TOOL	+ SCREW DRIVER
------	----------------

DOC NO	CHM-1XXX CASE TYPE SERVICE MANUAL	REV	PAGE	DATE
8202-0024		B	31 OF 57	2011. 12. 15
PART (3)	DISASSEMBLE & CHANGE	PROCESS	ASS'Y CABLE connection position	

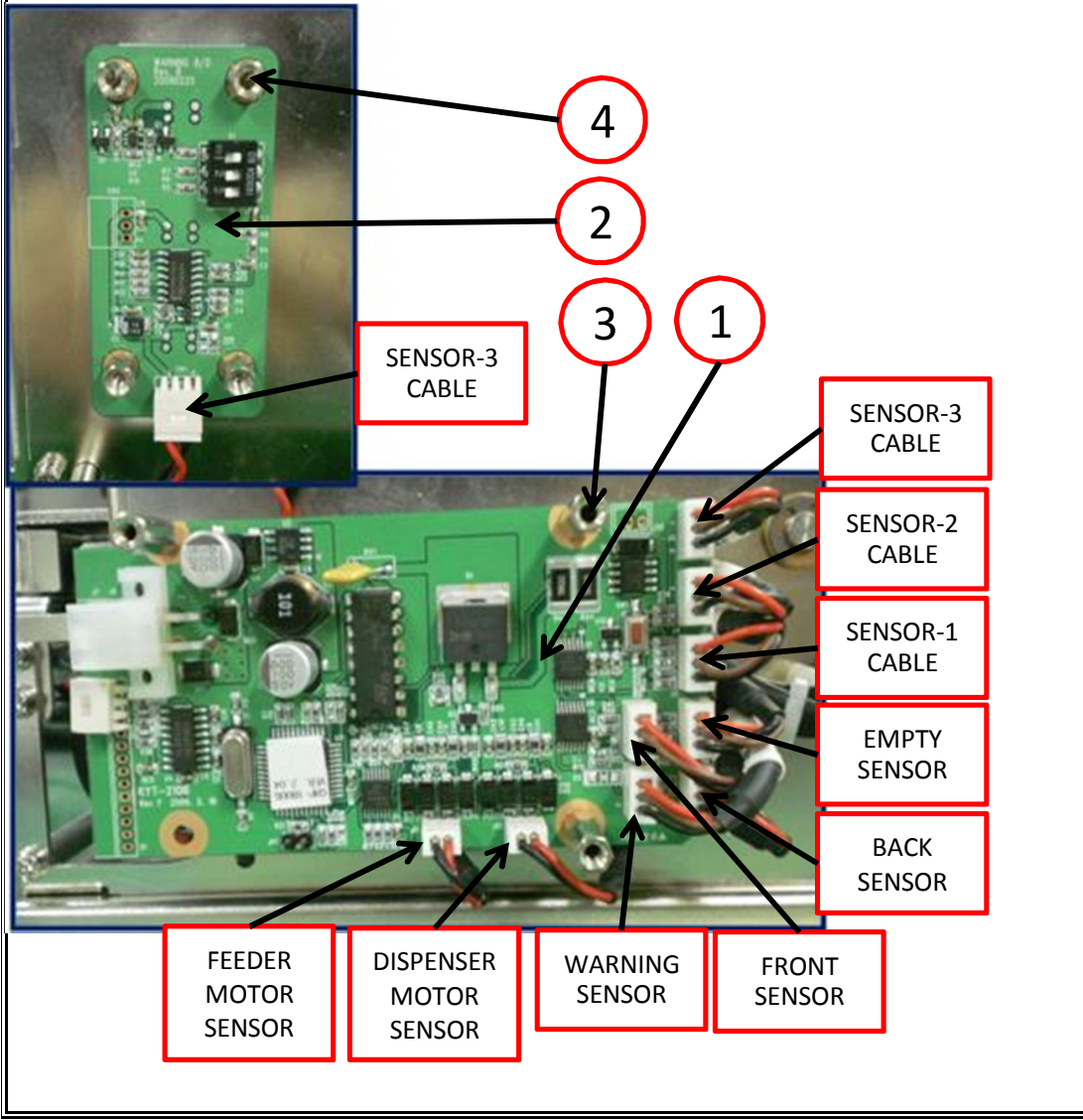

NO	PART NO	REV	PATR NAME / SPEC	Q'TY
1	89520606-00	A	ASS'Y MAIN PCB (KHT-22XX)	1
2	57020105-01	A	ASS'Y WARNING SENSOR (SG-105 B/D)	1
3	72330005-00	A	POST NUT M3*15	3
4	72330001-00	A	POST NUT M3*5	4

● Sequence

1. Pull out all cables.
2. Unscrew both POST NUT(1) and POST NUT(2) by using 5mm HEX NUT DRIVER.

TOOL	PINCETTE, 5mm HEX NUT DRIVER
------	------------------------------

DOC NO	CHM-1XXX CASE TYPE SERVICE MANUAL	REV	PAGE	DATE
8202-0024		B	32 OF 57	2011. 12. 15
PART (3)	DISASSEMBLE & CHANGE	PROCESS	ASS'Y SENSOR PCB Disassembly	

NO	PART NO	REV	PATR NAME / SPEC	Q'TY
1	57020268-01	D	ASS'Y SENSOR PCB SG 268 - L	2
2	57020268-02	D	ASS'Y SENSOR PCB SG 268 - R	1
3	89262281-00	A	ASS'Y FEED SENSOR-3 CABLE	1
4	89262282-00	A	ASS'Y FEED SENSOR-2 CABLE	1
5	89262283-00	A	ASS'Y FEED SENSOR-1 CABLE	1
6	60917083-00	A	SCREW M3.0*8L FNW (SEMS SMALL)	3
7	70220043-00	A	SENSOR SPACER	3

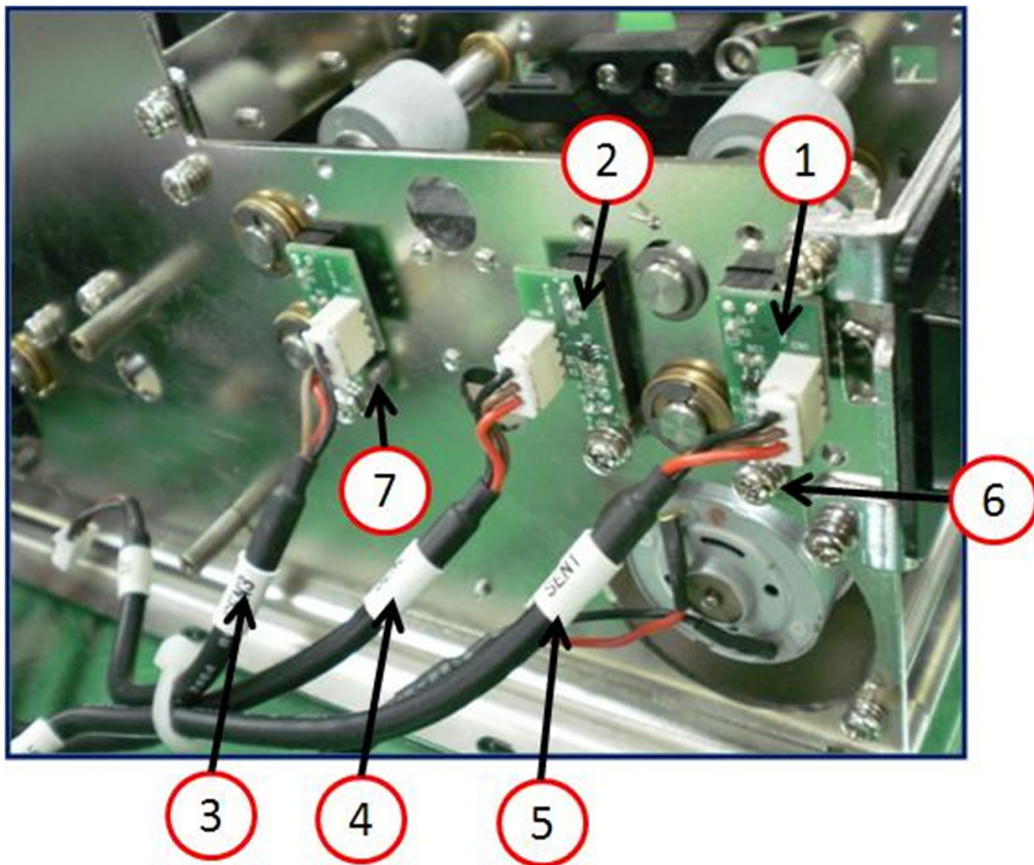

● Sequence

1. Pull out CABLE(3), CABLE(4) and CABLE(5).
2. Unscrew SCREW(6), and then disassemble both SENSOR(1) and SENSOR(2).

TOOL	PINCETTE, + SCREW DRIVER
------	--------------------------

DOC NO	CHM-1XXX CASE TYPE SERVICE MANUAL	REV	PAGE	DATE
8202-0024		B	33 OF 57	2011. 12. 15
PART (3)	DISASSEMBLE & CHANGE	PROCESS	ASS'Y BASE BRKT Disassembly	

NO	PART NO	REV	PATR NAME / SPEC	Q'TY
1	69010086-00	A	BASE BRKT	1
2	60917061-00	A	SCREW M3*6 PH FZY (SEMS SMALL)	4

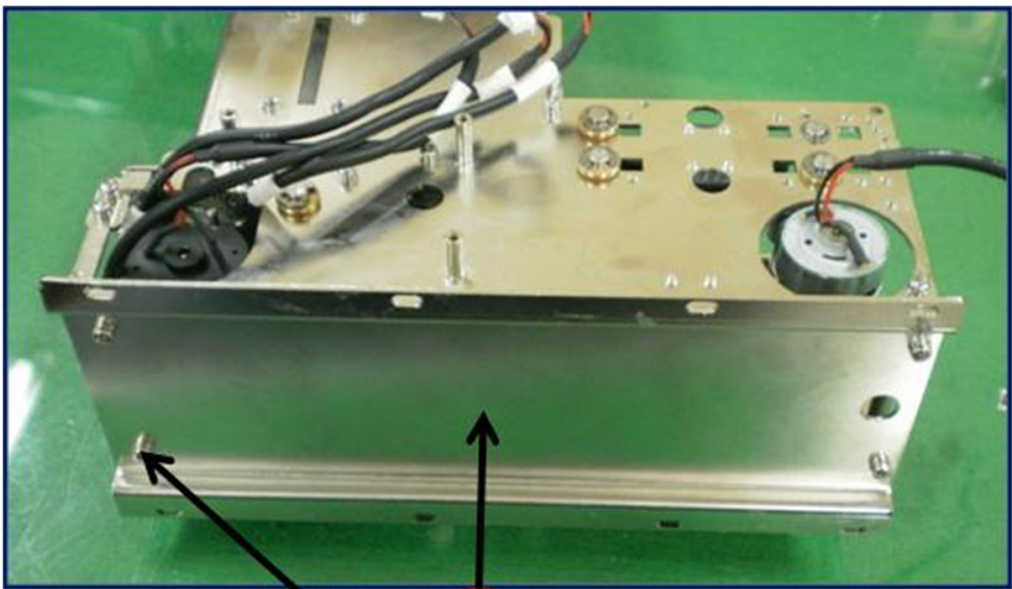

2 1

● Sequence
 1. Unscrew SCREW(2), and then disassemble BASE BRKT(1).

TOOL	+ SCREW DRIVER
------	----------------

DOC NO	CHM-1XXX CASE TYPE SERVICE MANUAL	REV	PAGE	DATE
8202-0024		B	34 OF 57	2011. 12. 15
PART (3)	DISASSEMBLE & CHANGE	PROCESS	ASS'Y FRONT DOOR Disassembly	

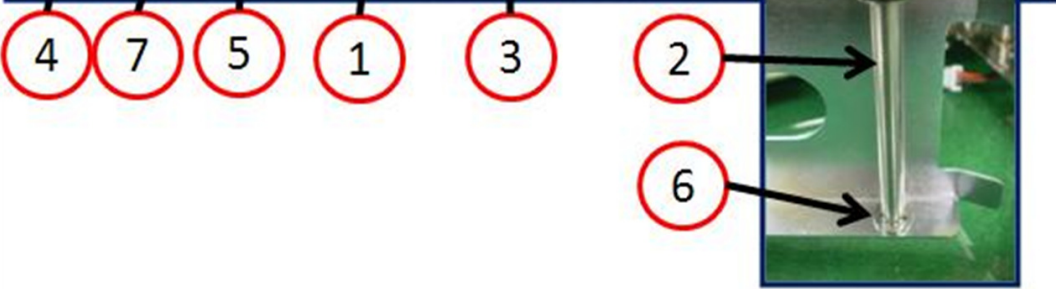
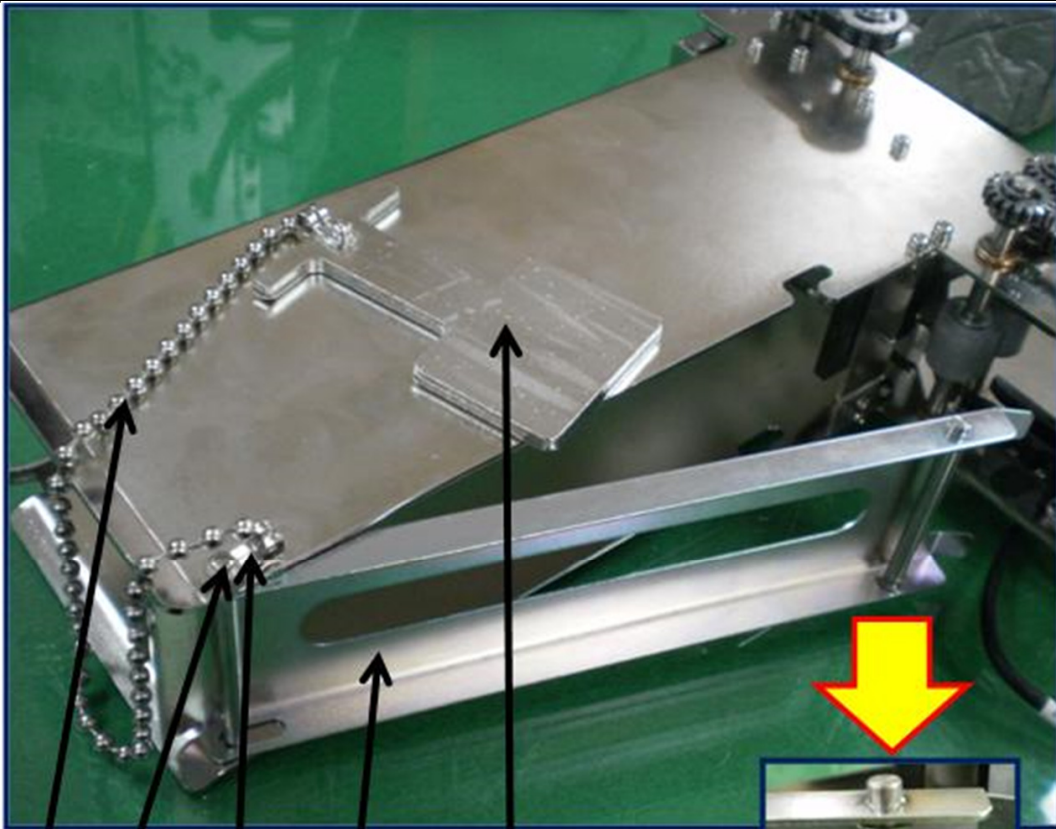

NO	PART NO	REV	PATR NAME / SPEC	Q'TY
1	69020005-00	A	FRONT DOOR 200PCS	1
	69020006-00	A	FRONT DOOR 300PCS	1
	69020007-00	A	FRONT DOOR 500PCS	1
2	70230009-00	A	LOCK PIN	1
3	70040002-00	A	WEIGHT	1
4	74250005-00	A	BALL CHAIN 240mm	1
5	72110001-00	A	CHAIN CLIP	2
6	76210013-00	A	E-RING PI 4.0 SUS	2
7	60917062-00	A	SCREW PH M3*6L FNW (SEMS)	2

● Sequence

1. Unscrew SCREW(7), and then disassemble both FRONT DOOR(3) and WEIGHT(4).
2. Remove E-ring(6) by using pincette, and then pull out LOCK PIN(2).

TOOL	+ SCREW DRIVER , PINCETTE
------	---------------------------

DOC NO	CHM-1XXX CASE TYPE SERVICE MANUAL	REV	PAGE	DATE
8202-0024		B	35 OF 57	2011. 12. 15
PART (3)	DISASSEMBLE & CHANGE	PROCESS	ASS'Y STOPPER Disassembly	

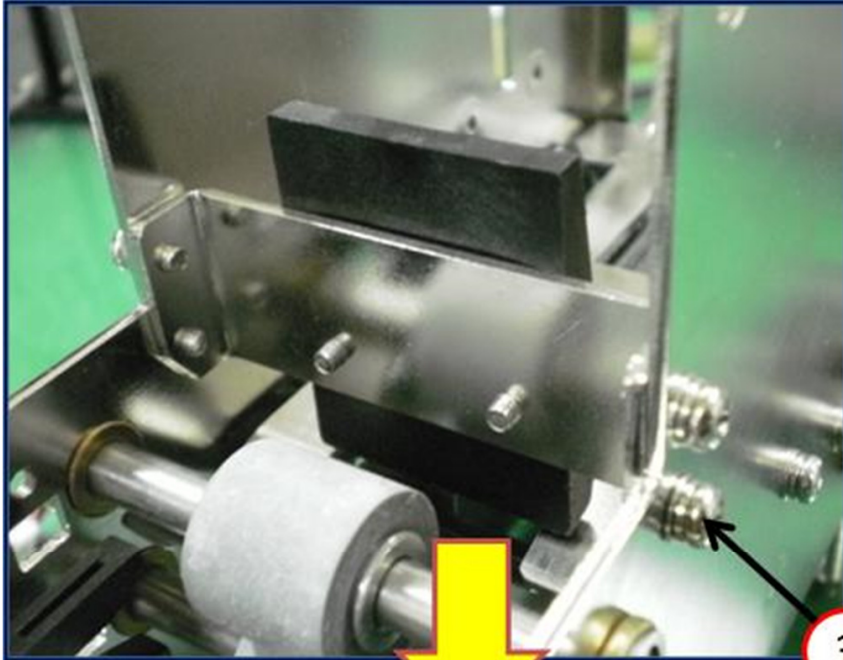

**89140011
ASS'Y STOPPER**

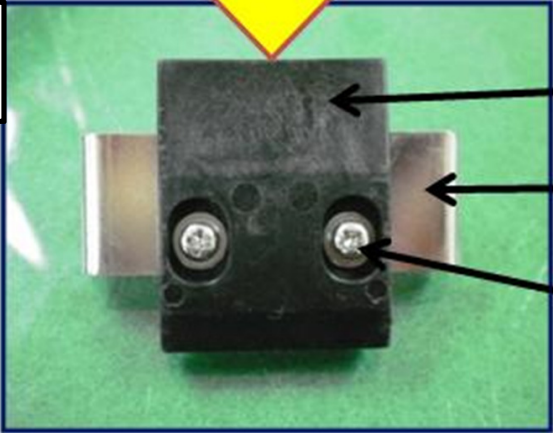

NO	PART NO	REV	PATR NAME / SPEC	Q'TY
1	70000123-00	A	STOPPER BRKT	1
2	72250002-00	A	STOPPER	1
3	60917063-00	A	SCREW PH M3*6L FNW (SEMS SMALL)	4
4	60917085-00	A	SCREW PH M3*8L FNW (SEMS)	2

- Sequence
- 1. Unscrew SCREW(3) by using plus driver, and then disassemble ASS'Y STOPPER.
- 2. Unscrew SCREW(4), and then disassemble both STOPPER BRKT(1) and STOPPER(2).

TOOL	+ SCREW DRIVER
------	----------------

DOC NO	CHM-1XXX CASE TYPE SERVICE MANUAL	REV	PAGE	DATE
8202-0024		B	36 OF 57	2011. 12. 15
PART (3)	DISASSEMBLE & CHANGE	PROCESS	ASS'Y PULLEY, GEAR Disassembly	

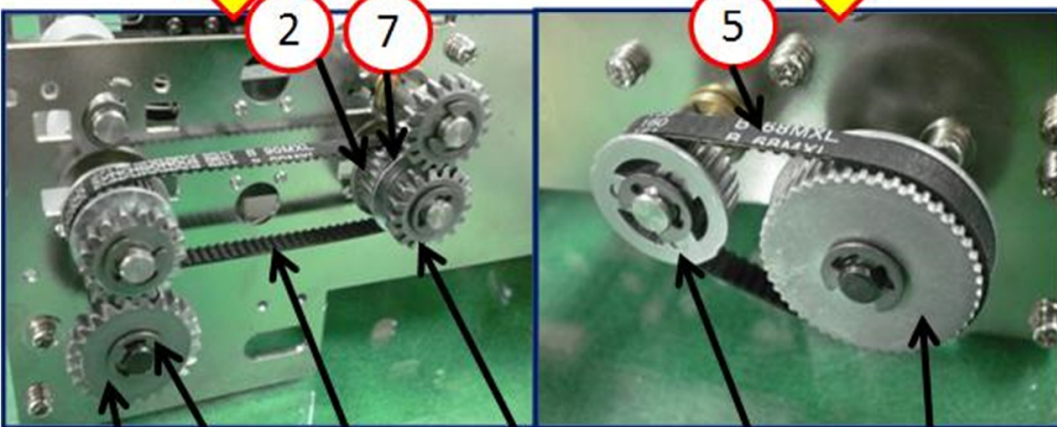
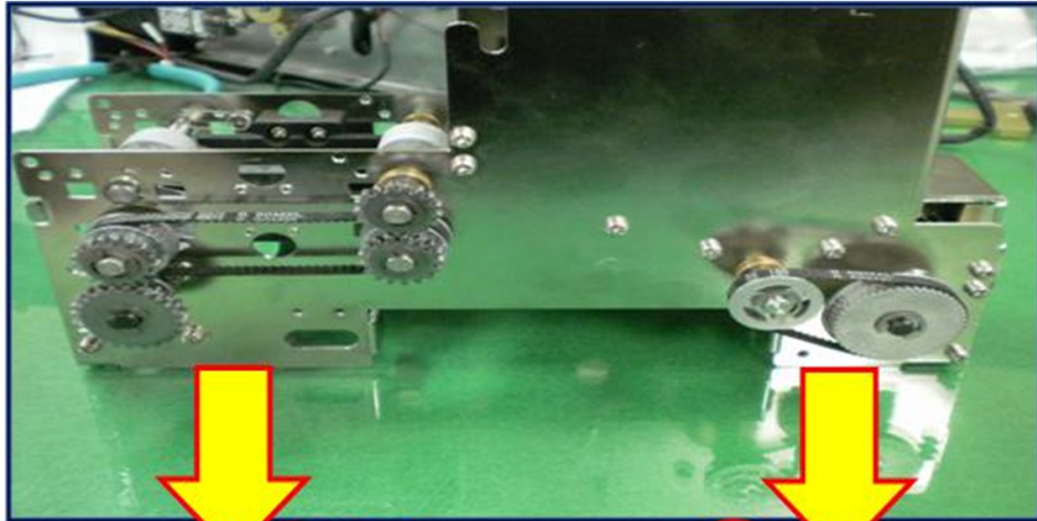

NO	PART NO	REV	PATR NAME / SPEC	Q'TY
1	74210016-00	A	TIMING PULLEY AL 47MXL	1
2	74210015-00	A	TIMING PULLEY AL 29MXL	3
3	74200004-00	B	FEED GEAR - 17	3
4	74200001-00	B	FEED GEAR - 24	1
5	74250038-00	A	BELT 68 MXL * 4.8	1
6	74250017-00	A	BELT 90 MXL * 4.8	1
7	63020012-00	A	PLATE WASHER	2
8	76210013-00	A	E-RING PI 4.0 SUS	6

- Sequence
1. Remove E-ring(8) by using pincette, and then pull out PULLEY(1), PULLEY(2) and BELT(5).
 2. Remove E-ring(8), and then disassemble both GEAR(3) and GEAR(4).
 3. Pull out WASHER(8), and then pull out PULLEY(2) and BELT(6).

TOOL	PINCETTE
------	----------

DOC NO	CHM-1XXX CASE TYPE SERVICE MANUAL	REV	PAGE	DATE
8202-0024		B	37 OF 57	2011. 12. 15
PART (3)	DISASSEMBLE & CHANGE	PROCESS	ASS'Y CARD BASE Disassembly	

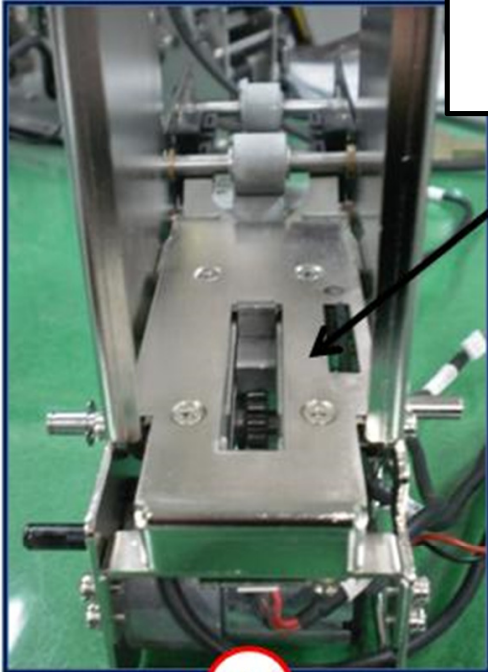

**89410019
ASS'Y CARD BASE**



NO	PART NO	REV	PATR NAME / SPEC	Q'TY
1	60917063-00	A	SCREW PH M3*6L FNW (SEMS SMALL)	8

- Sequence
1. Unscrew SCREW(2) by using plus driver, and then disassemble ASS'Y CARD BASE BRKT.

TOOL	+ SCREW DRIVER
------	----------------

DOC NO	CHM-1XXX CASE TYPE SERVICE MANUAL	REV	PAGE	DATE
8202-0024		B	38 OF 57	2011. 12. 15
PART (3)	DISASSEMBLE & CHANGE	PROCESS	ASS'Y CARD BASE BRKT Disassembly	

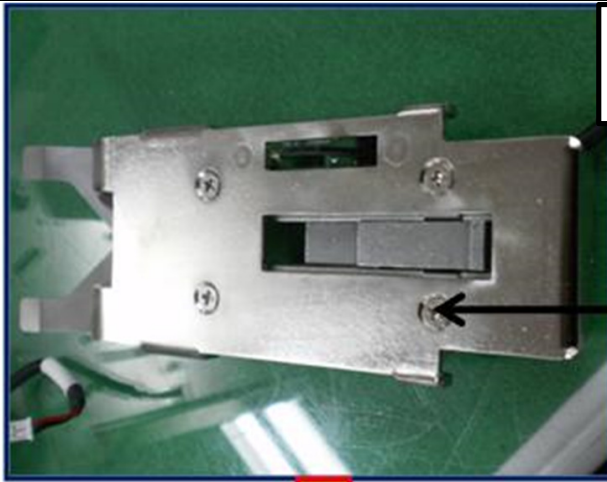

89410019
ASS'Y CARD BASE

5

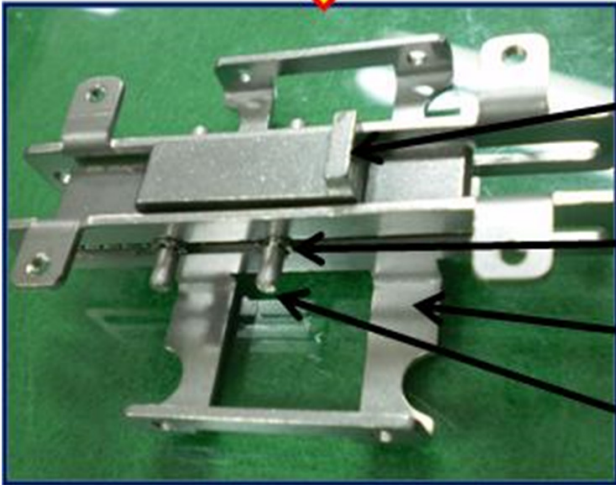

1

4

2

3

NO	PART NO	REV	PATR NAME / SPEC	Q'TY
1	74200005-00	B	RACK GEAR	1
2	74900003-00	B	SLIDE SUPPORT BRKT	2
3	70230061-00	A	PIN STOPPER	2
4	70610011-00	A	E-RING PI 2.0 SUS	4
5	60417049-00	A	SCREW FH M3*4L FNW	4

● Sequence

1. Unscrew SCREW(5) by using plus driver, and then disassemble ASS'Y CARD BASE BRKT.
2. Remove E-ring(6) by using pincette, and then disassemble both RACK GEAR(2) and BRKT(3).

TOOL	PINCETTE, + SCREW DRIVER
------	--------------------------

DOC NO	CHM-1XXX CASE TYPE SERVICE MANUAL	REV	PAGE	DATE
8202-0024		B	39 OF 57	2011. 12. 15
PART (3)	DISASSEMBLE & CHANGE	PROCESS	ASS'Y EMPTY SENSOR Disassembly	

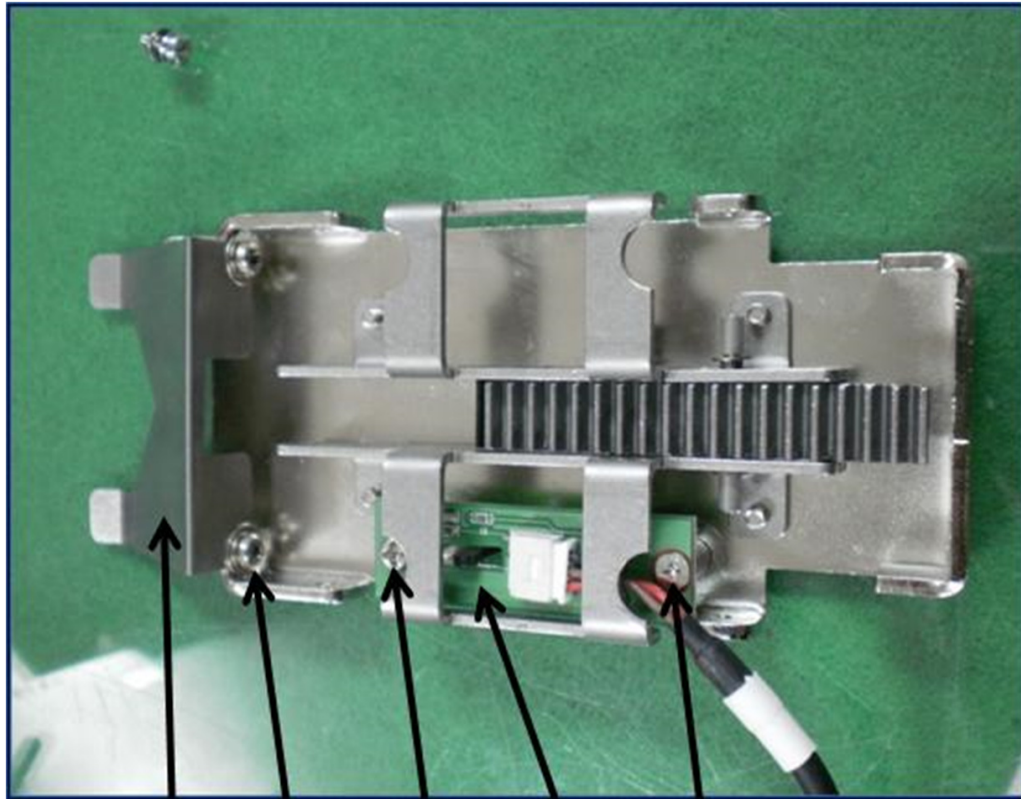

NO	PART NO	REV	PATR NAME / SPEC	Q'TY
1	70010056-00	A	CAPTURE GUIDE	1
2	89280228-00	A	ASS'Y EMPTY SENSOR	1
3	60917062-00	A	SCREW PH M3*6 FNW (SEMS)	2
4	60917063-00	A	SCREW PH M3*6 FNW (SEMS SMALL)	1
5	60927063-00	A	SCREW CONTACT M3*5 FNW	1

● Sequence

1. Unscrew SCREW(3) by using plus driver, and then pull out CAPTURE GUIDE(1).
2. Unscrew both SCREW(4) and SCREW(5), and then disassemble SENSOR(2).

TOOL	+ SCREW DRIVER
------	----------------

DOC NO	CHM-1XXX CASE TYPE SERVICE MANUAL	REV	PAGE	DATE
8202-0024		B	40 OF 57	2011. 12. 15
PART (III)	DISASSEMBLE & CHANGE	PROCESS	ASS'Y MOTOR Disassembly	

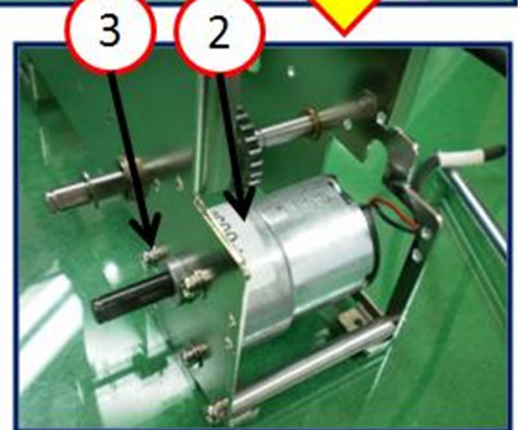
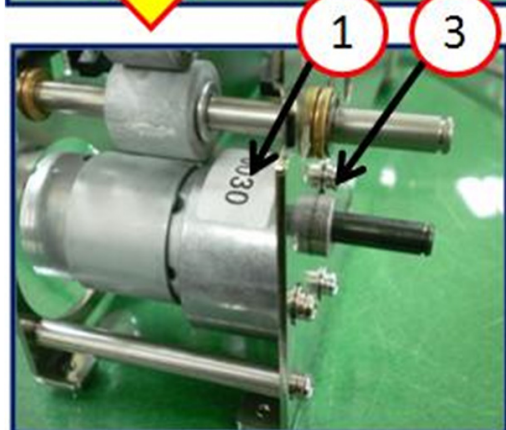
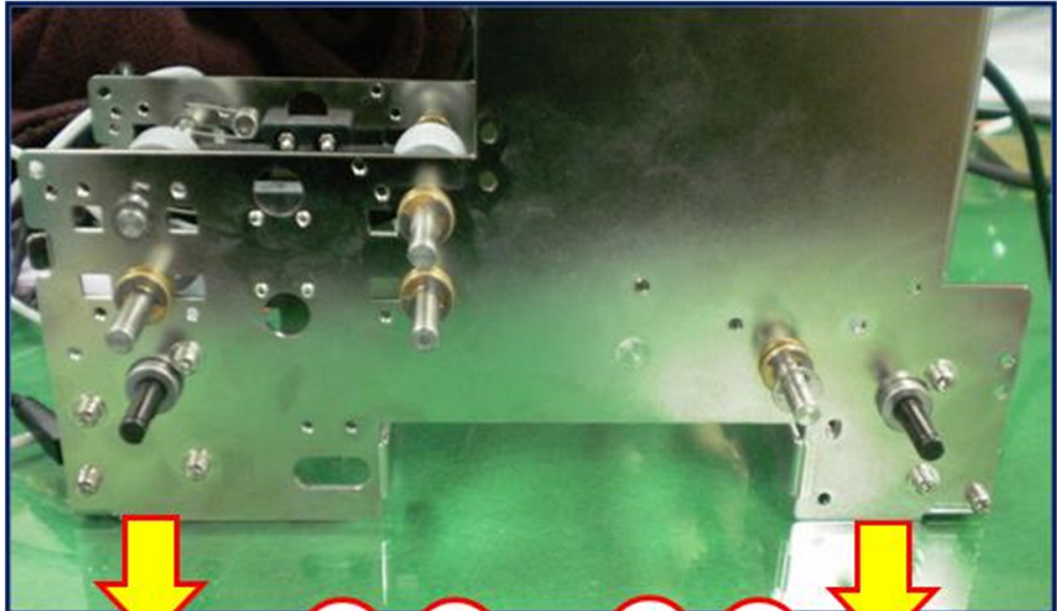

NO	PART NO	REV	PATR NAME / SPEC	Q'TY
1	89160016-00	A	ASS'Y FEEDER MOTOR	1
2	89160014-00	A	ASS'Y DISPENSER MOTOR	1
3	60917062-00	A	SCREW M3*6 PH FNW (SEMS)	6

● Sequence
 1. Unscrew SCREW(3) by using plus driver, and then disassemble both MOTOR(1) and MOTOR(2).

TOOL	+ SCREW DRIVER
------	----------------

DOC NO	CHM-1XXX CASE TYPE	REV	PAGE	DATE
8202-0024	SERVICE MANUAL	B	41 OF 57	2011. 12. 15
PART (III)	DISASSEMBLE & CHANGE	PROCESS	AS'Y SHAFT Disassembly	

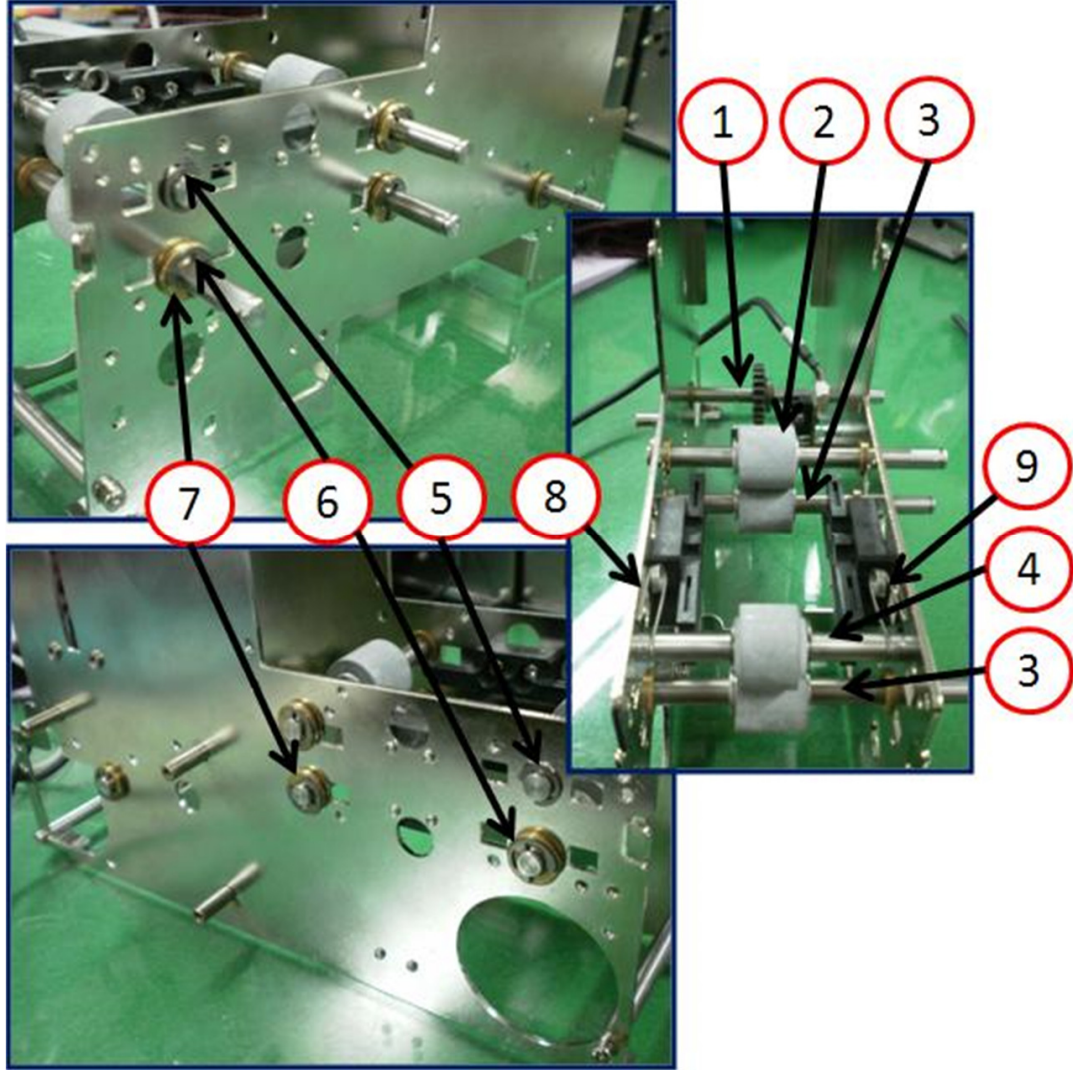

NO	PART NO	REV	PATR NAME / SPEC	Q'TY
1	89110038-00	A	ASS'Y MAIN SHAFT	1
2	89110034-00	A	ASS'Y FEEDING SHAFT	1
3	89110020-00	A	ASS'Y FEEDING SHAFT	2
4	89101234-00	B	ASS'Y IDLER SHAFT	1
5	76210013-00	A	E-RING PI 4.0	2
6	76210014-00	A	E-RING PI 5.0	8
7	70310002-00	A	OILLESS BEARING	8
8	76200031-00	A	IDLER SPRING-L	1
9	76200032-00	A	IDLER SPRING-R	1

- Sequence
1. Pull out both SPRING(8) and SPRING(9).
 2. Remove both E-ring(6) and E-ring(5) by using pincette, and then pull out OILLESS BEARING(7).
 3. Pull out all ASS'Y SHAFTs.

TOOL	PINCETTE
------	----------

DOC NO	CHM-1XXX CASE TYPE SERVICE MANUAL	REV	PAGE	DATE
8202-0024		B	42 OF 57	2011. 12. 15
PART (3)	DISASSEMBLE & CHANGE	PROCESS	ASS'Y GUIDE BRKT Disassembly	

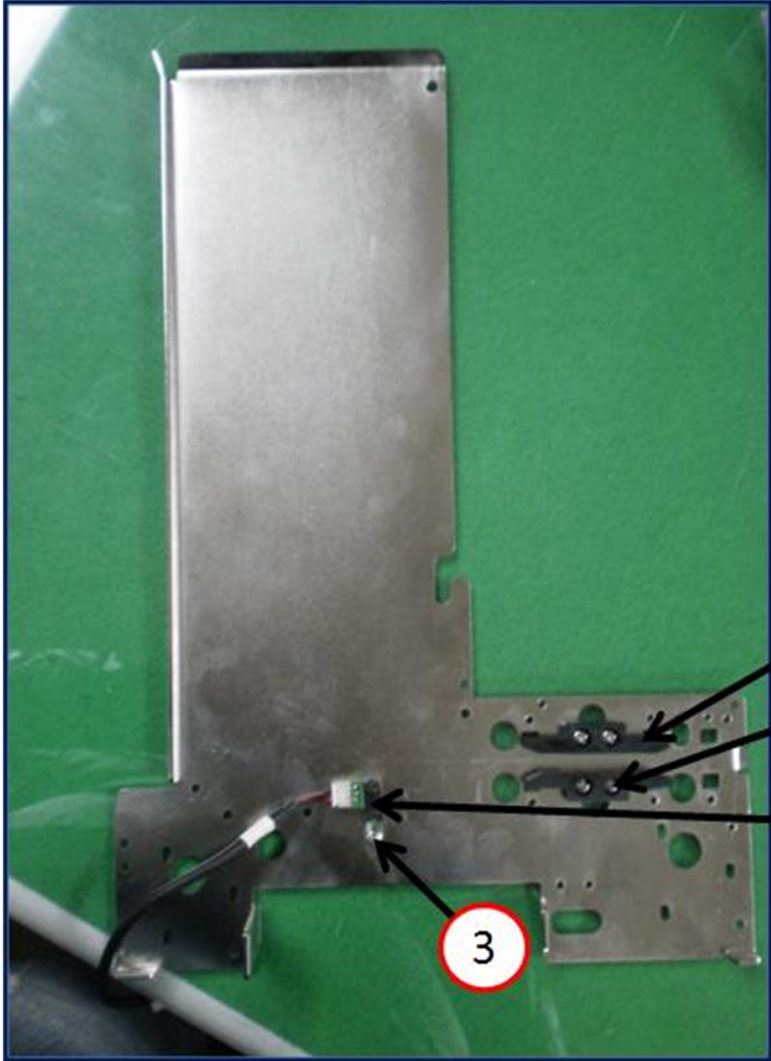

NO	PART NO	REV	PATR NAME / SPEC	Q'TY
1	70010059-00	A	GUIDE BRKT	2
2	57020207-04	B	ASS'Y SENSOR SG207-L Angle type	1
3	60917063-00	A	SCREW M3*6 PH FNW (SEMS SMALL)	5

● Sequence

1. Unscrew SCREW(3) by using plus driver, and then disassemble GUIDE BRKT(1) and SENSOR(2).

TOOL	+ SCREW DRIVER
------	----------------

DOC NO	CHM-1XXX CASE TYPE SERVICE MANUAL	REV	PAGE	DATE
8202-0024		B	43 OF 57	2011. 12. 15
PART (3)	DISASSEMBLE & CHANGE	PROCESS	ASS'Y GUIDE Disassembly	

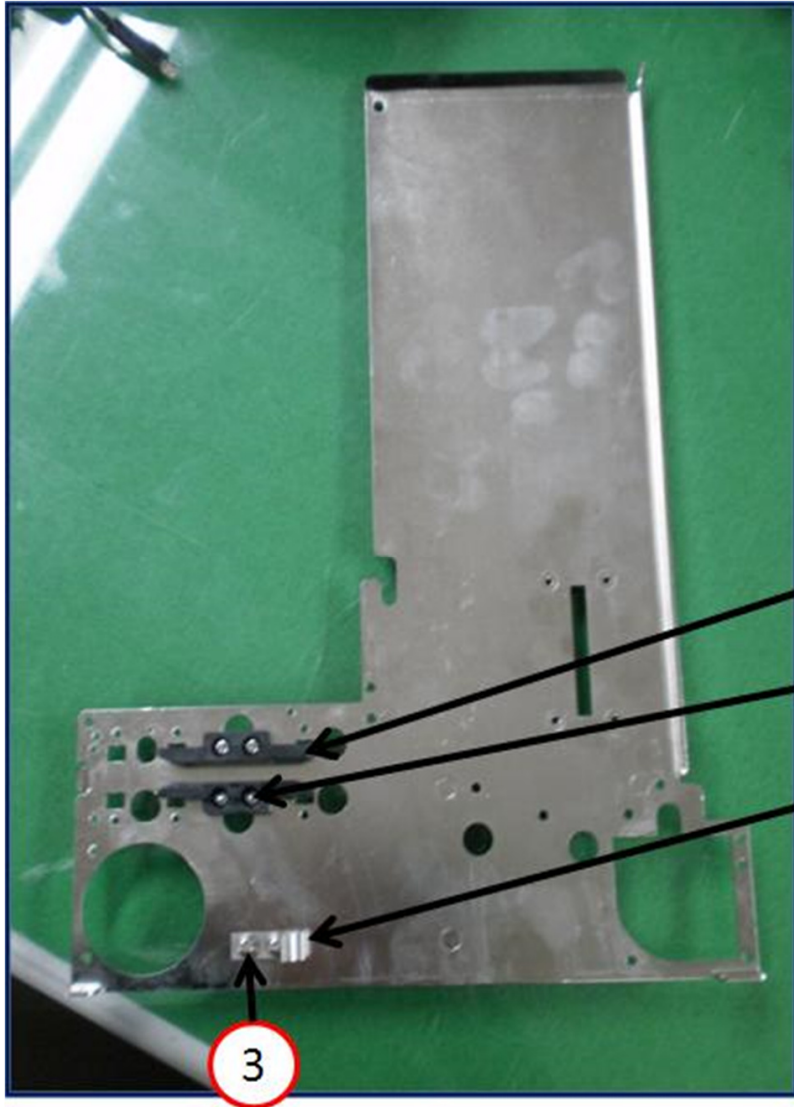

NO	PART NO	REV	PATR NAME / SPEC	Q'TY
1	70010059-00	A	GUIDE BRKT	2
2	76200040-00	A	PLATE SPRING	1
3	60917063-00	A	SCREW M3*6 PH FNW (SEMS SMALL)	6

● Sequence

1. Unscrew SCREW(3) by using plus driver, and then disassemble both GUIDE BRKT(1) and PLATE SPRING(2).

TOOL	+ SCREW DRIVER
------	----------------

DOC NO	CHM-1XXX CASE TYPE SERVICE MANUAL	REV	PAGE	DATE
8202-0024		B	44 OF 57	2011. 12. 15
PART (3)	DISASSEMBLE & CHANGE	PROCESS	ASS'Y IDLER SHAFT Disassembly	

89101234
ASS'Y IDLER SHAFT

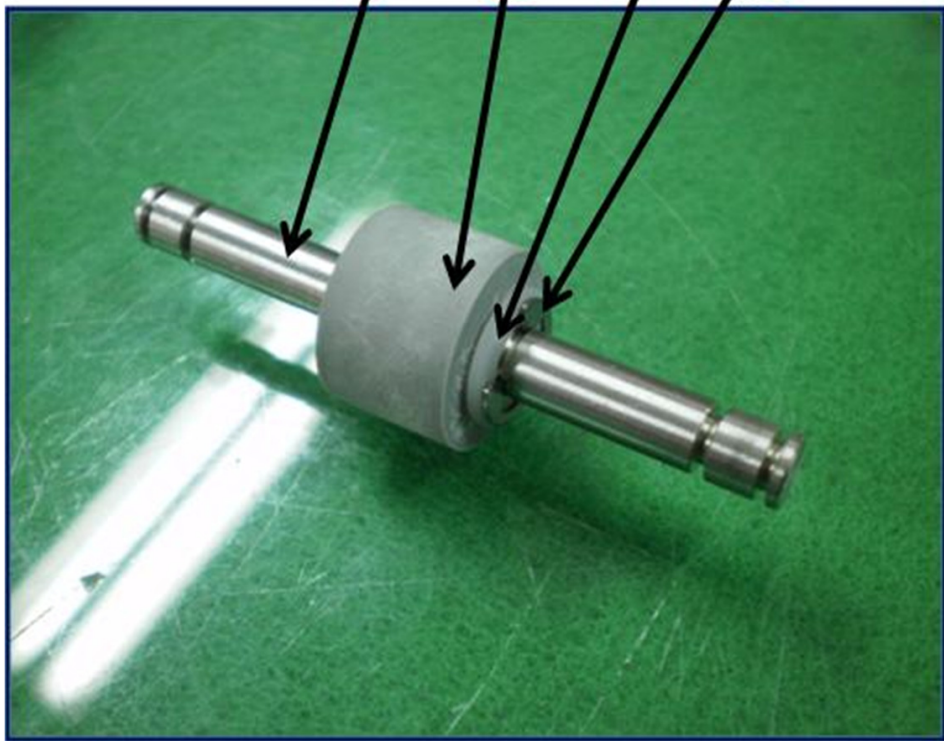

NO	PART NO	REV	PATR NAME / SPEC	Q'TY
1	70220085-00	A	IDLER SHAFT	1
2	74120044-00	A	BOBBIN	1
3	74120002-00	B	FRONT ROLLER	1
4	76210014-00	A	E-RING PI 5.0	2

● Sequence
 1. Remove E-RING(4) by using pincette, and then disassemble both BOBBIN(2) and ROLLER(3).

TOOL	PINCETTE
------	----------

DOC NO	CHM-1XXX CASE TYPE SERVICE MANUAL	REV	PAGE	DATE
8202-0024		B	45 OF 57	2011. 12. 15
PART (3)	DISASSEMBLE & CHANGE	PROCESS	ASS'Y MAIN SHAFT Disassembly	



NO	PART NO	REV	PATR NAME / SPEC	Q'TY
1	70220103-00	A	MAIN SHAFT	1
2	74200001-00	B	FEED GEAR - 24	1
3	76210014-00	A	E-RING PI 5.0	1

● Sequence
 1. Remove E-ring(3), and then disassemble GEAR(2).

TOOL	PINCETTE
------	----------

DOC NO	CHM-1XXX CASE TYPE SERVICE MANUAL	REV	PAGE	DATE
8202-0024		B	46 OF 57	2011. 12. 15
PART (3)	DISASSEMBLE & CHANGE	PROCESS	ASS'Y FEEING SHAFT Disassembly	

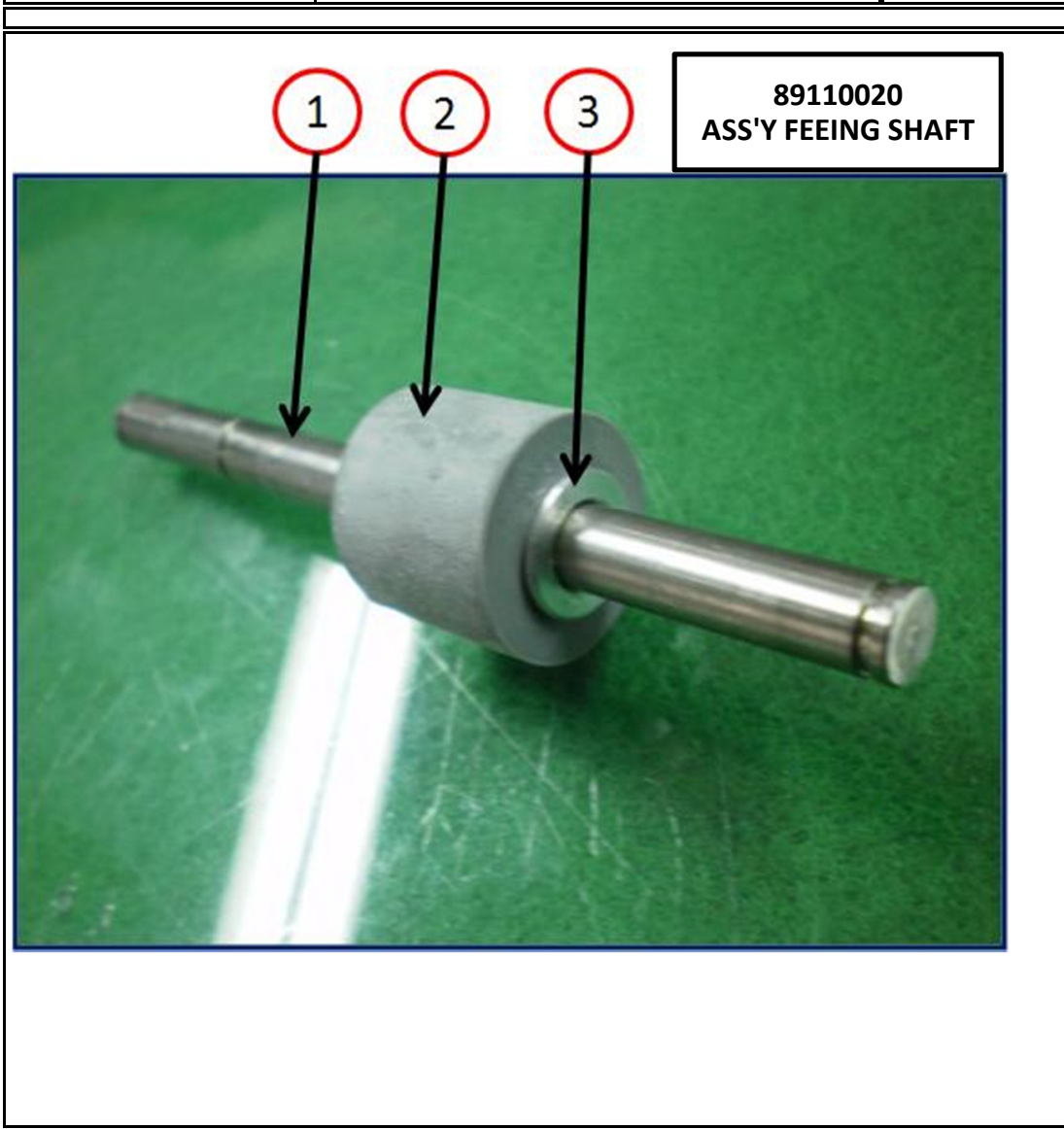

NO	PART NO	REV	PATR NAME / SPEC	Q'TY
1	70220086-00	A	FEEDING SHAFT	1
2	74120003-00	B	REAR ROLLER	1
3	74120046-00	A	BOBBIN	1
<ul style="list-style-type: none"> ● Sequence 				
TOOL				

DOC NO	CHM-1XXX CASE TYPE SERVICE MANUAL	REV	PAGE	DATE
8202-0024		B	47 OF 57	2011. 12. 15
PART (3)	DISASSEMBLE & CHANGE	PROCESS	ASS'Y FEEDING SHAFT Disassembly	

**89110034
ASS'Y FEEING SHAFT**

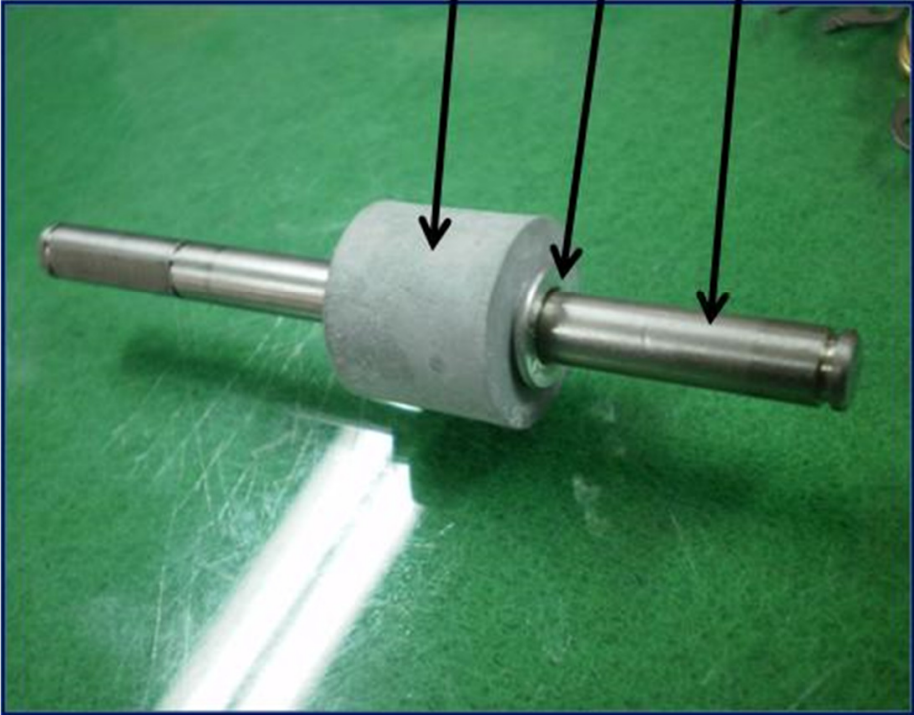

NO	PART NO	REV	PATR NAME / SPEC	Q'TY
1	70220102-00	A	FEEDING SHAFT	1
2	74120003-00	B	REAR ROLLER	1
3	74120046-00	A	BOBBIN	1

● Sequence

TOOL	
------	--

DOC NO	CHM-1XXX CASE TYPE SERVICE MANUAL	REV	PAGE	DATE
8202-0024		B	48 OF 57	2011. 12. 15
PART (3)	DISASSEMBLE & CHANGE	PROCESS	ASS'Y ADAPTURE Disassembly	

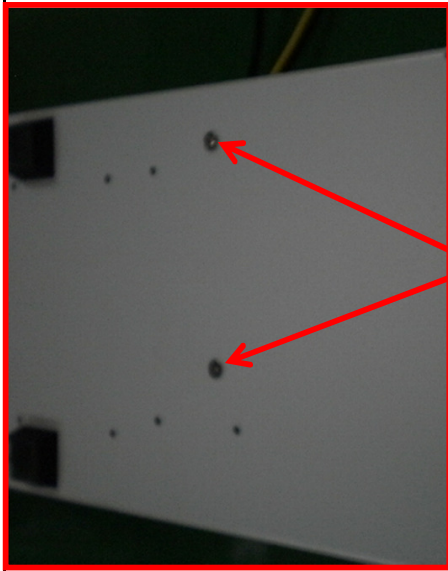
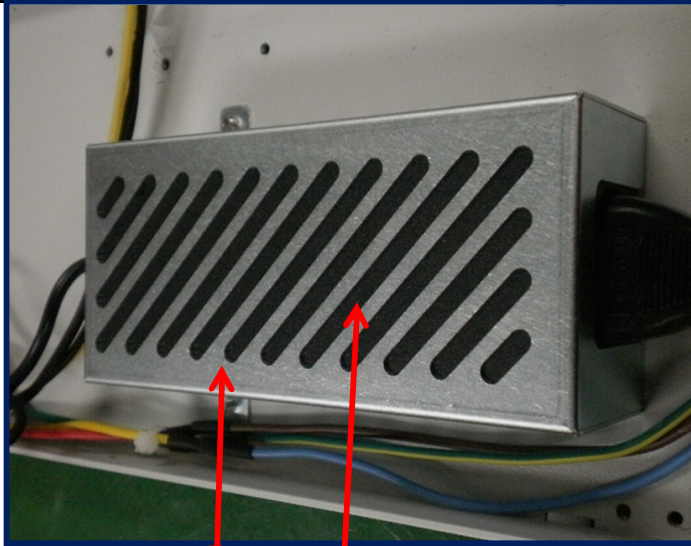

NO	PART NO	REV	PATR NAME / SPEC	Q'TY
1	89280246-00	A	AC/DC ADAPTER	1
2	69030118-00	A	ADAPTER COVER	1
3	60417060-00	A	SCREW FH M3*6 FNW	2

● Sequence
 1. Unscrew SCREW(3), and then disassemble ADAPTER COVER(2), AC/DC ADAPTER(1).

TOOL	+ SCREW DRIVER
------	----------------

DOC NO	CHM-1XXX CASE TYPE SERVICE MANUAL	REV	PAGE	DATE
8202-0024		B	49 OF 57	2011. 12. 15
PART (3)	DISASSEMBLE & CHANGE	PROCESS	ASS'Y COM CABLE Disassembly	

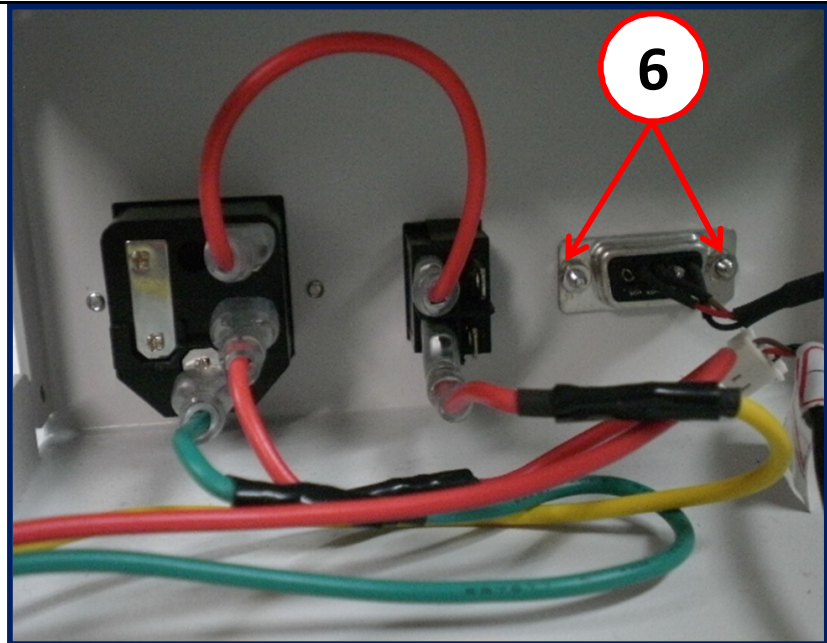







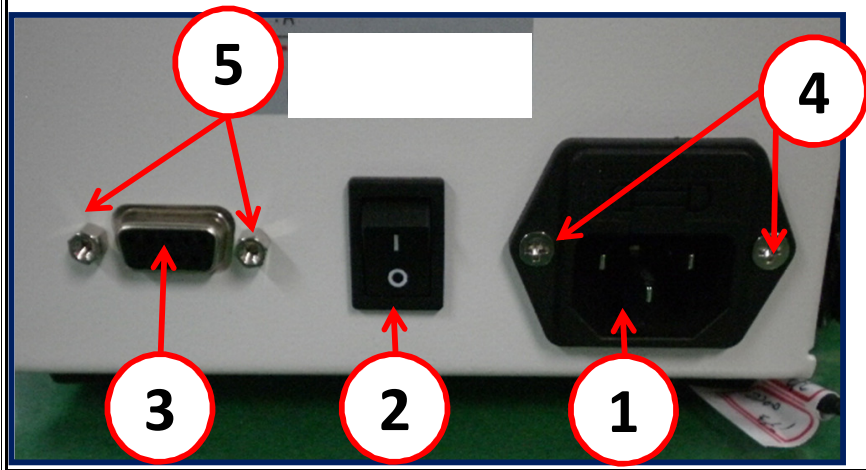





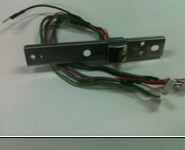





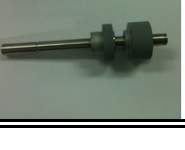



NO	PART NO	REV	PATR NAME / SPEC	Q'TY
1	49800000-00	A	AC RECEPTABLE	1
2	14100000-00	A	S/W SLED	1
3	89268073-00	A	ASS'Y COM CABLE	1
4	60417041-00	A	SCREW FH M3*5 FNW	2
5	72330010-00	A	POST NUT (UNC 4-40)	2
6	64002030-00	A	NUT (UNC 4-40)	2

- Sequence
1. Pull out all cable.
 2. Unscrew SCREW(4)(5), and then disassemble RECEPTABLE(1), ASS'Y COM CABLE(3).
 3. Pull out S/W SLED(2).



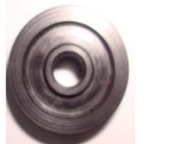









TOOL	+ SCREW DRIVER, 5mm HEX NUT DRIVER
------	------------------------------------

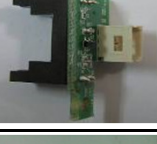

DOC NO		CHM-1XXX CASE TYPE				REV		PAGE		DATE	
8202-0024		SPARE PART LIST				B		50 OF 57		2011. 12. 15	
PART (1)		SPARE PART LIST				PROCESS		CARD READER/WRITER PART			
NO	PART NAME	OUTLINE DRAWING	QTY / UNIT		LIFE LENGTH	NO	PART NAME	OUTLINE DRAWING	QTY / UNIT		LIFE LENGTH
	(PART NUMBER)						(PART NUMBER)				
1	89503610 Ass'y Main PCB (RS 232C)		1		1,000,000 cards	8	89203050 Ass'y Ant PCB		1		1,000,000 cards
2	89203600 Ass'y Main PCB (TTL)		1		1,000,000 cards	9	74250014 Belt 97MXL*3.8		1		500,000 cards
3	89460004 Ass'y IC-Contact		1		700,000 times (20℃, 0.76mm)	10	74250015 Belt 112MXL*3.8		1		500,000 cards
4	Ass'y Head Brkt 89000033 (LOW-CO) 89000034 (HI-CO) 89000039(HI&LOW- CO)		1		700,000 times (20℃, 0.76mm)	11	89100087 Ass'y Card Base		1		
5	89100077 Ass'y Shaft-A		1		300,000 cards	12	89420021 Ass'y DC Motor (15MXL)		1		1,000,000 cards
6	89100078 Ass'y Shaft-B		1		300,000 cards	13	74250036 Belt 118MXL*4.8		1		500,000 cards
7	89100079 Ass'y Shaft-C		1		300,000 cards	14	76200021 Head Spring		1		500,000 cards

DOC NO		CHM-1XXX CASE TYPE				REV		PAGE		DATE	
8202-0024		SPARE PART LIST				B		51 OF 57		2011. 12. 15	
PART (1)		SPARE PART LIST			PROCESS		CARD READER/WRITER PART				
NO	PART NAME	OUTLINE DRAWING	QTY / UNIT	LIFE LENGTH	NO	PART NAME	OUTLINE DRAWING	QTY / UNIT	PRICE EURO / PC	LIFE LENGTH	
	(PART NUMBER)					(PART NUMBER)					
15	89257118 Ass'y Solenoide JWC 0826 (Ass'y IC Contact)		1	1,000,000 cards	22	89203030 ASSY SENSOR PCB		1			
16	89400016 Ass'y Pre Head		1	700,000 times (20 °C, 0.76mm)	23	74210008 FEEDING PULLEY (ZN 34MXL)		2		1,000,000 cards	
17	74120025 Idler Roller		2	1,000,000 cards	24	74210009 MAIN PULLEY (ZN 85MXL)		1		1,000,000 cards	
18	74120022 Idler Roller PH2		1	1,000,000 cards	25	49090001 Fan		1			
19	89410025 Ass'y Encoder		1								
20	76200020 Encoder Spring		1	500,000 cards							
21	89257121 Ass'y Solenoide JWS 1040 (Ass'y Shutter Module)		1	1,000,000 cards							

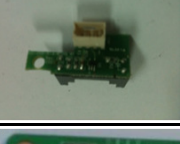
DOC NO	CHM-1XXX CASE TYPE SERVICE MANUAL	REV	PAGE	DATE
8202-0024		B	52 OF 57	2011. 12. 15
PART (4)	SPARE PART LIST	PROCESS	CARD DISPENSER	

● CARD DISPENSER PART											
NO	PART NAME	OUTLINE DRAWING	QTY / UNIT	LIFE LENGTH		NO	PART NAME	OUTLINE DRAWING	QTY / UNIT		LIFE LENGTH
	(PART NUMBER)						(PART NUMBER)				
1	89520606 Mainboard (RS-232C Interface)		1	1,000,000 cards		8	74200005 Rack Gear		1		1,000,000 cards
2	76200032 Idler Spring - R (SUS304 PI 0.6)		1	500,000 cards		9	70310002 Oilless bearing		8		500,000 cards
3	76200031 Idler Spring - L (SUS304 PI 0.6)		1	500,000 cards		10	74250017 Timing belt 90MXL*4.8		1		500,000 cards
4	74210015 Timing pulley AL 29MXL		3	1,000,000 cards		11	74250038 Timing belt 68MXL*4.8		1		500,000 cards
5	74210016 Timing pulley AL 47MXL		1	1,000,000 cards		12	57020268-01 Ass'y Sensor-L B/D SG-268 L		2		1,000,000 cards
6	74200004 Feed gear-17 (PCD 17.0*M)		3	1,000,000 cards		13	57020268-02 Ass'y Sensor-R B/D SG-268 R		2		1,000,000 cards
7	74200001 Feed gear-24 (PCD 24.0*5.0*12.0)		1	1,000,000 cards		14	57020105-01 Ass'y Warning Sensor		1		1,000,000 cards

