



Ingeniería Electrónica  
*SMART IDENT*

---

# CARD COLLECTOR

## Specifications

---

User Manual

CMT-1000 Rev. C



<b>Doc No</b>	<b>CMT-1000 SERIES SPECIFICATION</b>	<b>REV</b>	<b>PAGE</b>	<b>DATE</b>
		C	3 OF 19	2006. 10. 31.

## MODEL NAME INFORMATION

C M X - 1 0

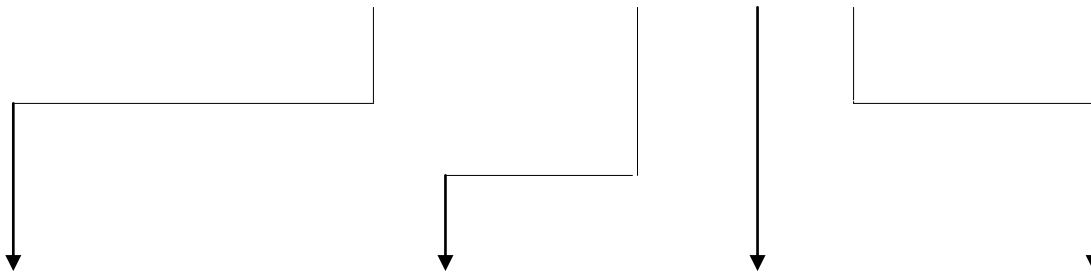

Interface	Function	TYPE	OPTION	CAPACITY
T: RS-232C L: TTL	COLLECTOR MODULE	0: SINGLE	0: STANDARD(Not Cartridge) 1: CARTRIDGE TYPE	1: 100 PCS 2: 200 PCS 3: 300 PCS 4: 500 PCS  CARD STANDARD: 0.76T

<b>Doc No</b>	<b>CMT-1000 SERIES SPECIFICATION</b>	<b>REV</b>	<b>PAGE</b>	<b>DATE</b>
			C	4 OF 19

## **C O N T E N T S**

- 1. Overview**
- 2. Features**
- 3. System Block Diagram**
- 4. Specification**
- 5. Technical Drawing**
- 6. RS232C Interface**
- 7. TTL Interface**

<b>Doc No</b>	<b>CMT-1000 SERIES SPECIFICATION</b>	<b>REV</b>	<b>PAGE</b>	<b>DATE</b>
		C	5 OF 19	2006. 10. 31.

## 1. Overview

Card Collector CMT-1000 Series with clutch system to prevent 2 cards from being collected, has very compact and robust mechanism, which leads to high reliability and easy-to-do maintenance.

It is easy to apply CMT-1000 to Card Vending Machine and other terminal products, bring price competitiveness to Users .

There are 2 types of Interface for CMT-1000 Series, TTL Interface and RS-232C Interface, which can be integrated as User requires .

Followings are major applications of CMT-1000 Series ;

- Highway toll system
- Automatic Card Collecting Equipment
- Mass card issuing System
- Parking Equipment
- Access Control System
- Kiosk, etc.

<b>Doc No</b>	<b>CMT-1000 SERIES SPECIFICATION</b>	<b>REV</b>	<b>PAGE</b>	<b>DATE</b>
		C	6 OF 19	2006. 10. 31.

## 2. Features

2-1. Card thickness dispensable can be adjusted easily.

Card thickness adjustable from 0.22mm up to 1.0mm.

2-2 . RS232C Interface

A. Baud Rate : changeable(9,600 BPS ↔ 19,200BPS)

B. Can change position of card (one way direction allowed)

C. With Self-diagnosis function

D. Easy to control

2-3. TTL Interface.

A. Can control Motor to change position of card (one way direction allowed)

B. Easy to control

2-4 . FULL SENSOR is equipped to see card full status.

## 3. System Block Diagram

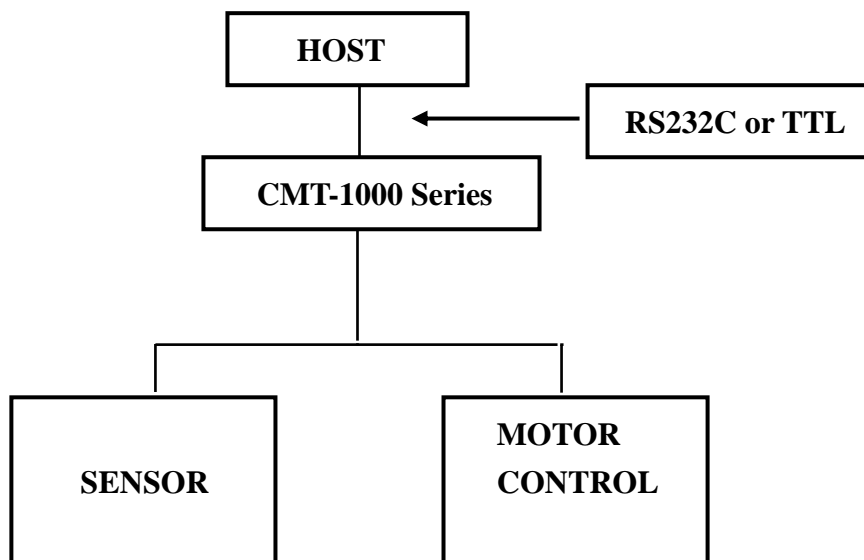

<b>Doc No</b>	<b>CMT-1000 SERIES SPECIFICATION</b>	<b>REV</b>	<b>PAGE</b>	<b>DATE</b>
		C	7 OF 19	2006. 10. 31.

## 4. Specification

MODEL(CMx-xxxx)	T-1001	L-1001	T-1002	L-1002	T-1003	L-1003	T-1004	L-1004
Interface	RS-232C	TTL	RS-232C	TTL	RS-232C	TTL	RS-232C	TTL
Microprocessor	O	X	O	X	O	X	O	X
Dimensions (W x L x H) mm	92.0 x 155.0 x 219.3		92.0 x 155.0 x 259.3		92.0 x 155.0 x 339.3		92.0 x 155.0 x 499.3	
Card Dispensing Time (Sec)	1.5		1.5		1.5		1.5	
Max. Card Loading Capacity	150 PCS		200 PCS		300 PCS		500 PCS	
Total Weight (Kg)			1.6Kg					
Applicable Cards	Phone Card, Credit, Debit, Pre_padi, I.C Card, RF Card, Parking Card							
Card Material	P.V.C, A.B.S, P.E.T, Etc.							
Max. Card Width, Max. Card Length	ISO 7810							
Max. Card Thickness	0.22 ~ 1.0 mm							
Supply Voltage & Current Consumption	Without Load : DC 24V(±5%) – 50 mA, With Load : DC 24V (±5%)– 300mA ~ 1.5 A,							
Operating Humidity	0 % ~ 90 % RH							
Operating Temperature	-5° C ~ 70° C							

### 4.1. DC Power

- . Part Number : 5569rdf-04A (MOLEX)
- . Power Connector Pin Table (PCB side)
- . Connector number : J6

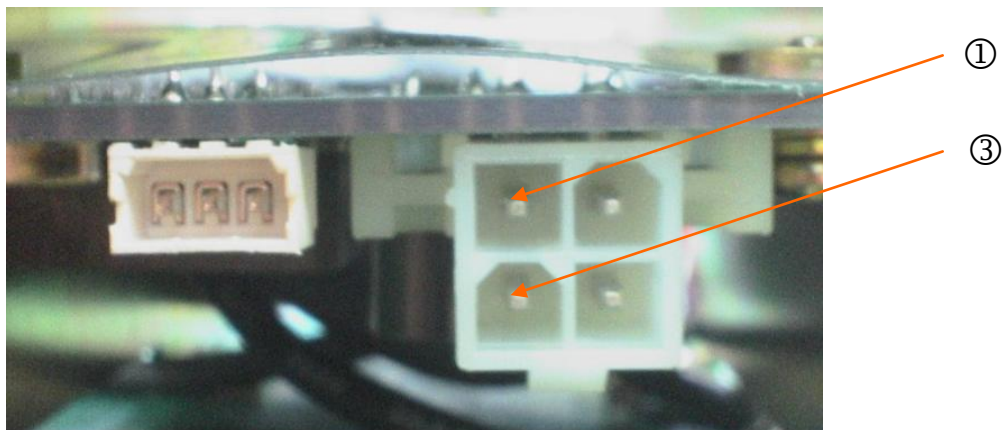

Pin NO	Signal Name	Direction
1	GND	Input
2	Not use	
3	+24VDC	
4	Not use	

<b>Doc No</b>	<b>CMT-1000 SERIES SPECIFICATION</b>	<b>REV</b>	<b>PAGE</b>	<b>DATE</b>
		C	8 OF 19	2006. 10. 31.

. Power cable configuration

PIN 1 : BLACK (OR GREEN) - GND

PIN 3 : YELLOW - +24VDC

4.2 Interface

4.2.1. RS 232C model

. Part Number : 53015-0310(Molex) , Connector number : J7

. Connect Pin Table(PCB side)

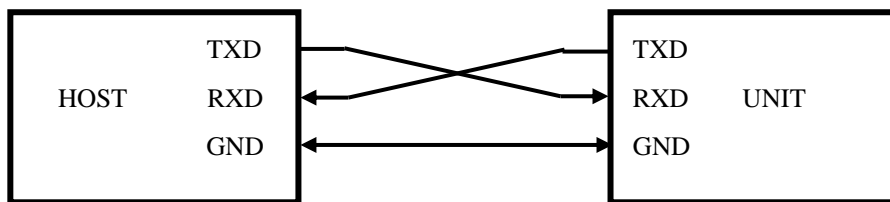
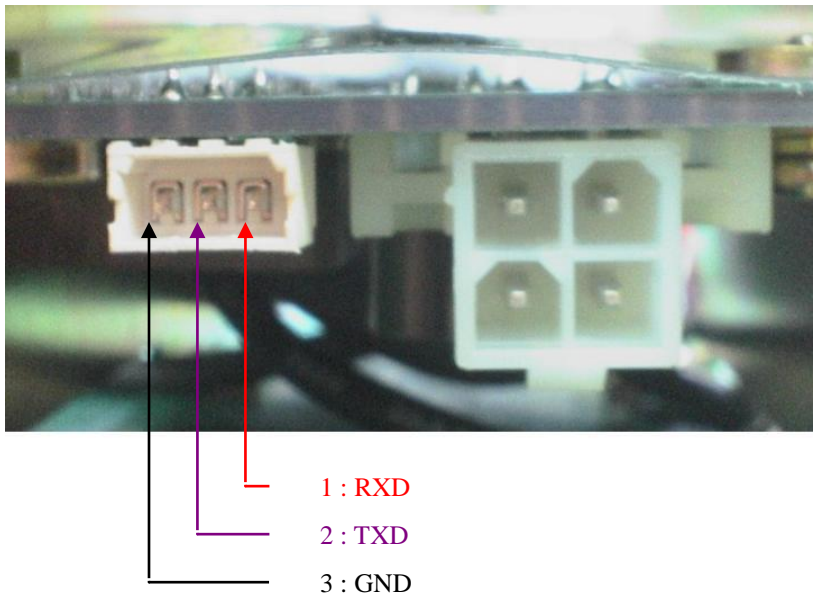

Pin No	INDEX	Remark (As of CMT-1000)
1	RXD	Receive
2	TXD	Transmit
3	GND	S.G

. Communication Method

- Asynchronous, Half duplex.

- Baud Rate : 9600, 19200BPS (Default : 9600BPS)



<b>Doc No</b>	<b>CMT-1000 SERIES SPECIFICATION</b>	<b>REV</b>	<b>PAGE</b>	<b>DATE</b>
		C	9 OF 19	2006. 10. 31.

- Data Length : 8Bits      - Parity : None      - Stop Bit : 1Bit

#### 4.2.2 TTL model

. Part Number : 53015-1010(MOLEX), Connector number : J7

. Connect Pin Table (PCB side)

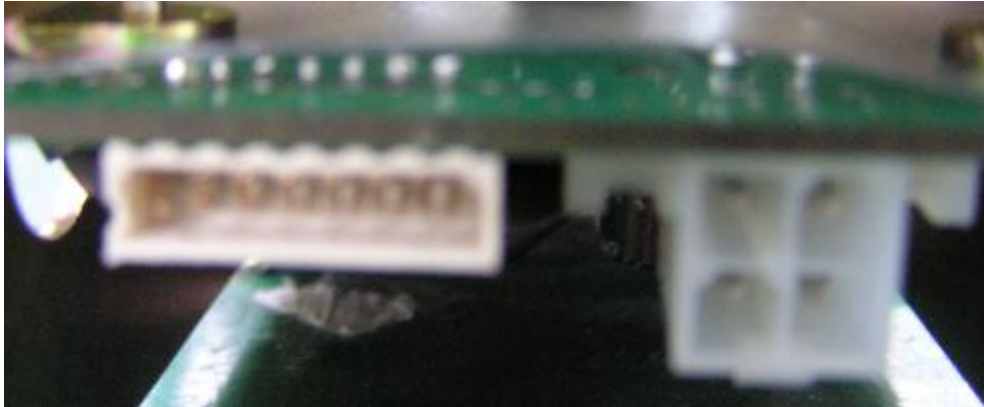

#### . Pin Description

NO	FUNCTION	DIRECTION	ACTIVE		REMARK
1	MOTOR_ENA	Input	High		Ref) “5. Technical Drawing”, “7. TTL Interface”
2	MOTOR_A	Input			
3	MOTOR_B	Input			
4	Start Sensor	Output	High	SENSOR 1	
5	Full Sensor	Output	High	SENSOR 2	
6	Common GND	Input			
7	Feed Sensor	Output	High	SENSOR 3	
8	-	-	-	-	
9	-	-	-	-	
10	-	-	-	-	

#### . D.C Motor Control Table

INPUTS			FUNCTION	REMARK
MOTOR_ENA	MOTOR_A	MOTOR_B		
H	L	High	Motor Regular Direction	Ref)“7. TTL Interface”
H	H	Low	Motor Reverse Direction	
H	MOTOR_A = MOTOR_B		Fast Motor Stop	
L	X	X	Feed Running Motor Stop	

H : HIGH

L : LOW

C : Don't Care

Doc No	CMT-1000 SERIES SPECIFICATION	REV	PAGE	DATE
		C	10 OF 19	2006. 10. 31.

## 5. Technical Drawing

< CMT-1002/ CML-1002 >

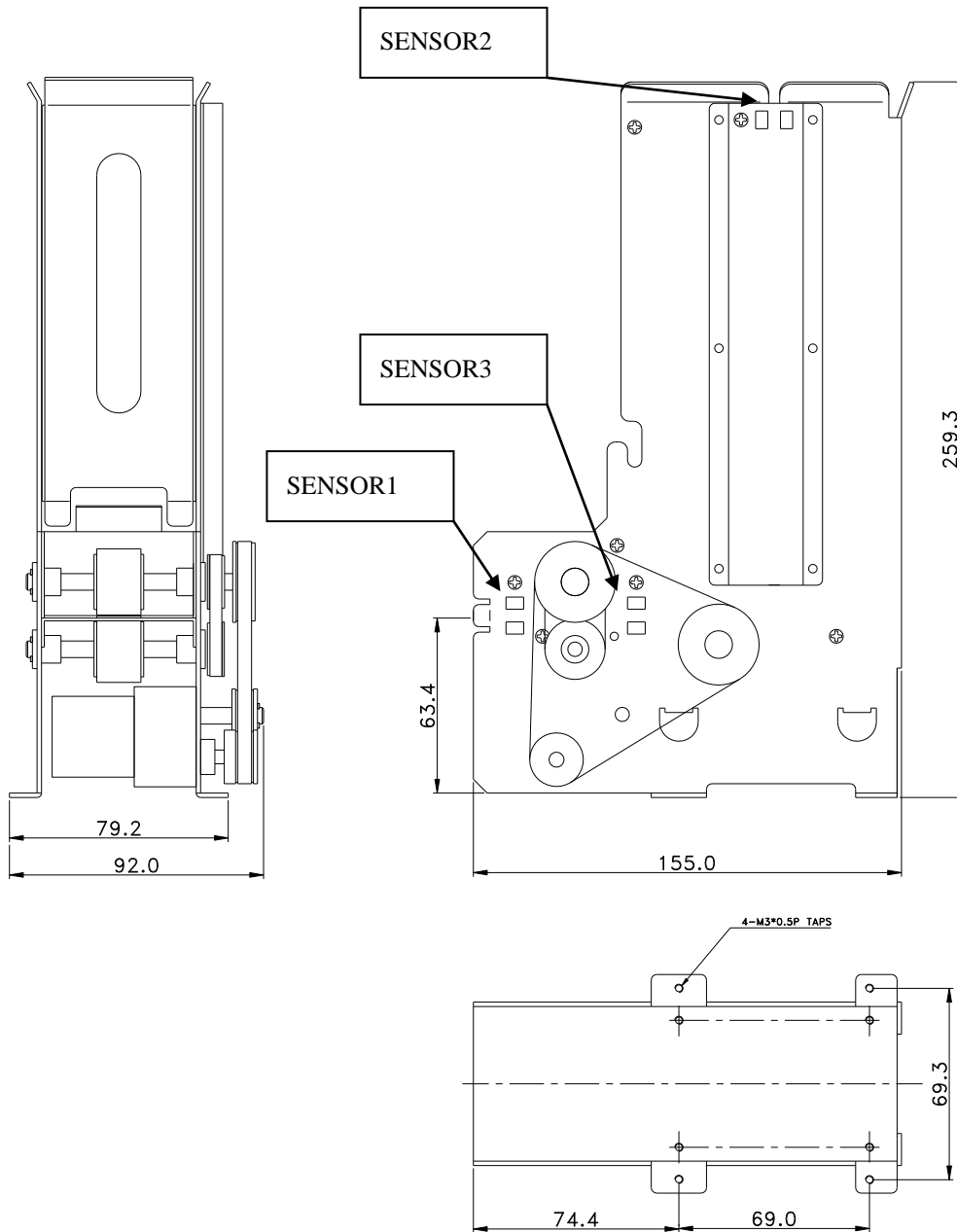

Doc No	CMT-1000 SERIES SPECIFICATION	REV	PAGE	DATE
		C	11 OF 19	2006. 10. 31.

< CMT-1003/ CML-1003 >

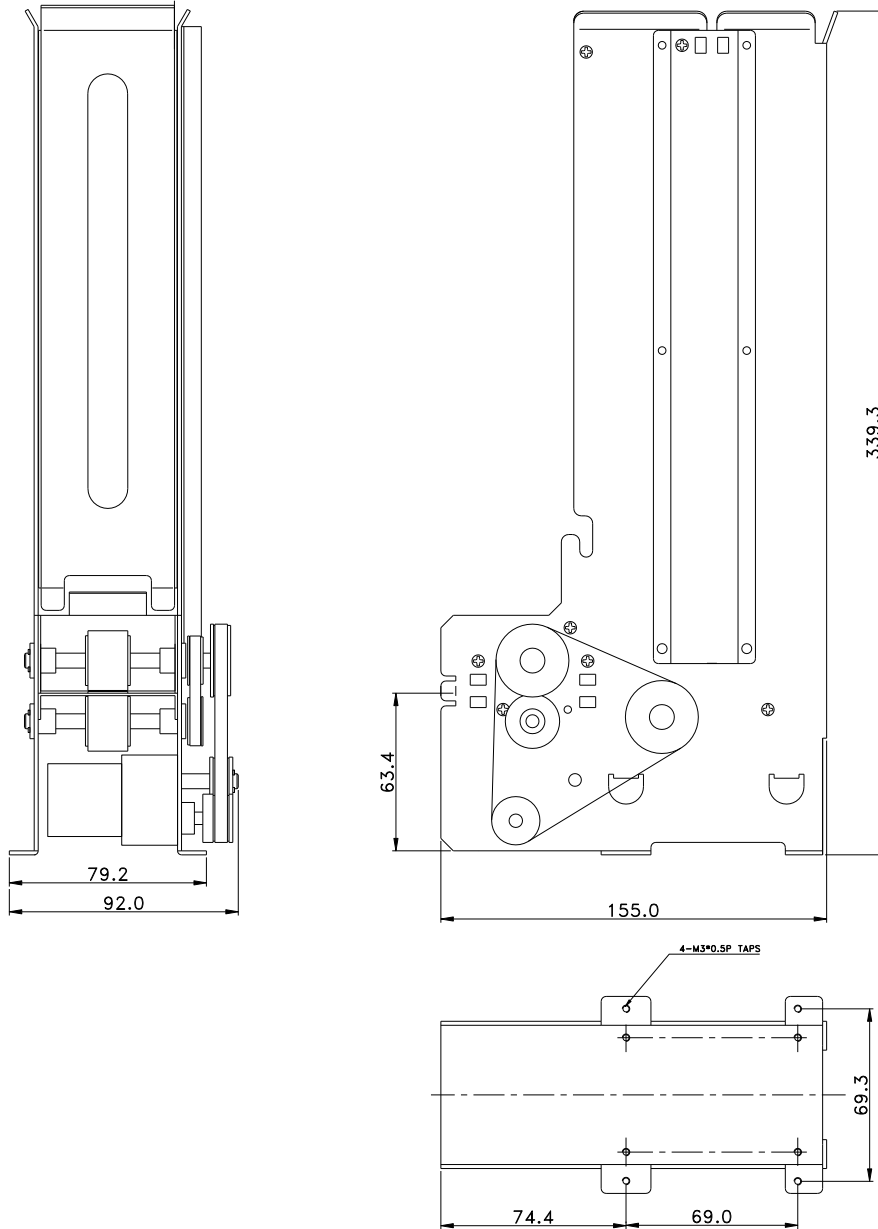

<b>Doc No</b>	<b>CMT-1000 SERIES SPECIFICATION</b>	<b>REV</b>	<b>PAGE</b>	<b>DATE</b>
		C	12 OF 19	2006. 10. 31.

## 6. RS232C Interface

### 6.1. Control Characters

NANE	Hex Value	Description
STX	02	Start of Text
ETX	03	End of Text
EOT	04	End of Transmission
ENQ	05	Enquiry
ACK	06	Positive Acknowledge
NAK	15	Negative Acknowledge
CAN	18	Cancel

### 6.2. Frame Format

Command structure

STX	Command	ETX	BCC
-----	---------	-----	-----

Response structure

STX	Status	ETX	BCC
-----	--------	-----	-----



$$BCC = STX \wedge \text{Command (or Status)} \wedge ETX$$

Doc No	CMT-1000 SERIES SPECIFICATION	REV	PAGE	DATE
		C	13 OF 19	2006. 10. 31.

### 6.3. Communication Protocol Sequence

CASE 1)

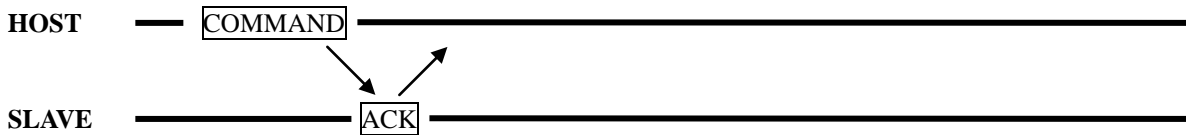

CASE 2) Request Command (0x31)

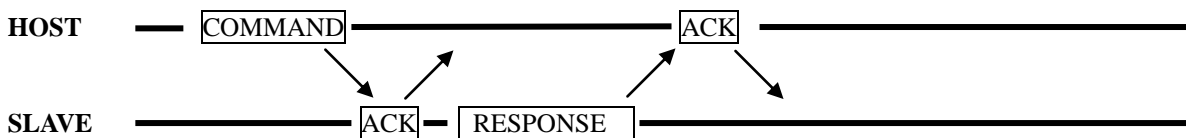

CASE 2-1)

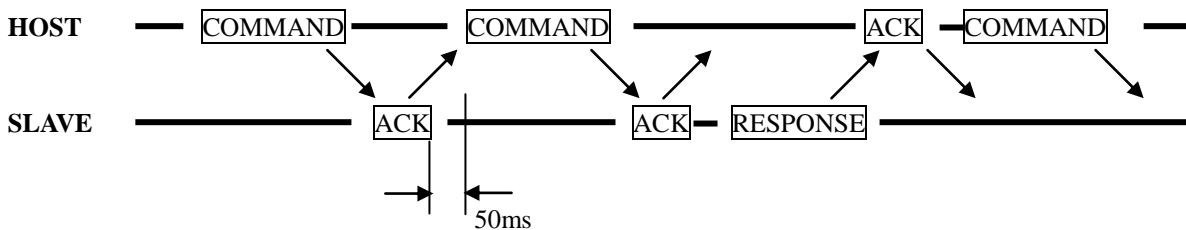

CASE 2-2)

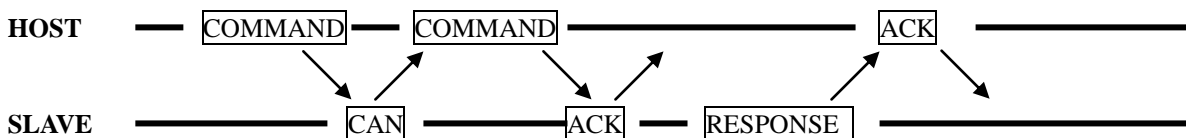
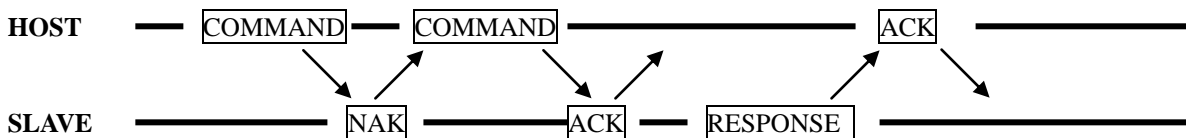

<b>Doc No</b>	<b>CMT-1000 SERIES SPECIFICATION</b>	<b>REV</b>	<b>PAGE</b>	<b>DATE</b>
		C	14 OF 19	2006. 10. 31.

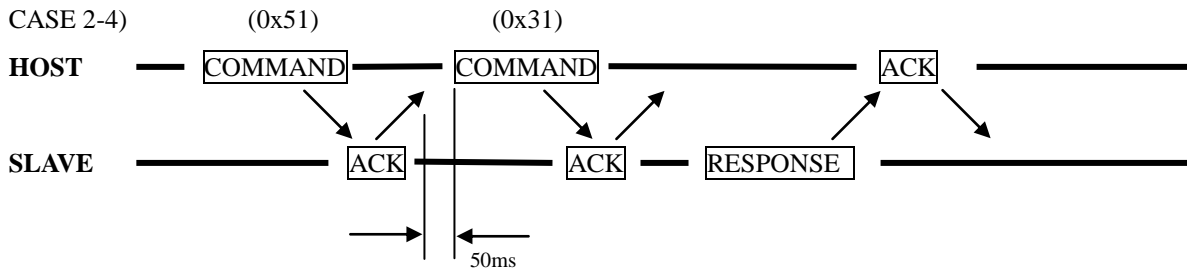

cf) To change Baud Rate , send command 50mS after receiving ACK .

<b>Doc No</b>	<b>CMT-1000 SERIES SPECIFICATION</b>	<b>REV</b>	<b>PAGE</b>	<b>DATE</b>
		C	15 OF 19	2006. 10. 31.

#### 6.4. Command Sets List

	Command	Description	Note
Clear	0x30	Error Clear	
Request	0x31	Status Request	
Card Collect	0x40	Card collecting	
Baud Rate Set	0x50	9600 BPS Setting	
	0x51	19200 BPS Setting	
Card Wait Time Set	0xF0	Non	
	0xF1	1 Sec	
	0xF2	2 Sec	
	0xF3	3 Sec	
	0xF4	4 Sec	
	0xF5	5 Sec	
	0xF6	6 Sec	
	0xF7	7 Sec	
	0xF8	8 Sec	
	0xF9	9 Sec	

<b>Doc No</b>	<b>CMT-1000 SERIES SPECIFICATION</b>	<b>REV</b>	<b>PAGE</b>	<b>DATE</b>
		C	16 OF 19	2006. 10. 31.

## 6.5. Command Details

### 6.5.1. Clear

: Clear Motor Jam bit of Status Request Command Response

※ Command Packet

STX	Command(0x30)	ETX	BCC
-----	---------------	-----	-----

### 6.5.2. Status Request.

: Host's Request for status of dispenser

Command Packet

STX	Command(0x31)	ETX	BCC
-----	---------------	-----	-----

※ Response Packet

STX	Status	ETX	BCC
-----	--------	-----	-----

※ Status Data Format ( 1 byte) – Cf) Page 10

<b>7</b>	<b>6</b>	<b>5</b>	<b>4</b>	<b>3</b>	<b>2</b>	<b>1</b>	<b>0</b>
1	0	0	0	0	0	0	0

Data		
0x80	Good	Normal
0x81	Stacker Full Sensor	Stacker full status.
0x82	Sensor #1 Detection.	Front Sensor detect Card
0x84	Sensor#2 Detection.	Collector Sensor detect Card
0x90	Motor Jam.	Card Jam
0xc0	Collector Busy	Collector is running

### 6.5.3. Card Collect.

: Collect the cards on the stacker.

※ Command Packet

STX	Command(0x40)	ETX	BCC
-----	---------------	-----	-----

### 6.5.4. Baud Rate Set.

: Baud Rate Setting.(After ACK receive, next Command should be transmitted after 50ms)

※ Command Packet (9600BPS)

STX	Command(0x50)	ETX	BCC
-----	---------------	-----	-----

※ Command Packet (19200BPS)

STX	Command(0x51)	ETX	BCC
-----	---------------	-----	-----



<b>Doc No</b>	<b>CMT-1000 SERIES SPECIFICATION</b>	<b>REV</b>	<b>PAGE</b>	<b>DATE</b>
		C	17 OF 19	2006. 10. 31.

6.5.5. Card Wait Time Set.

: After Card Collect command transmit, set waiting time until SENSOR#1, SENSOR#2 detecting.

× Command Packet

STX	Command	ETX	BCC
-----	---------	-----	-----

Command List (cf. Page 13)

<b>Doc No</b>	<b>CMT-1000 SERIES SPECIFICATION</b>	<b>REV</b>	<b>PAGE</b>	<b>DATE</b>
		C	18 OF 19	2006. 10. 31.

## 7. TTL Interface

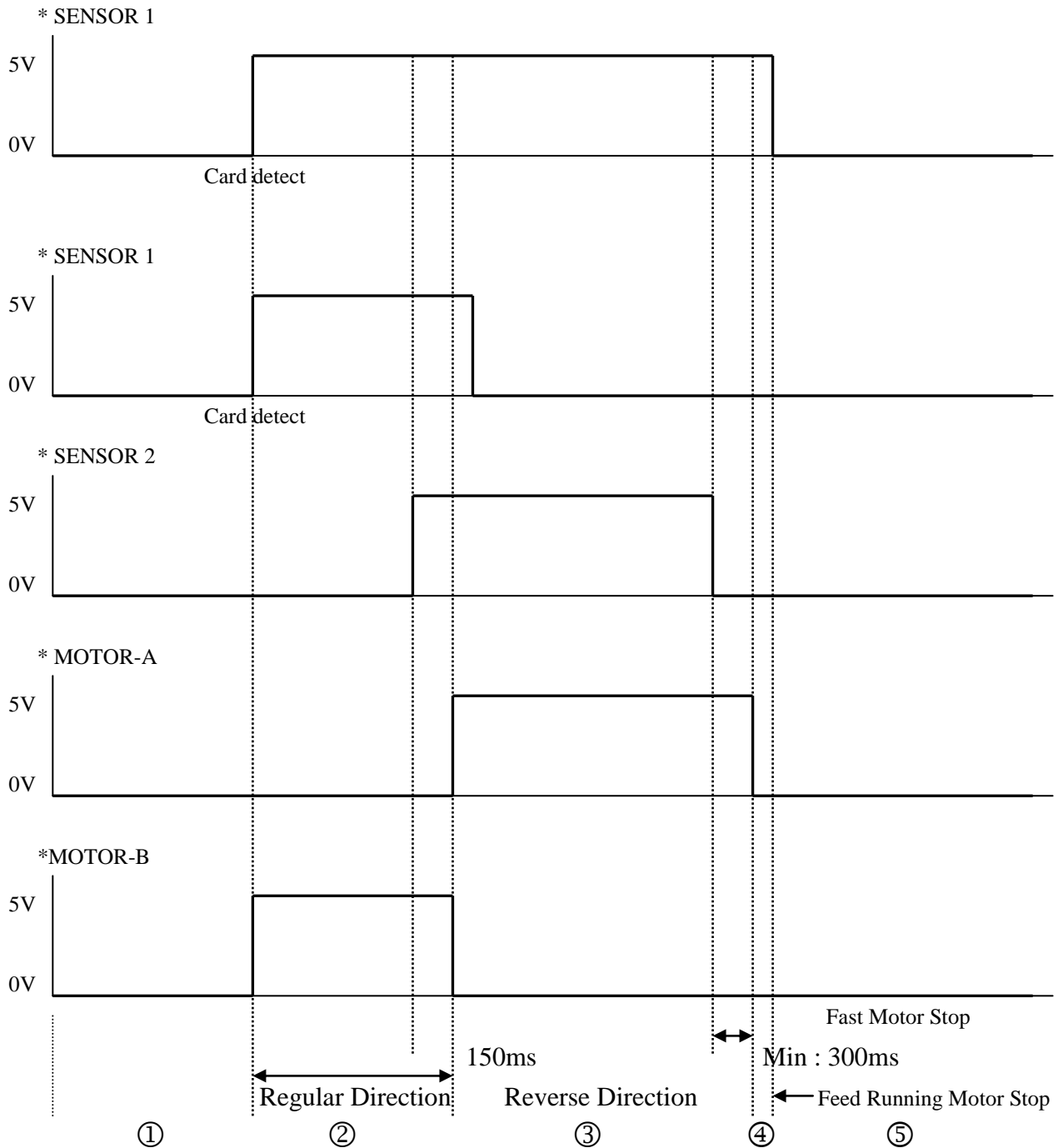

Doc No	CMT-1000 SERIES SPECIFICATION	REV	PAGE	DATE
		C	19 OF 19	2006. 10. 31.

- ① Dispenser Stand-by status.
- ② Detect the SENSOR 1, and then Motor Run
- ③ After Max 150mSec from detecting the SENSOR 2, run Motor to reverse direction
- ④ After card moved out of SENSOR 2, Motor run for Min300ms.
- ⑤ Stand-by status after 1 card collection.

EX1) RS232 Control Example

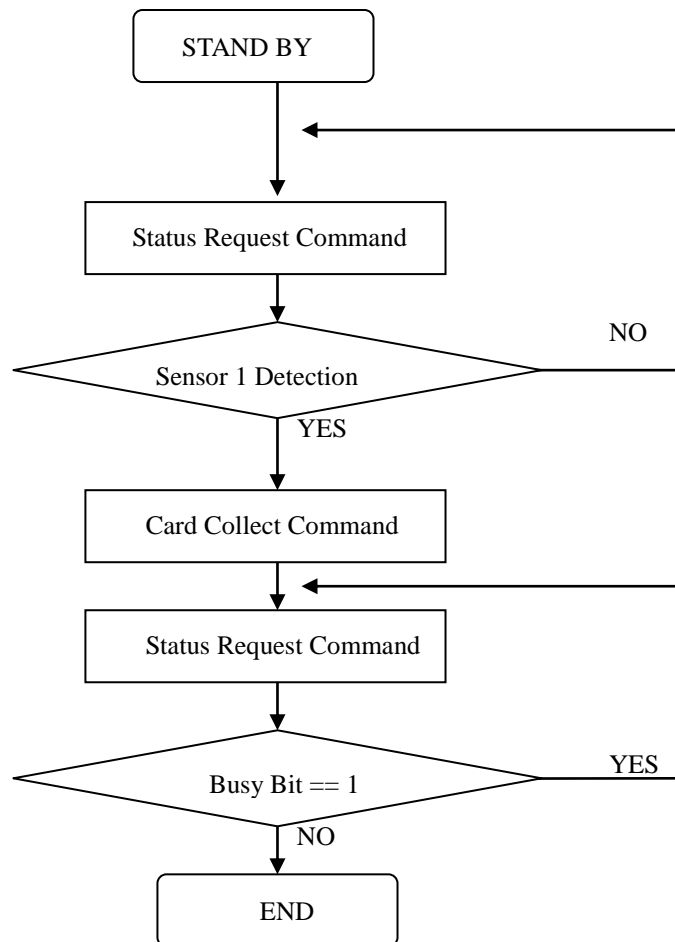

Doc No	CMT-1000 SERIES SPECIFICATION	REV	PAGE	DATE
		C	20 OF 19	2006. 10. 31.

EX 2) TTL Control Example

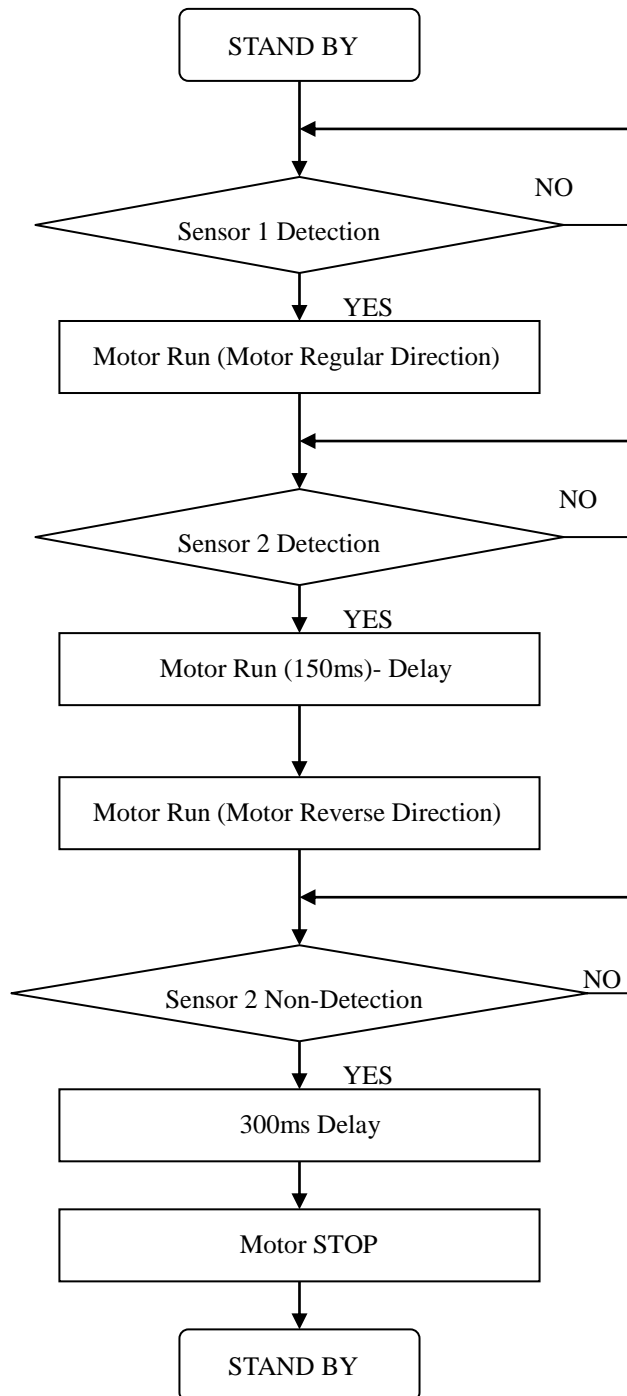

<b>Doc No</b>	<b>CMT-1000 SERIES SPECIFICATION</b>	<b>REV</b>	<b>PAGE</b>	<b>DATE</b>
			C	21 OF 19