



Ingeniería Electrónica
SMART IDENT

CARD DISPENSER MACHINE

Specifications

User Manual

KYT-4600 Rev. C

Doc No	KYT-46XXSeries SPECIFICATION	REV	PAGE	DATE
			c	2 OF 32

KYT-46XXSeries

Four Stacker Card Dispenser

Doc No	KYT-46XXSeries SPECIFICATION	REV	PAGE	DATE
		c	4 OF 32	2010. 12.31.

MODEL NAME INFORMATION

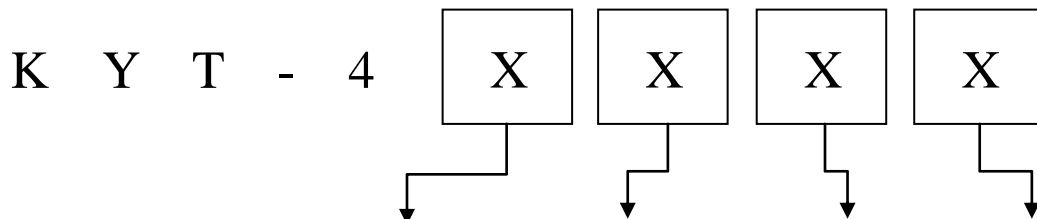

INTERFACE	FUNCTION	TYPE	CAPACITY	THICKNESS	OPTION
RS-232C	4: DISPENSER	6: FOUR STACKER	1: 100 PCS x 4 (STACKER TYPE) 2: 200 PCS x 4 3: 300 PCS x 4 4: 500 PCS x 4	1: 0.2T 2: 0.38T 3: 0.5T 4: 0.76T 5: 0.84T 6: 1.0T	S: STACKER C: CARTRIDGE

Doc No	KYT-46XXSeries SPECIFICATION	REV	PAGE	DATE
			c	5 OF 32

C O N T E N T S

1. Overview
2. Features
3. Specification
4. Block Diagram
5. I/O port definition
6. Interface
7. Protocol
8. Flow chart
9. Technical Drawing.

Doc No	KYT-46XXSeries SPECIFICATION	REV	PAGE	DATE
		C	6 OF 32	2010. 12.31.

1. Overview

Card Dispenser KYT-4XXX Series with clutch system to prevent 2 cards from being issued, has very compact and robust mechanism, which leads to high reliability and easy-to-do maintenance.

It is easy to apply KYT-4XXX to Card Vending Machine and other terminal products, bring price competitiveness to Users.

2. Features

- 1) RS-232 C Interface
- 2) Four Stackers Card Dispenser
 - Four different cards dispensing by one unit.
- 3) Four different cards loading with four cartridge
- 4) Max 2,000 cards capacity with Four cartridge(0.76T card)
- 5) Card Capture Function
 - Error cards are to be captured into Error card bin.
- 6) If error occur while dispensing the card, next Stacker can operate
 - allowing non-stop operation (Stacker #1 → Stacker #2 → Stacker #3 → Stacker #4)
- 7) Easy to control card stop, card dispensing and card capture by microprocessor
- 8) Intelligent monitoring all the process
 - Cards empty and card low level warning function with its own microprocessor
- 9) Automatic Baud Rate change during RS-232C Interface (9,600 BPS to 38,400 BPS)
- 10) The size of the product is compact in consideration of its loading capacity and 4 different cards loading

Doc No	KYT-46XXSeries SPECIFICATION	REV	PAGE	DATE
		c	7 OF 32	2010. 12.31.

3. Specification

MODEL	KYT-461X,462X	KYT-463X,464X
Dimensions	Refer to Page 31	Refer to Page 32
Dispensing speed (sec)	1.5	2
Applicable Cards	Phone Card, Credit, Debit, Pre-paid, I.C, R/F, Parking Card	
Card thickness (mm)	0.22 ~ 1.0	
Interface	RS-232C	
Supply voltage & Current consumption	Without Load: DC 24V – 200mA. With Load: DC 24V – 2.0A.	
Operating temperature	0°C ~ 40°C	
Operating humidity	0 % ~ 96 % RH (without condensation)	
Operation locus	In the cabinet	

Doc No	KYT-46XXSeries SPECIFICATION	REV	PAGE	DATE
		c	8 OF 32	2010. 12.31.

4. Block Diagram

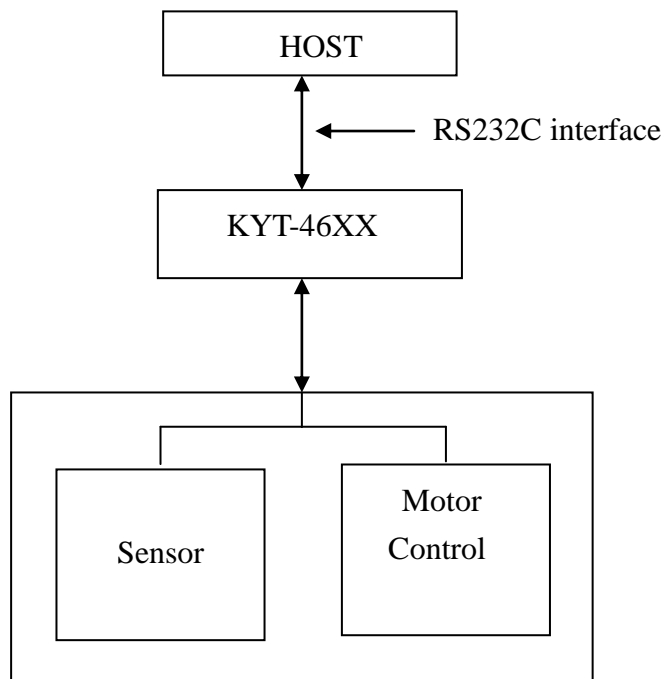

Doc No	KYT-46XXSeries SPECIFICATION	REV	PAGE	DATE
		c	9 OF 32	2010. 12.31.

5. I/O Port Definition

5.1. DC Power Connector (J3)

5.1.1. Header: 5566-04A1 (MOLEX)

5.1.2. Power Connector Pin Table

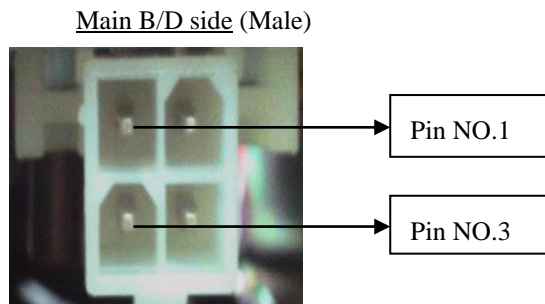

Pin NO	Signal Name	Cable color	Direction
1	GND(+24V)	Black	Input
2	Non-use		
3	+24V	Yellow	
4	Non-use		

Doc No	KYT-46XXSeries SPECIFICATION	REV	PAGE	DATE
		c	10 OF 32	2010. 12.31.

5.2 Connection

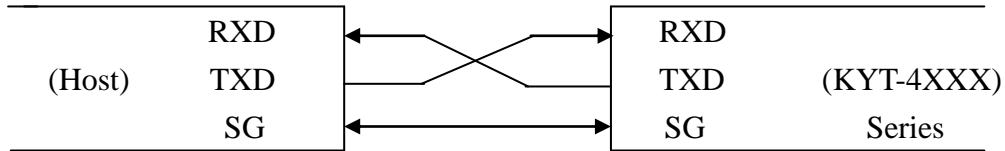

※RS232C Pin Number (P2)

Pin No	INDEX	Remark
2	RXD	Receive
3	TXD	Transmit
5	SG	Signal Ground

※ RS-232C 9P(Female)

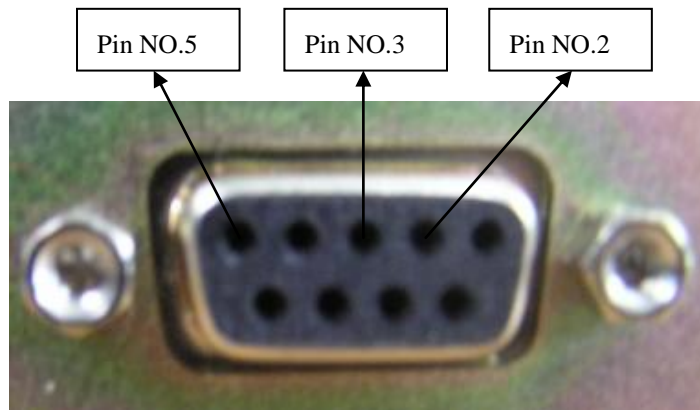

RDED-9SE-LNA (HIROSE)

Doc No	KYT-46XXSeries SPECIFICATION	REV	PAGE	DATE
		c	11 OF 32	2010. 12.31.

DIP SWITCH SETTING

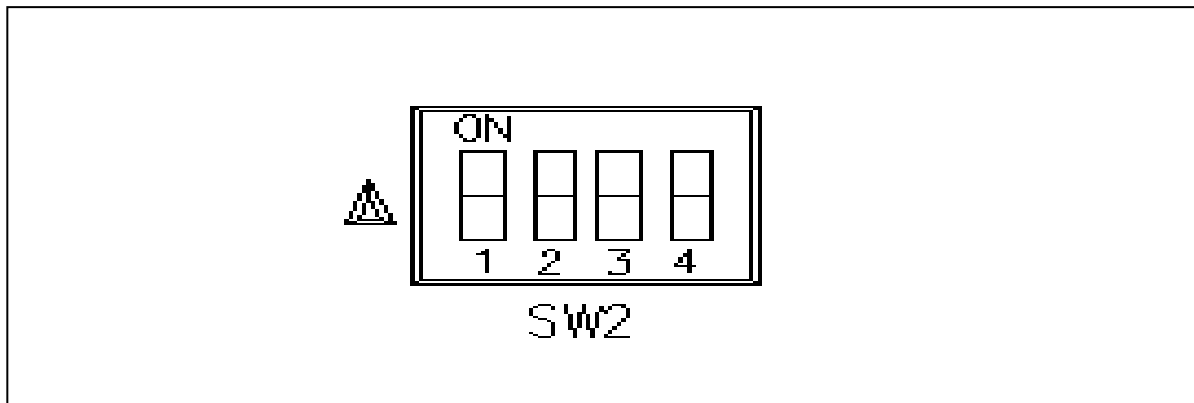

PIN NO. 1 select the F'W download mode.

Status	Description	Remark
ON	F'W download mode	
OFF	Action mode	Default

PIN NO. 2 select the initialization mode.

Status	Description	Remark
ON	When turning the power supply on, the motor don't move.	
OFF	When turning the power supply on, the motor move.	Default

PIN NO. 3 and PIN NO. 4 use setting of communication speed in the terminal.

PIN NO. 3	PIN NO. 4	Communication speed	Remark
OFF	OFF	9600 BPS	Default
ON	OFF	19200 BPS	
OFF	ON	38400 BPS	

Doc No	KYT-46XXSeries SPECIFICATION	REV	PAGE	DATE
		c	12 OF 32	2010. 12.31.

6. Interface

< Command >

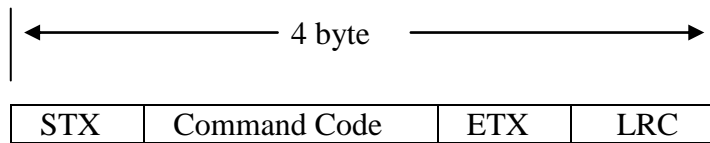

LRC: Longitudinal Redundancy Check– Calculated by EX-OR all Characters from STX to ETX inclusive.

< Response >

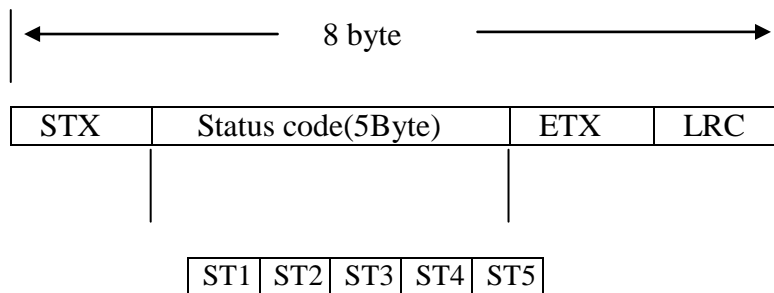

Doc No	KYT-46XXSeries SPECIFICATION	REV	PAGE	DATE
		c	13 OF 32	2010. 12.31.

6.1. Status Check bit

< ST 1 Format >

✕	7	6	5	4	3	2	1	0
1	Always	Busy	* Rfu	* Rfu	Stacker #4 Empty	Stacker #3 Empty	Stacker #2 Empty	Stacker #1 Empty
0	Non-use	Ready	* Rfu	* Rfu	Stacker #4 Good	Stacker #3 Good	Stacker #2 Good	Stacker #1 Good

< ST 2 Format >

✕	7	6	5	4	3	2	1	0
1	Always	* Rfu	* Rfu	* Rfu	Stacker #4 Warning	Stacker #3 Warning	Stacker #2 Warning	Stacker #1 Warning
0	Non-use	* Rfu	* Rfu	* Rfu	Stacker #4 Good	Stacker #3 Good	Stacker #2 Good	Stacker #1 Good

Doc No	KYT-46XXSeries SPECIFICATION	REV	PAGE	DATE
		C	14 OF 32	2010. 12.31.

< ST 3 Format >

✕	7	6	5	4	3	2	1	0
1	Always	* Rfu	Feeder Sensor 6 Detection	Feeder Sensor 5 Detection	Feeder Sensor 4 Detection	Feeder Sensor 3 Detection	Feeder Sensor 2 Detection	Feeder Sensor 1 Detection
0	Non-use	* Rfu	Non- Detection	Non- Detection	Non- Detection	Non- Detection	Non- Detection	Non- Detection

< ST 4 Format >

✕	7	6	5	4	3	2	1	0
1	Always	* Rfu	* Rfu	* Rfu	Stacker #4 Finish Sensor Detection	Stacker #3 Finish Sensor Detection	Stacker #2 Finish Sensor Detection	Stacker #1 Finish Sensor Detection
0	Non-use	* Rfu	* Rfu	* Rfu	Non - Detection	Non - Detection	Non - Detection	Non - Detection

Doc No	KYT-46XXSeries SPECIFICATION	REV	PAGE	DATE
		c	15 OF 32	2010. 12.31.

< ST 5 Format >

X	7	6	5	4	3	2	1	0
1	Always	* Rfu.	Motor#6 Error	Motor#5 Error	Motor#4 Error	Motor#3 Error	Motor#2 Error	Motor#1 Error
0	Non-use	* Rfu	Motor#6 Good	Motor#5 Good	Motor#4 Good	Motor#3 Good	Motor#2 Good	Motor#1 Good

*** Rfu: Reserve for future use.**

※ Stacker Card Loading Low Warning

Stacker Status	Detail
‘Stacker Good’	Normal status
‘Stacker Warning’	Too few cards loading ¹⁾
‘Stacker Empty’	No cards in stacker

1) The stacker status is detected by the sensor behind the stacker. The number of cards can be changed by changing Sensor position.

- High position : in case of less than 60 cards
- Middle position : in case of less than 40 cards
- Low position : in case of less than 20 cards (Default position in production line)

※ Motor Error

- Motor Fail, Card Jam, Sensor Error in operation.

※ Busy

- Busy signal is detected only when it is in operation.

Doc No	KYT-46XXSeries SPECIFICATION	REV	PAGE	DATE
		c	16 OF 32	2010. 12.31.

★ For information on sensors locations

- KYT-461X,462X

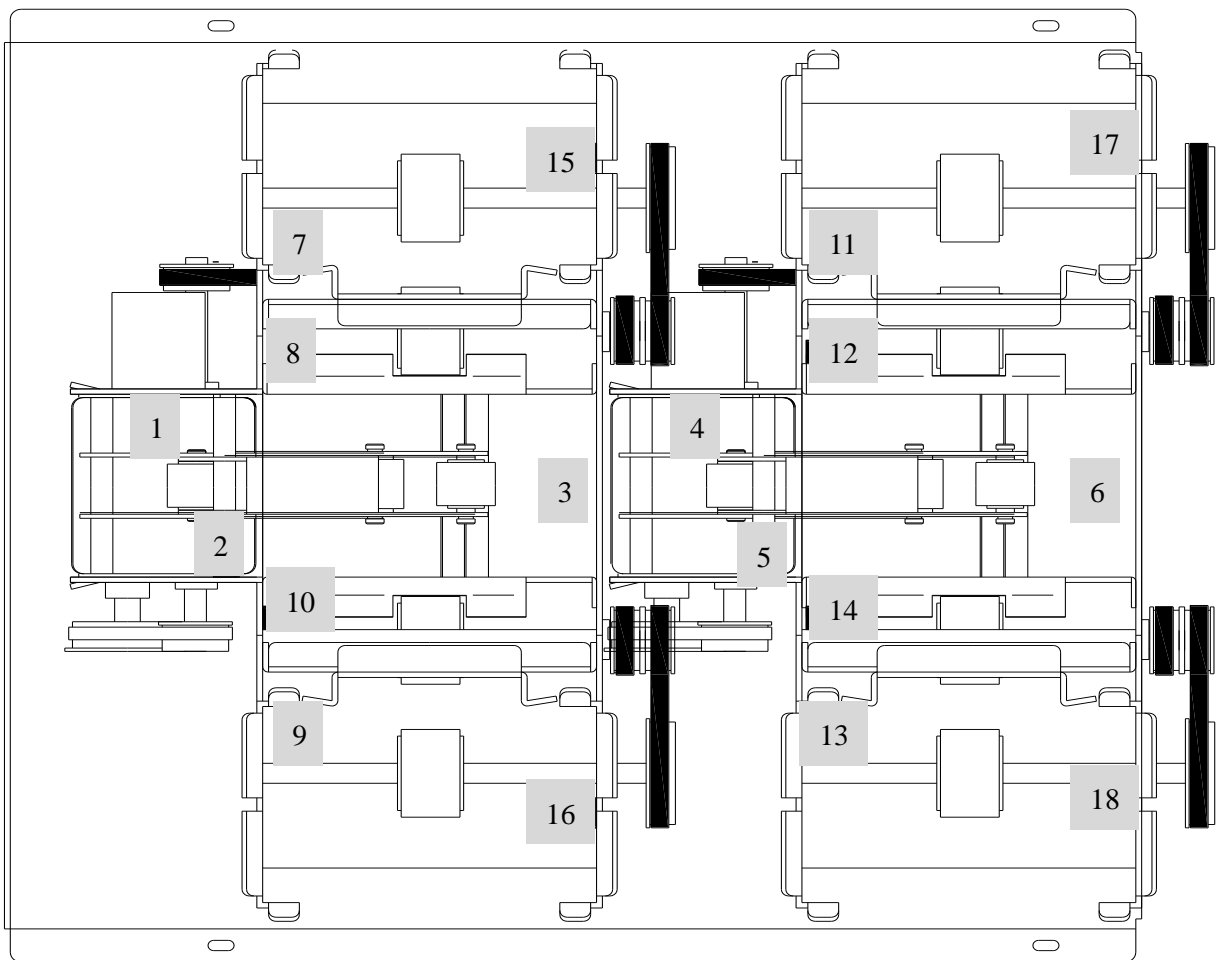

1	Feeder Sensor 1	10	Stacker #2 Finish Sensor
2	Feeder Sensor 2	11	Stacker #3 Empty Sensor
3	Feeder Sensor 3	12	Stacker #3 Finish Sensor
4	Feeder Sensor 4	13	Stacker #4 Empty Sensor
5	Feeder Sensor 5	14	Stacker #4 Finish Sensor
6	Feeder Sensor 6	15	Stacker #1 Warning Sensor
7	Stacker #1 Empty Sensor	16	Stacker #2 Warning Sensor
8	Stacker #1 Finish Sensor	17	Stacker #3 Warning Sensor
9	Stacker #2 Empty Sensor	18	Stacker #4 Warning Sensor

Doc No	KYT-46XXSeries SPECIFICATION	REV	PAGE	DATE
		c	17 OF 32	2010. 12.31.

- KYT-463X,464X

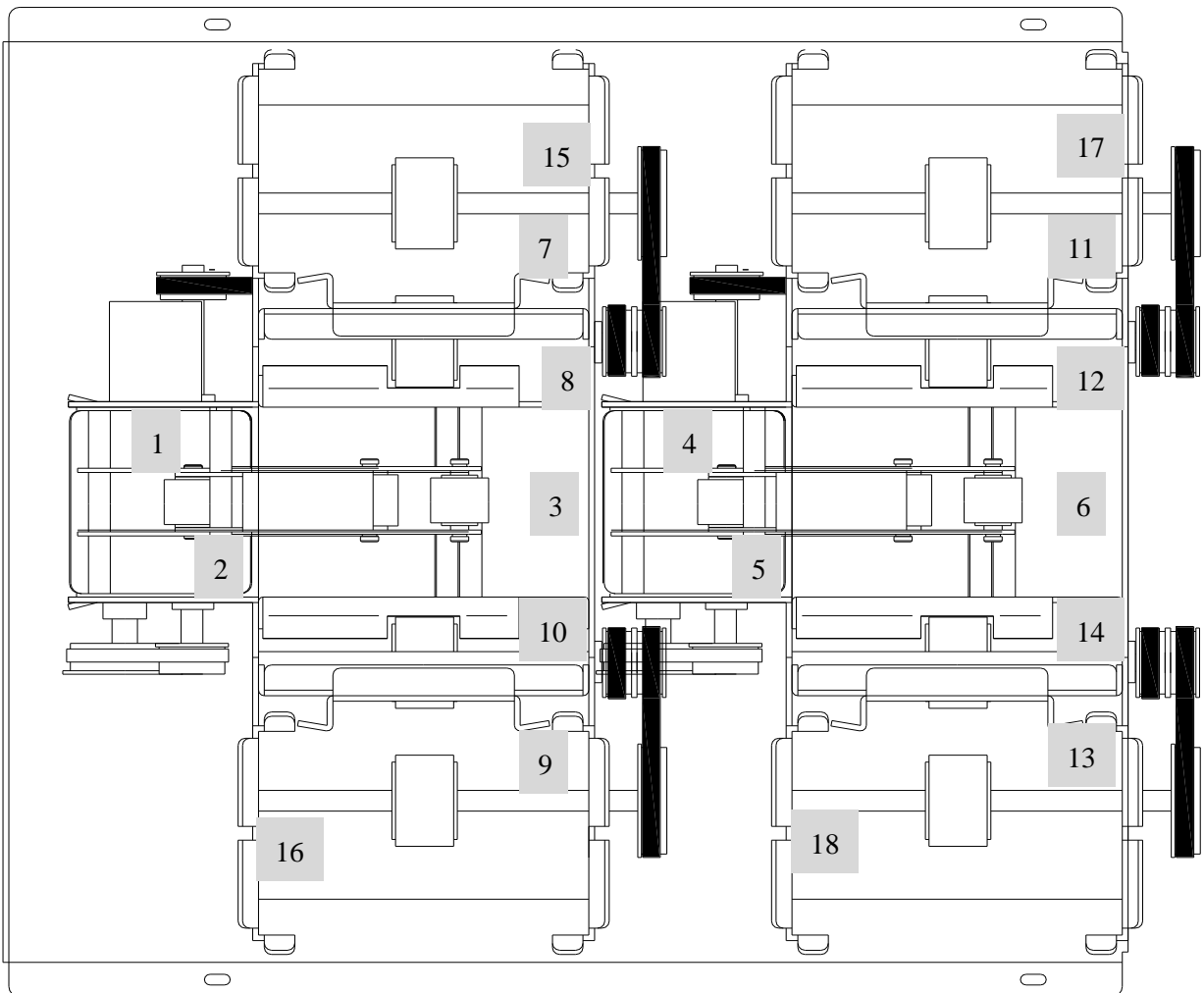

1	Feeder Sensor 1	10	Stacker #2 Finish Sensor
2	Feeder Sensor 2	11	Stacker #3 Empty Sensor
3	Feeder Sensor 3	12	Stacker #3 Finish Sensor
4	Feeder Sensor 4	13	Stacker #4 Empty Sensor
5	Feeder Sensor 5	14	Stacker #4 Finish Sensor
6	Feeder Sensor 6	15	Stacker #1 Warning Sensor
7	Stacker #1 Empty Sensor	16	Stacker #2 Warning Sensor
8	Stacker #1 Finish Sensor	17	Stacker #3 Warning Sensor
9	Stacker #2 Empty Sensor	18	Stacker #4 Warning Sensor

Doc No	KYT-46XXSeries SPECIFICATION	REV	PAGE	DATE
		c	18 OF 32	2010. 12.31.

6.2. Transmission Control Characters

Character	Hex Value	Description
STX	02	Start of Text
ETX	03	End of Text
ENQ	05	Enquiry Character
ACK	06	Acknowledge Character
NAK	15	Negative Acknowledge Character
CAN	18	Cancel Character

6.3. Communication

RS-232C Interface

Baud Rate:

- 9600 BPS (default)

-19200 BPS

-38400 BPS

Data bit: 8 bit

Stop bit: 1 bit

Parity bit: None

Doc No	KYT-46XXSeries SPECIFICATION	REV	PAGE	DATE
		c	19 OF 32	2010. 12.31.

7. Protocol

7.1 Enquiry

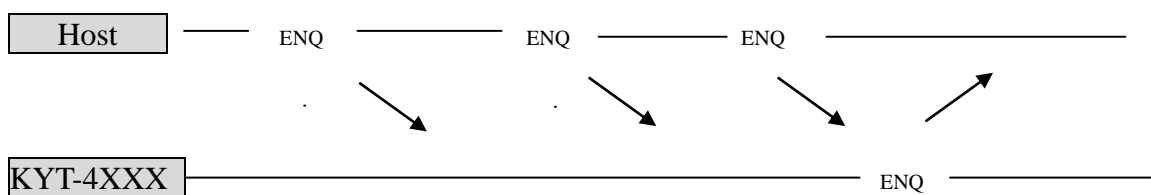

Error signal is sent if there is no response after Host transmits ENQ 3 times.

7.2. General Sequence

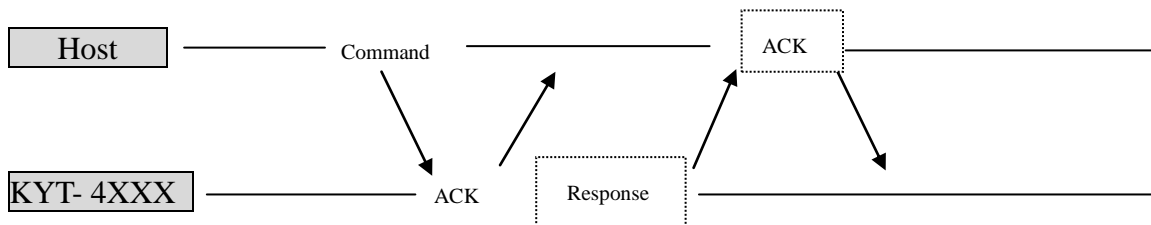

There are 2 types of sequence. First, when Command received, KYT-4XXX checks Command and sends ACK. Then, KYT-4XXX runs, and as soon as Command executed, it receives ACK after transmitting Response. Second, as soon as KYT-4XXX receives Command, it transmits ACK and starts to run, but it does not send Response.

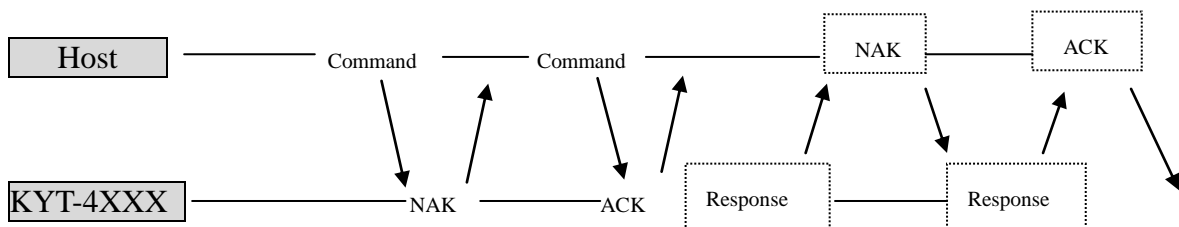

Above is reference sequence in case of the transmission and the sending of abnormal Commands and Responses.

Doc No	KYT-46XXSeries SPECIFICATION	REV	PAGE	DATE
		c	20 OF 32	2010. 12.31.

7.3. RS-232C Control Command

COMMAND DETAIL

Item	Command	Description	Note
CLEAR	0x30	Error Clear	
STATUS	0x31	Get Status Request	
SETTING	0x50	Set Baud Rate	9600 BPS
	0x51	Set Baud Rate	19200 BPS
	0x52	Set Baud Rate	38400 BPS
ROM VER.	0x60	Get Firmware Version	
DISPENSING	0x70	Stacker #1 Dispensing	
	0x71	Stacker #2 Dispensing	
	0x72	Stacker #3 Dispensing	
	0x73	Stacker #4 Dispensing	
	0x74	Automatic Dispensing	
	0x75	Stacker #1 Dispensing and Exit Standby	
	0x76	Stacker #2 Dispensing and Exit Standby	
	0x77	Stacker #3 Dispensing and Exit Standby	
	0x78	Stacker #4 Dispensing and Exit Standby	
	0x79	Automatic Dispensing and Exit Standby	
MOVE	0x80	Move to the inside	
	0x81	Move to the outside	
	0x82	Move to the outside with Solenoid1	
	0x83	Move to the Bin	
	0x84	Move Stop	
	0x85	Move to the outside with Solenoid2	
	0x86	Move to the outside and Exit Standby	

Doc No	KYT-46XXSeries SPECIFICATION	REV	PAGE	DATE
		c	21 OF 32	2010. 12.31.

7.3.1. Function

◆ Error Clear

- Initializing parameters

Ex) Error bit initialization

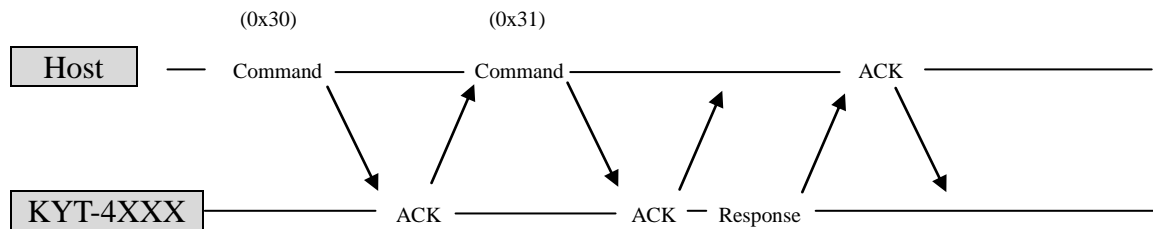

“STX” Command only can be used without sending “ENQ” part for communication. If Error Clear Command (0x30) is transmitted, KYT-4XXX just sends ACK as a Response. To check if dispenser is cleared, send Get Status Request Command (0x31).

◆ Get Status Request

- Host’s request for Status of Dispenser.

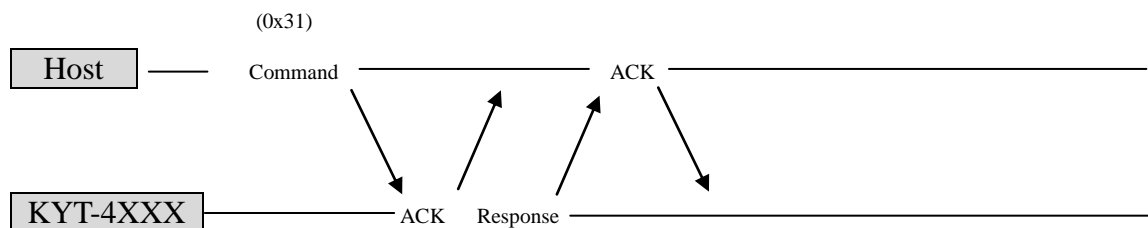

When Command (0x31) is transmitted, ACK & Response are transmitted to Terminal.

Doc No	KYT-46XXSeries SPECIFICATION	REV	PAGE	DATE
		c	22 OF 32	2010. 12.31.

◆ Stacker #1 Dispensing

- Dispensing card from Stacker.

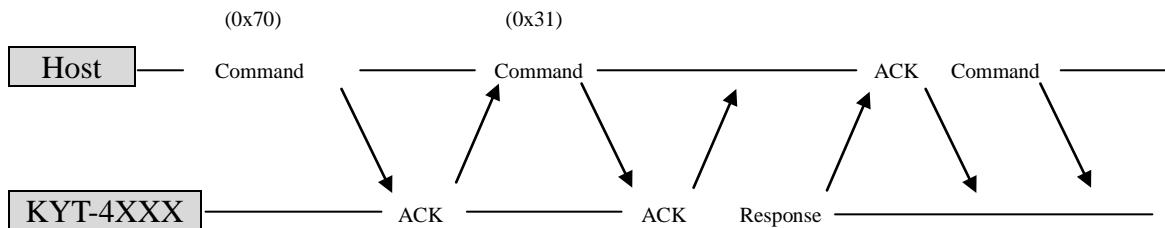

Before escaping from Stacker, Move Stop Command (0x84) can't use.

◆ Stacker #2 Dispensing

- Dispensing card from Stacker.

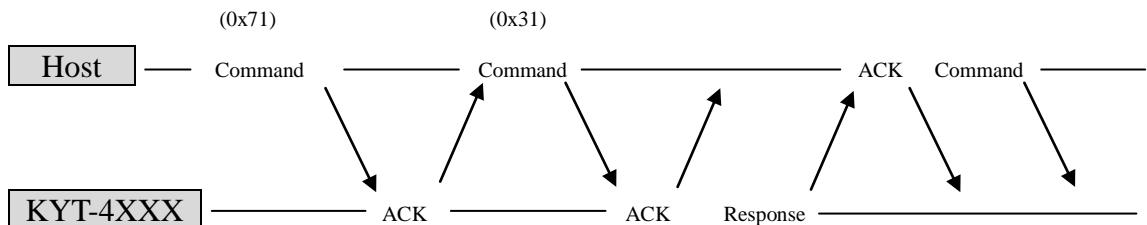

Before escaping from Stacker, Move Stop Command (0x84) can't use.

Doc No	KYT-46XXSeries SPECIFICATION	REV	PAGE	DATE
		c	23 OF 32	2010. 12.31.

◆ Stacker #3 Dispensing

- Dispensing card from Stacker.

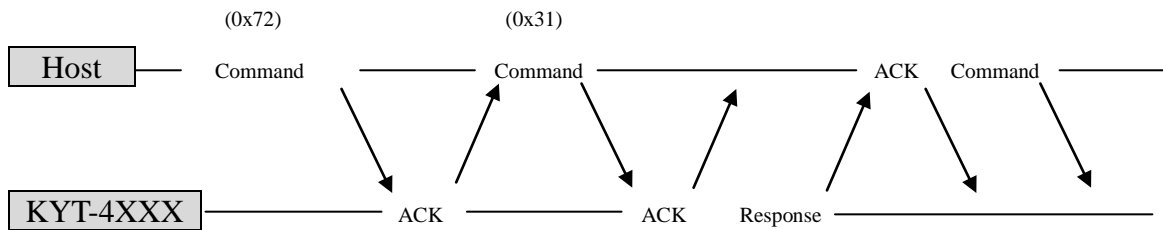

Before escaping from Stacker, Move Stop Command (0x84) can't use.

◆ Stacker #4 Dispensing

- Dispensing card from Stacker.

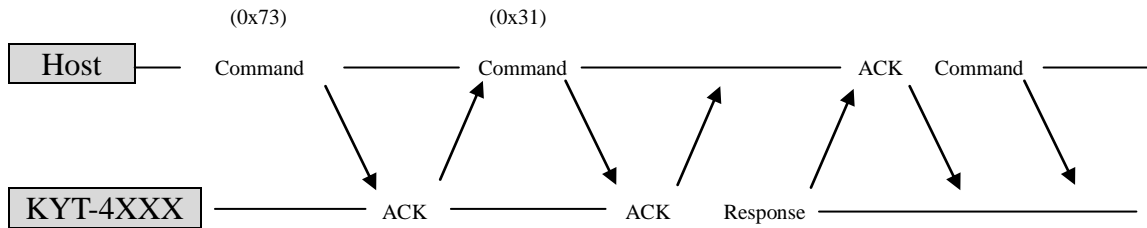

Before escaping from Stacker, Move Stop Command (0x84) can't use.

Doc No	KYT-46XXSeries SPECIFICATION	REV	PAGE	DATE
		c	24 OF 32	2010. 12.31.

◆ Automatic Dispensing

- When the card is being piled up in all stacker, until stacker #4 operates sequentially from stacker #1.

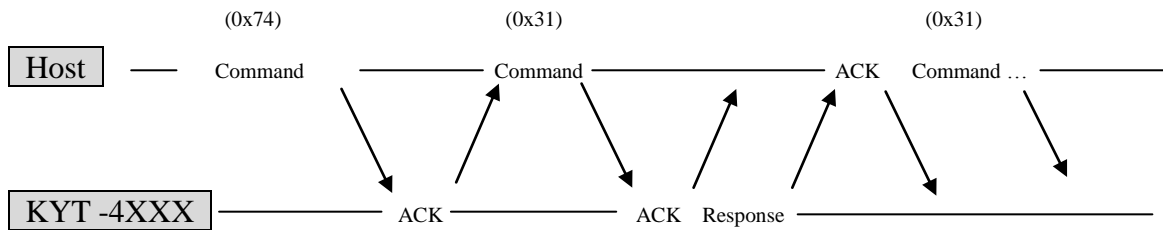

Before escaping from Stacker, Move Stop Command (0x84) can't use.

This Command memorizes the last dispensed Stacker. Therefore, when dispensed the next card the unit operate from that Stacker, unless the unit is reset.

◆ Stacker #1 Dispensing and Exit Standby

- Dispense the card to front and hold it at the exit roller of the unit.

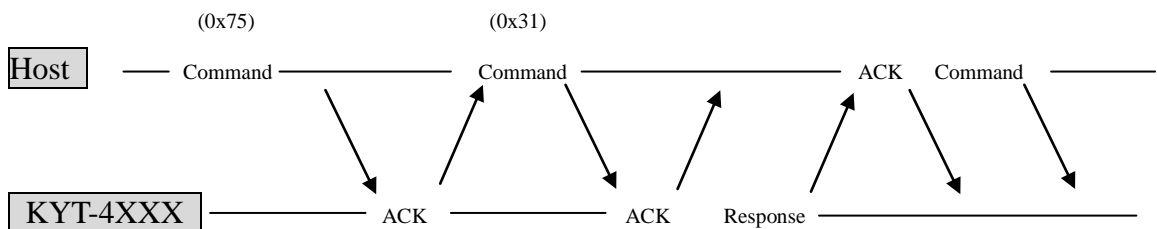

Before escaping from Stacker, Move Stop Command (0x84) can't use.

Doc No	KYT-46XXSeries SPECIFICATION	REV	PAGE	DATE
		C	25 OF 32	2010. 12.31.

◆ Stacker #2 Dispensing and Exit Standby

- Dispense the card to front and hold it at the exit roller of the unit.

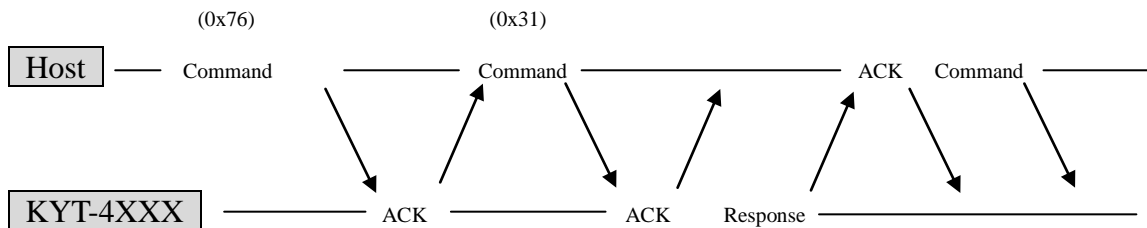

Before escaping from Stacker, Move Stop Command (0x84) can't use.

◆ Stacker #3 Dispensing and Exit Standby

- Dispense the card to front and hold it at the exit roller of the unit.

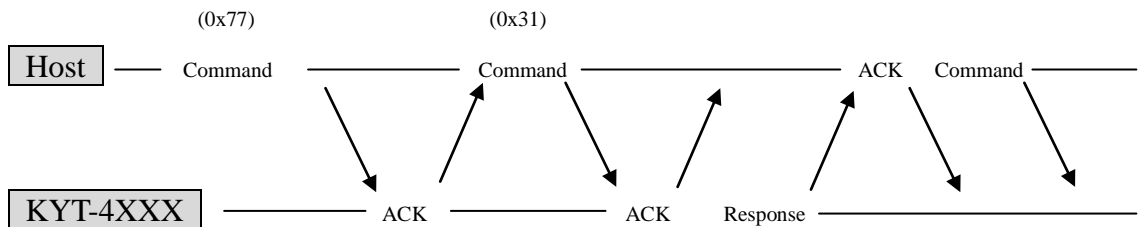

Before escaping from Stacker, Move Stop Command (0x84) can't use.

◆ Stacker #4 Dispensing and Exit Standby

- Dispense the card to front and hold it at the exit roller of the unit.

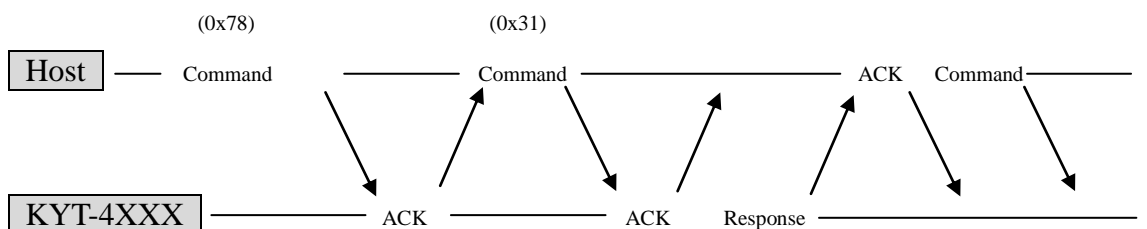

Doc No	KYT-46XXSeries SPECIFICATION	REV	PAGE	DATE
		C	26 OF 32	2010. 12.31.

Before escaping from Stacker, Move Stop Command (0x84) can't use.

◆ Automatic Dispensing and Exit Standby

- When the card is being piled up in all Stacker, until Stacker #4 operates sequentially from Stacker #1.
- Dispense the card to front and hold it at the exit roller of the unit.

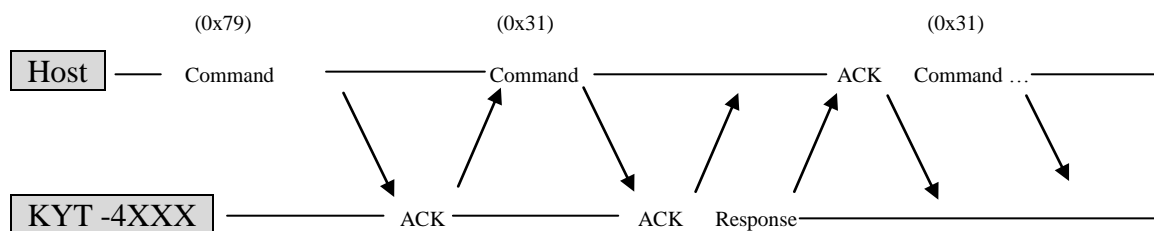

Before escaping from Stacker, Move Stop Command (0x84) can't use.

This Command memorizes the last dispensed Stacker. Therefore, when dispensed the next card the unit operate from that Stacker, unless the unit is reset.

◆ Move to the Bin

- Error cards are captured into error card bin.

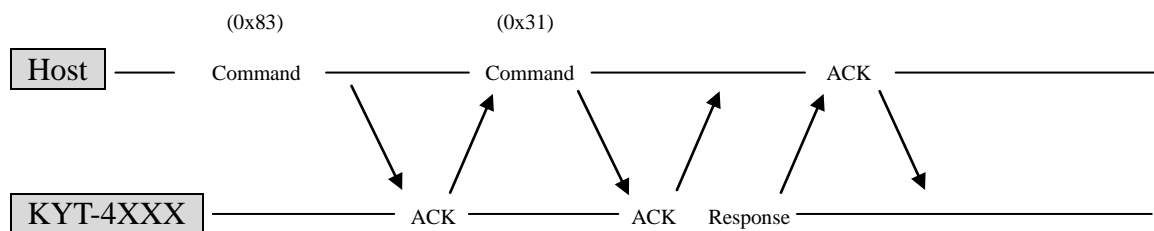

If Capture Command (0x83) is transmitted, Motor #5 operates.

If card is not detected in 2000ms, this operation stops.

Doc No	KYT-46XXSeries SPECIFICATION	REV	PAGE	DATE
		c	27 OF 32	2010. 12.31.

◆ Move Stop

- The function which stops the card.

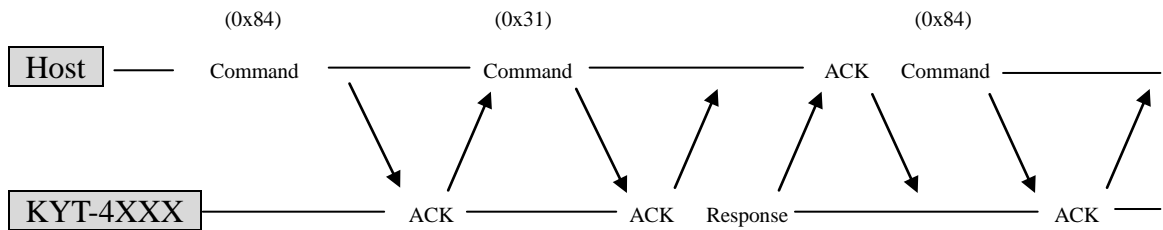

After escaping from Stacker, Move Stop Command (0x84) can use.

◆ Move to inside

- Make Motor #5 run backward to take card back to Bin.

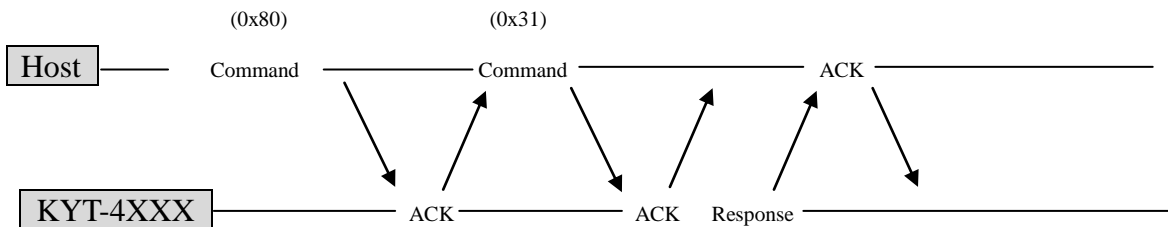

When the card is detected in the exit, the Motor #5 operates.

◆ Move to outside

- A card is sent out when the card is detected by Feeder Sensors.

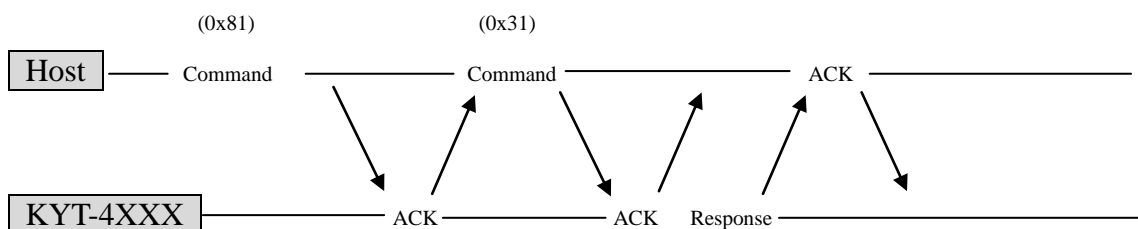

Doc No	KYT-46XXSeries SPECIFICATION	REV	PAGE	DATE
		C	28 OF 32	2010. 12.31.

If card is detected, the Motor #5 or Motor #6 operates.

◆ Move to the outside with Solenoid1

- If a card stays at dead zone, this Command forces the card to be dispensed.

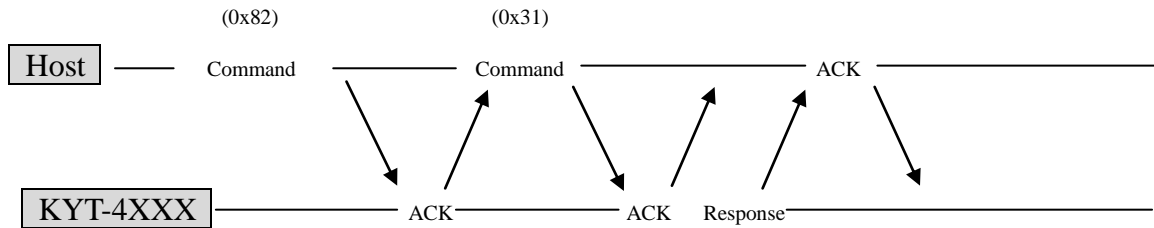

If Command (0x82) is transmitted, Motor#5 and Solenoid1 operates.

If card is not detected in 2500ms, this operation stops.

◆ Move to the outside with Solenoid2

- If a card stays at dead zone, this Command forces the card to be dispensed.

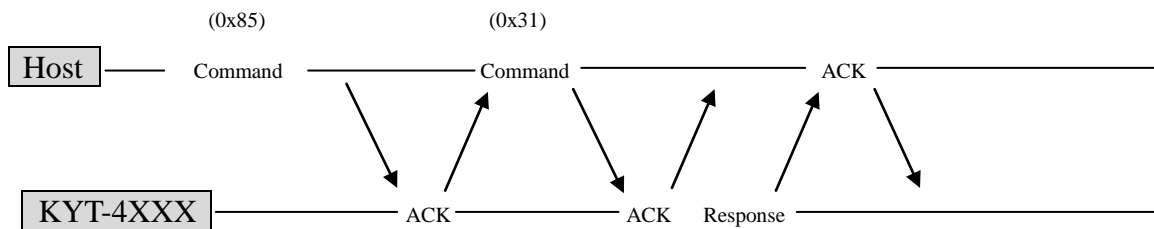

If Command (0x85) is transmitted, Motor#6 and Solenoid1 operates.

If card is not detected in 2500ms, this operation stops.

Doc No	KYT-46XXSeries SPECIFICATION	REV	PAGE	DATE
		c	29 OF 32	2010. 12.31.

◆ Baud Rate Control Command

No.	Command	Baud Rate
1	0x50	9600 BPS (Default)
2	0x51	19200 BPS
3	0x52	38400 BPS

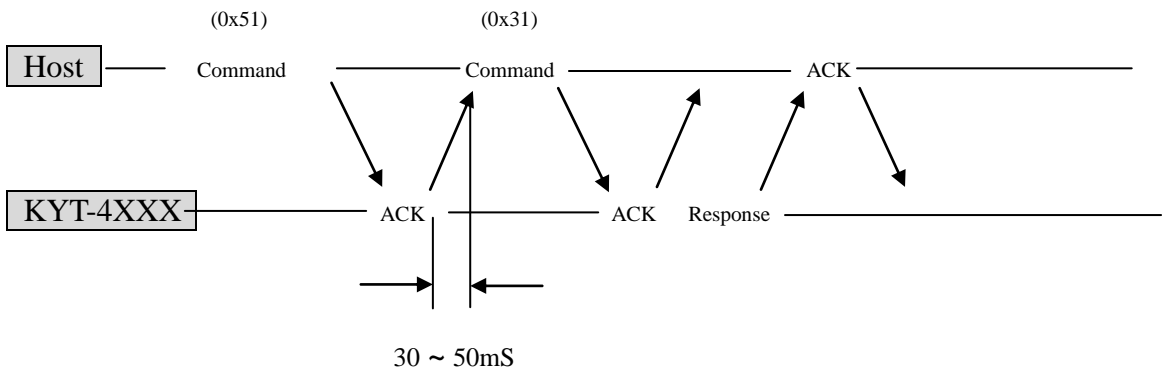

◆ Get Firmware Version

- It indicates firmware version.

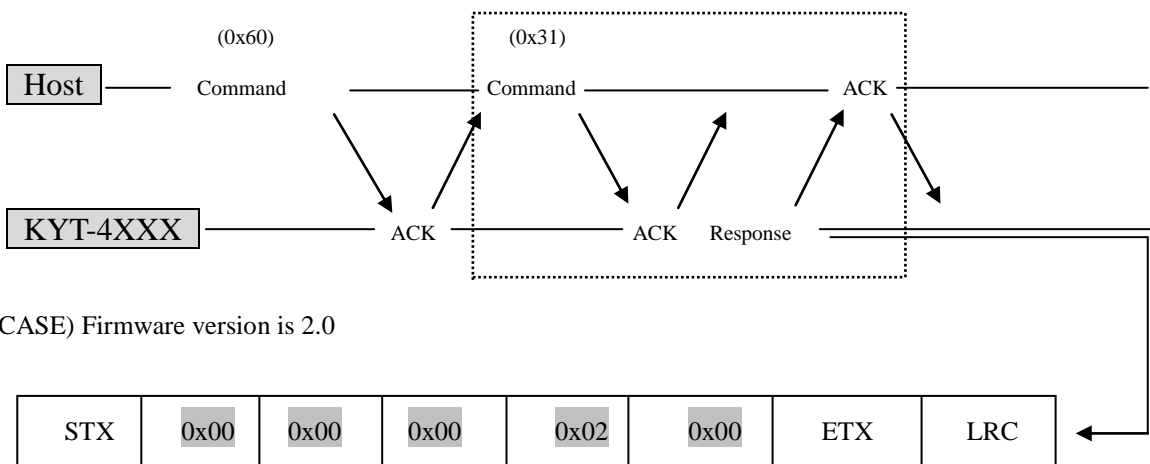

As Firmware version is not checked by sending Command (0x60), Get Status Request Command should be sent thereafter. Then, User gets Firmware Version.

Doc No	KYT-46XXSeries SPECIFICATION	REV	PAGE	DATE
		c	30 OF 32	2010. 12.31.

※ Response to Status Request(0x31) following Command (0x60) is Firmware Versions, and Response to the next Status Request is about Dispenser.

7.4. Response Timing

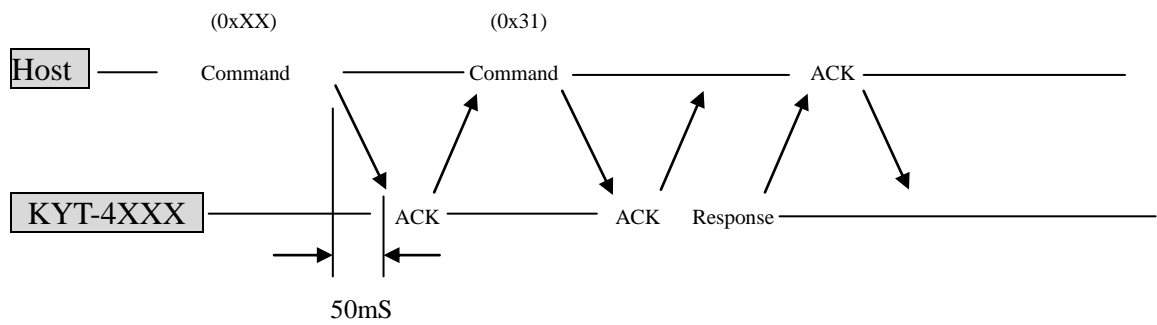

All of Command should be sent from Host to KYT-4XXX within 50ms time duration.

Doc No	KYT-46XXSeries SPECIFICATION	REV	PAGE	DATE
		c	31 OF 32	2010. 12.31.

8. Flow chart.

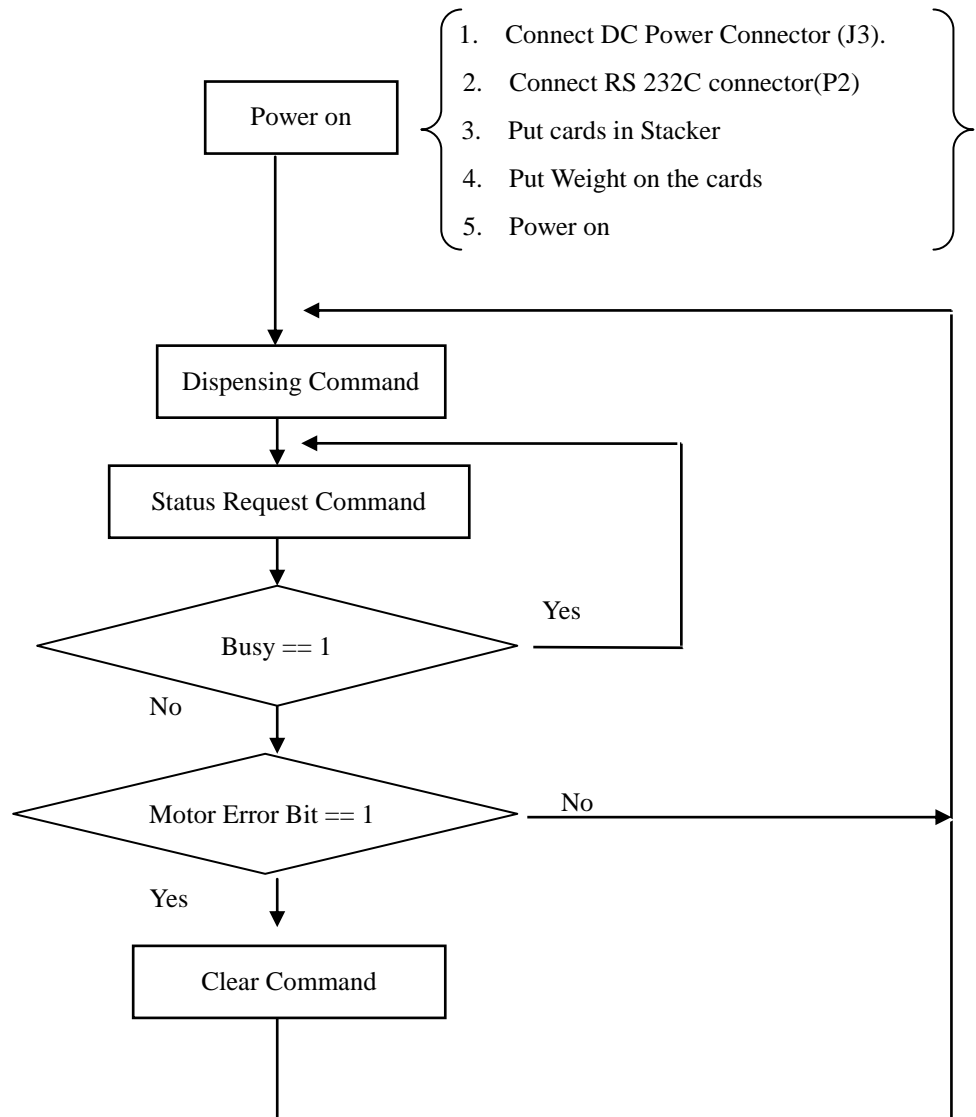

Doc No	KYT-46XXSeries SPECIFICATION	REV	PAGE	DATE
			c	32 OF 32

9. Technical Drawing.

9.1 KYT-46XXS

Doc No	KYT-46XXSeries SPECIFICATION	REV	PAGE	DATE
		C	33 OF 32	2010. 12.31.

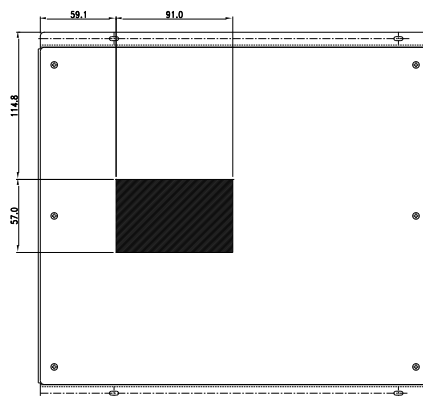
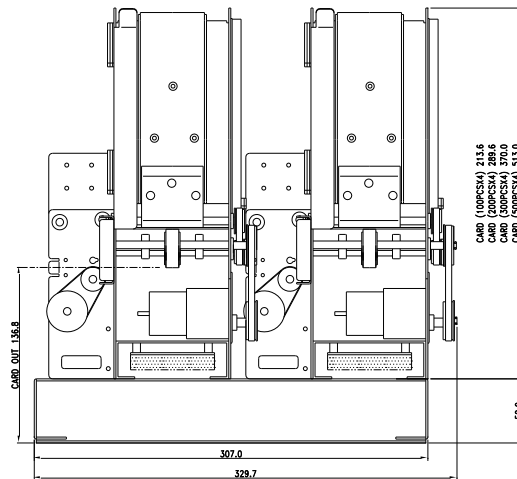
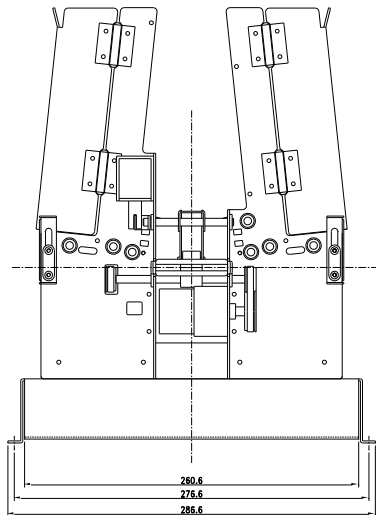
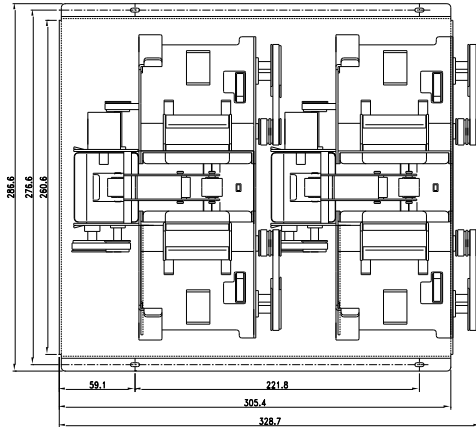

9.2 KYT-46XXC

Doc No	KYT-46XXSeries SPECIFICATION	REV	PAGE	DATE
		C	34 OF 32	2010. 12.31.

