



Ingeniería Electrónica
SMART IDENT

Specifications

User Manual

KYX-27000 Rev. D

Doc No	KYX27XXX SERIES	REV	PAGE	DATE
	SPECIFICATIONS	D	2 OF 31	2010. 05 . 13.

KYX-27XXX

Doc No	KYX27XXX SERIES SPECIFICATIONS	REV	PAGE	DATE
		D	3 OF 31	2010.05.13.

APPROVAL		

RESP. DEPT.	R & D		ORIGINATOR			
	DEPT.	Int'l Sales				
APPROVAL & CONFIRMATUON	APPROVAL BY					
	DEPT.				DOC. CON	APP.
	APPROVED BY					

• REVISION HISTORY

CHECK	DATE	DESCRIPTION	REV.	PAGE
1	2006.06.27		A	31
2	2006.11.2	Modified the model name information in the SPEC	B	31
3	2007.01.25	Typing error is Corrected	C	31
4	2010.05.13	Model number rule is modified	D	31

Doc No	KYX27XXX SERIES SPECIFICATIONS	REV	PAGE	DATE
		D	4 OF 31	2010. 05 . 13.

C O N T E N T S

1. Overview -----	5
2. Features -----	5
3. System Block Diagram -----	6
4. Environmental Requirements -----	7
5. Specifications -----	7
6. DC Power Connector -----	8
7. Technical Drawing -----	9
 Annex	
Rs232C Interface -----	10
TTL Interface -----	22
Sensor Name -----	31

Doc No	KYX27XXX SERIES SPECIFICATIONS	REV	PAGE	DATE
		D	5 OF 31	2010. 05 . 13.

MODEL NAME INFORMATION

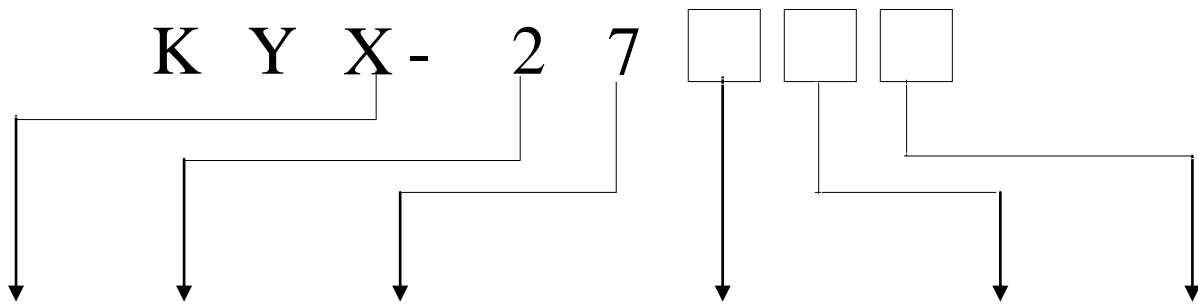

Interface	Function	Type	Option	Capacity	Thickness
T : RS232C L : TTL	2 : Dispenser	7: Wrapped/Unwrapped card dispenser	1: Double card detect & capture 2: Without double card detect & capture	2: 150 PCS 3: 300 PCS 4: 500 PCS	A: 0.2 T B: 0.38 T C: 0.5 T D: 0.76 T E: 0.84T F: 1.0 T

Doc No	KYX27XXX SERIES SPECIFICATIONS	REV	PAGE	DATE
		D	6 OF 31	2010. 05 . 13.

1. Overview

KYT-27XXX Main Control Board is designed to control the TTL interface board of KYL-27XXX Wrapped Card Dispenser upto 8 units at one Main Control Board.

2. Features

- 1) Single column wrapped card dispenser
- 2) Adjustable card thickness : 0.2mm to 1.00mm
- 3) Adjustable card dispensing width(card length) : upto 120mm
- 4) Wrapped card size : width : ISO standard , length max 120 mm
- 5) Capacity : up to 100 cards for 1.00 mm thickness cards
(30 mm higher than the first sample)
- 6) A Simple I/O interface (TTL interface type)
- 7) Double card detection system :
 - can be guaranteed for 0.4 mm to 1.00 mm thickness cards.
 - The detected thickness must be adjustable easily in the field directly from the end user(the owner of the complete card dispensing machine).
 - The calibration of screw shall be thin thread screw for better calibration
 - LED for calibration shall be two pcs.
- 8) Ejection function : a specific guide electronically controlled will divert the cards in a rejection box in case of double cards has been detected.
- 9) Card Empty Checking function
- 10) Frames of WCD shall be stainless steel material, not normal steel material.

Doc No	KYX27XXX SERIES SPECIFICATIONS	REV	PAGE	DATE
		D	7 OF 31	2010.05.13.

3. System Block Diagram

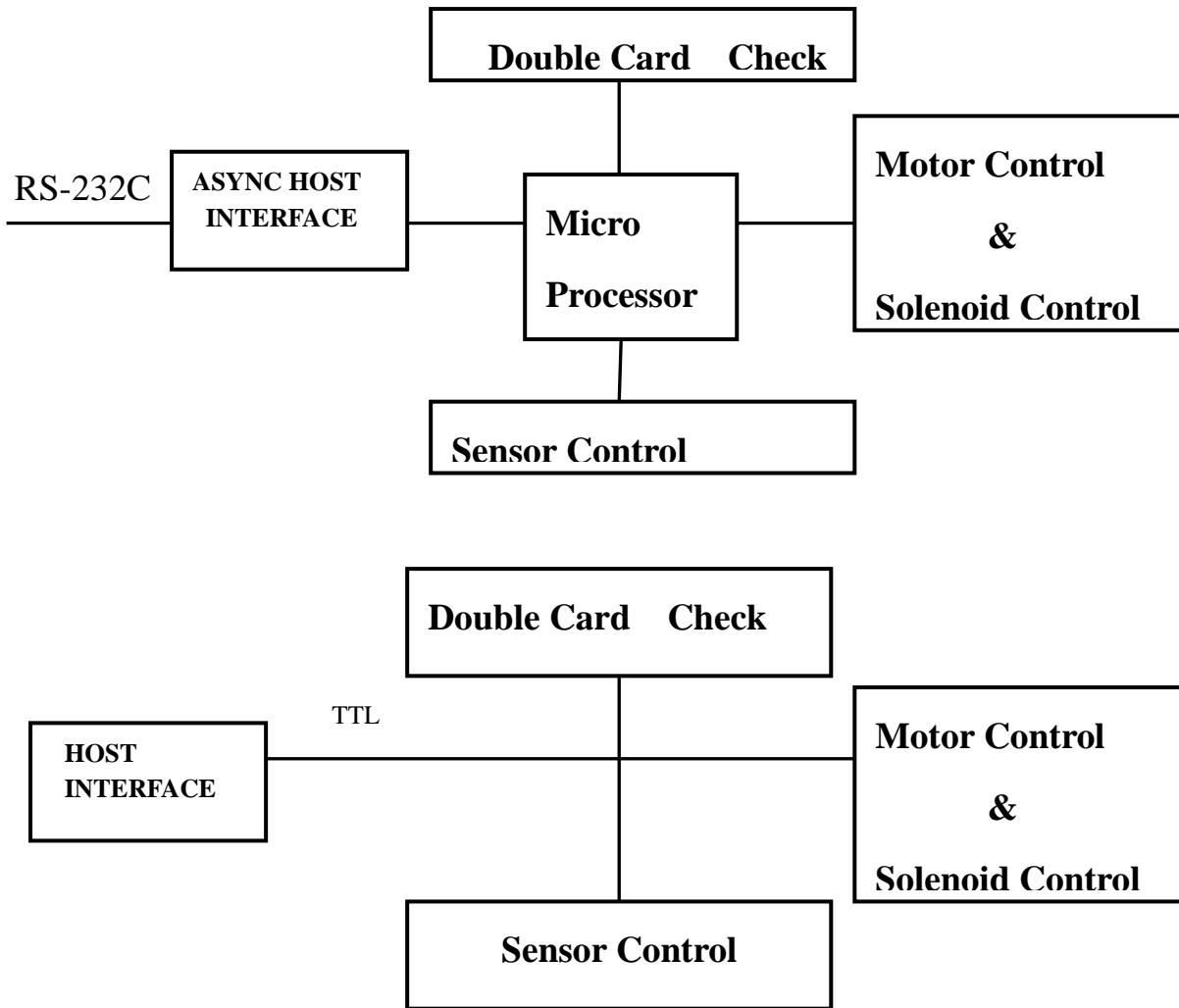

Doc No	KYX27XXX SERIES SPECIFICATIONS	REV	PAGE	DATE
		D	8 OF 31	2010. 05 . 13.

4. Environmental Requirements

4.1 Operating Temperature and Humidity : 5~40°C, 0~90% RH

4.2 Conservation Temperature and Humidity : -20~70°C, 0~95% RH

5. Specifications

5.1. Power Consumption

5.1.1 Motor Driver : Output Current 1.5A Per Channel.

5.1.2 Solenoid Driver : Output Current 0.8A Per Channel.

5.1.3 Input voltage : DC 24V Only (DC $\pm 5\%$, 3A) .

5.1.4 Stand By : 110 mA(+5%).

Doc No	KYX27XXX SERIES SPECIFICATIONS	REV	PAGE	DATE
		D	9 OF 31	2010. 05 . 13.

6. DC Power Connector.

6.1. DC Power Connector

* **Interface connector – RS232C.**

- **Part Number : 5557-04A, Manufacture : MOLEX**

. **Connector number : CN1**

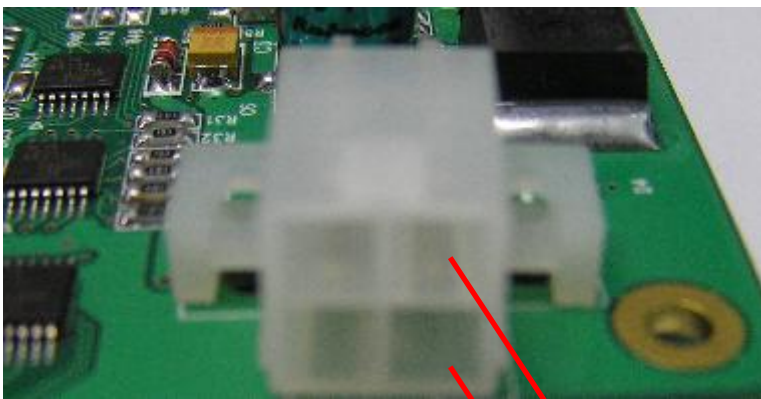

Pin 3. +24VDC

Pin 1. GND

Pin NO	Signal Name	Cable color	Direction
1	GND	Black	Input
2	Not use		
3	+24VDC	Yellow	
4	Not use		

. **Supply Voltage & Current Consumption**

With Load : DC 24V (±5%)– 3A

Doc No	KYX27XXX SERIES SPECIFICATIONS	REV	PAGE	DATE
		D	10 OF 31	2010. 05 . 13.

7. Technical Drawing

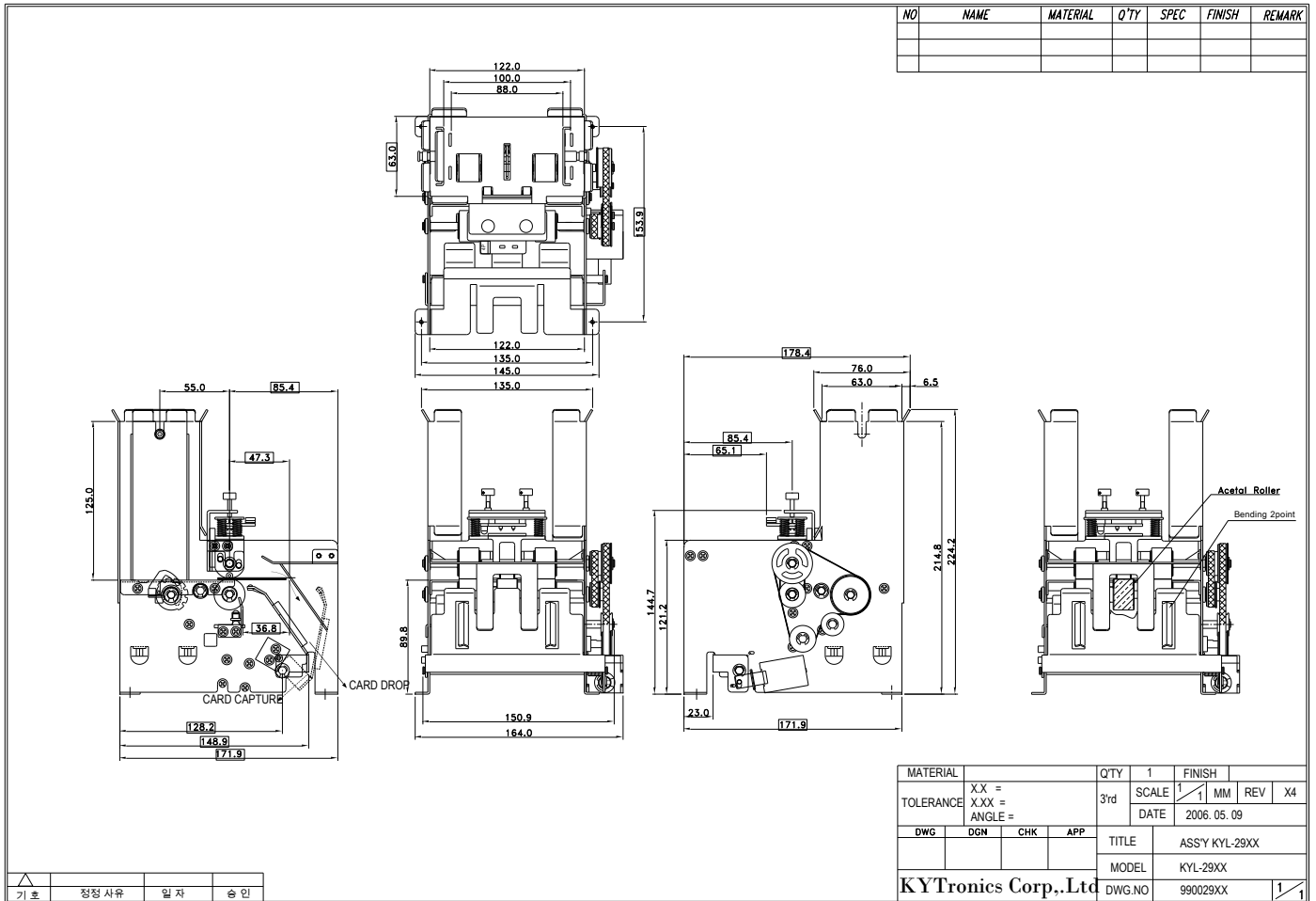

Doc No	KYX27XXX SERIES SPECIFICATIONS	REV	PAGE	DATE
			D	11 OF 31

Interface

Wrapped Card Dispenser.

MODEL: KYT- 27XXX

Doc No	KYX27XXX SERIES SPECIFICATIONS	REV	PAGE	DATE
		D	12 OF 31	2010. 05 . 13.

1. Interface Requirements.

1.1 Standard.

1.1.1 RS-232C Interface.

Part Number: D-SUB Standard 9Pin

Part Number : 5504F1-09S-02A-01-F1

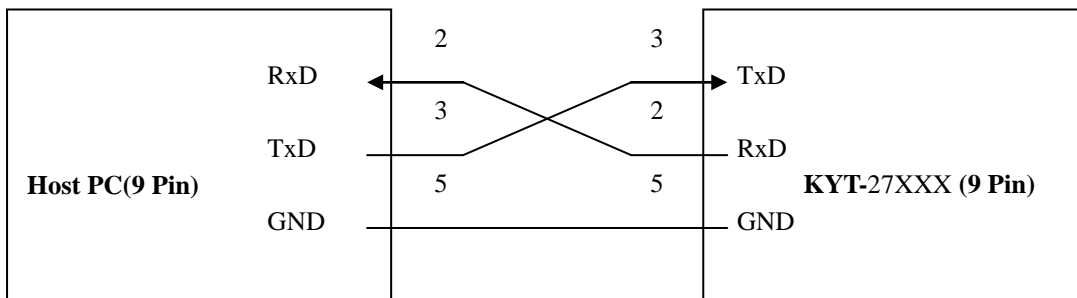

- Transmission Distance : Max. 1.5m

1.1.2 Pin Assignment.

- Connector Location Number : P1 - Part Number : 5504F1-09S-02A-01-F1

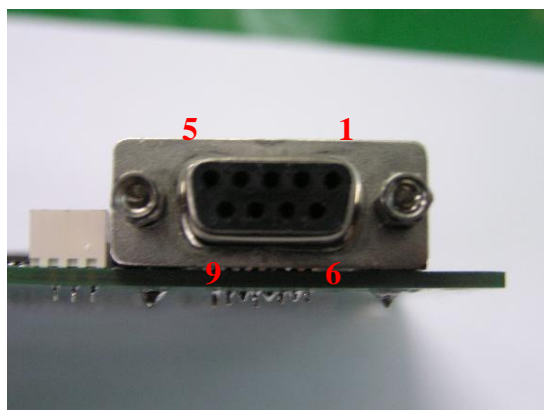

PIN N0	NAME
2	RXD
3	TXD
5	GND

Doc No	KYX27XXX SERIES SPECIFICATIONS	REV	PAGE	DATE
		D	13 OF 31	2010. 05 . 13.

1.2 Option.

1.2.1 RS-232C Interface.

Part Number: D-SUB Standard - 9Pin

Part Number : 53014-0310 (Molex)

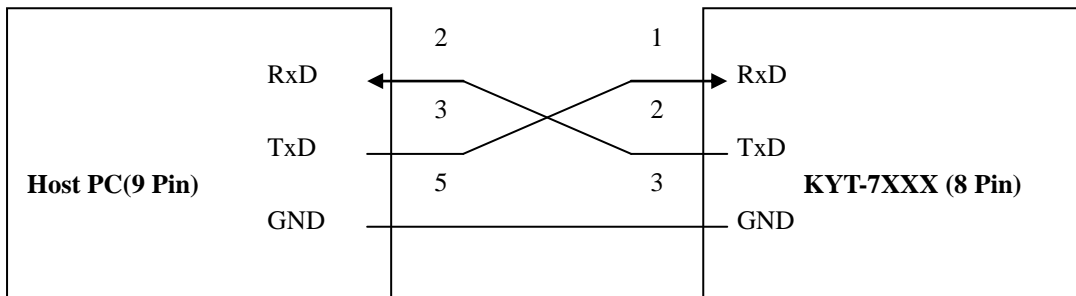

1.2.2 Pin Assignment.

* Connector Location Number : CN2 - Part Number : 53014-0310 (Molex)

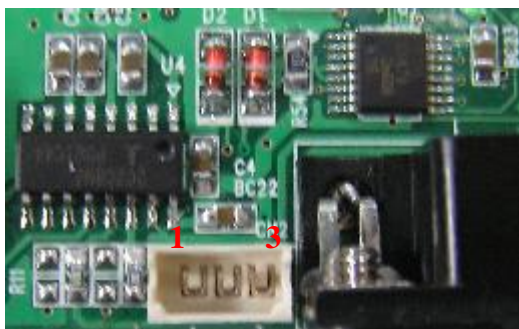

PIN NO	NAME
1	RxD
2	TxD
3	GND

2.Communication Method.

- 2.1. Asynchronous, Half duplex.
- 2.2. Baud Rate: 9600, 19200 38400 (Default: 19200 BPS)
- 2.3. Start Bit: 1Bit
- 2.4. Data Length: 8Bits
- 2.5. Parity: None
- 2.6. Stop Bit: 1Bit

Doc No	KYX27XXX SERIES SPECIFICATIONS	REV	PAGE	DATE
		D	14 OF 31	2010. 05 . 13.

3. Control Characters.

NANE	Hex Value	Description
SOH	01	Start of Header
STX	02	Start of Text
ETX	03	End of Text
EOT	04	End of Transmission
ENQ	05	Enquiry
ACK	06	Positive Acknowledge
NAK	15	Negative Acknowledge
CAN	18	Cancel

4. Frame Format.

4.1. Command structure

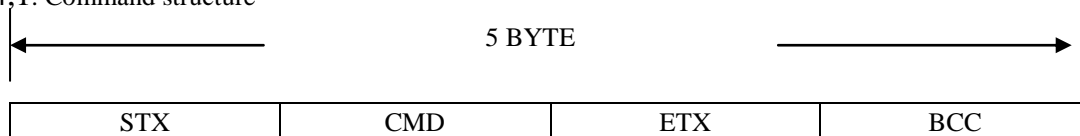

LRC : Longitudinal Redundancy Check– Calculated by EX-ORing all Characters from STX to ETX inclusive

4.2. Response structure

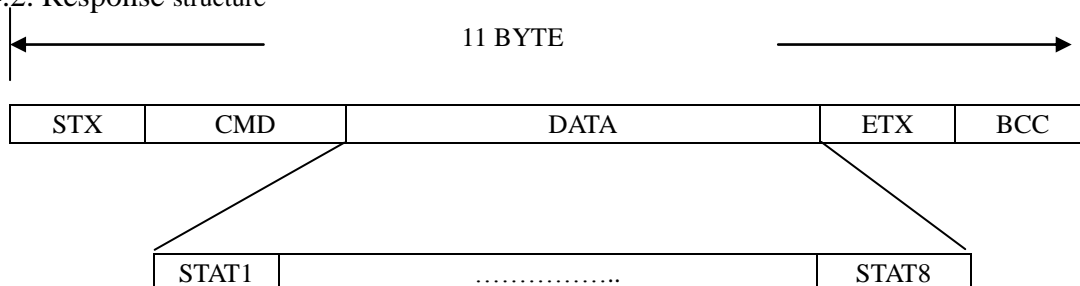

Doc No	KYX27XXX SERIES SPECIFICATIONS	REV	PAGE	DATE
		D	15 OF 31	2010. 05 . 13.

4.3. STAT Structure Format.

4.3.1 STAT1

BIT 7	BIT 6	BIT 5	BIT 4	BIT 3	BIT 2	BIT 1	BIT 0
-------	-------	-------	-------	-------	-------	-------	-------

BIT	Description		REMARK
	1	0	
7	Always	X	
6	Busy	Ready	Check Dispenser Status
5	Dispense Solenoid Error	Dispense Solenoid Good	Check Solenoid actuation
4	Finish Sensor Detection.	Finish Sensor Non-Detection	Check Card Position
3	Dispense Motor Jam	Dispense Motor Good..	Check Motor Jamming
2	Double Card Detection.	Double Card Non-Detection.	Check Double Card
1	Dispense Empty	.Dispense Good.	Check the card presence in stacker
0	Dispenser Detection.	Dispenser Non-Detection.	Check if Dispenser is connected to the Main board

4.3.2 STAT2

BIT 7	BIT 6	BIT 5	BIT 4	BIT 3	BIT 2	BIT 1	BIT 0
-------	-------	-------	-------	-------	-------	-------	-------

BIT	Description		REMARK
	1	0	
7	Always	X	
6	X	X	
5	Dispense Solenoid Error	Dispense Solenoid Good	Check Solenoid actuation
4	Finish Sensor Detection.	Finish Sensor Non-Detection	Check Card Position
3	Dispense Motor Jam	Dispense Motor Good..	Check Motor Jamming
2	Double Card Detection.	Double Card Non-Detection.	Check Double Card
1	Dispense Empty	.Dispense Good.	Check the card presence in stacker
0	Dispense Detection.	Dispense Non-Detection.	Check if Dispenser is connected to the Main board

Doc No	KYX27XXX SERIES SPECIFICATIONS	REV	PAGE	DATE
		D	16 OF 31	2010. 05 . 13.

4.3.3 STAT3

BIT 7	BIT 6	BIT 5	BIT 4	BIT 3	BIT 2	BIT 1	BIT 0
-------	-------	-------	-------	-------	-------	-------	-------

BIT	Description		REMARK
	1	0	
7	Always	X	
6	X	X	
5	Dispense Solenoid Error	Dispense Solenoid Good	Check Solenoid actuation
4	Finish Sensor Detection.	Finish Sensor Non-Detection	Check Card Position
3	Dispense Motor Jam	Dispense Motor Good..	Check Motor Jamming
2	Double Card Detection.	Double Card Non-Detection.	Check Double Card
1	Dispense Empty	.Dispense Good.	Check the card presence in stacker
0	Dispense Detection.	Dispense Non-Detection.	Check if Dispenser is connected to the Main board

4.3.4 STAT4

BIT 7	BIT 6	BIT 5	BIT 4	BIT 3	BIT 2	BIT 1	BIT 0
-------	-------	-------	-------	-------	-------	-------	-------

BIT	Description		REMARK
	1	0	
7	Always	X	
6	X	X	
5	Dispense Solenoid Error	Dispense Solenoid Good	Check Solenoid actuation
4	Finish Sensor Detection.	Finish Sensor Non-Detection	Check Card Position
3	Dispense Motor Jam	Dispense Motor Good..	Check Motor Jamming
2	Double Card Detection.	Double Card Non-Detection.	Check Double Card
1	Dispense Empty	.Dispense Good.	Check the card presence in stacker
0	Dispense Detection.	Dispense Non-Detection.	Check if Dispenser is connected to the Main board

Doc No	KYX27XXX SERIES SPECIFICATIONS	REV	PAGE	DATE
		D	17 OF 31	2010. 05 . 13.

4.3.5 STAT5

BIT 7	BIT 6	BIT 5	BIT 4	BIT 3	BIT 2	BIT 1	BIT 0
-------	-------	-------	-------	-------	-------	-------	-------

BIT	Description		REMARK
	1	0	
7	Always	X	
6	X	X	
5	Dispense Solenoid Error	Dispense Solenoid Good	Check Solenoid actuation
4	Finish Sensor Detection.	Finish Sensor Non-Detection	Check Card Position
3	Dispense Motor Jam	Dispense Motor Good..	Check Motor Jamming
2	Double Card Detection.	Double Card Non-Detection.	Check Double Card
1	Dispense Empty	.Dispense Good.	Check the card presence in stacker
0	Dispense Detection.	Dispense Non-Detection.	Check if Dispenser is connected to the Main board

4.3.6 STAT6

BIT 7	BIT 6	BIT 5	BIT 4	BIT 3	BIT 2	BIT 1	BIT 0
-------	-------	-------	-------	-------	-------	-------	-------

BIT	Description		REMARK
	1	0	
7	Always	X	
6	X	X	
5	Dispense Solenoid Error	Dispense Solenoid Good	Check Solenoid actuation
4	Finish Sensor Detection.	Finish Sensor Non-Detection	Check Card Position
3	Dispense Motor Jam	Dispense Motor Good..	Check Motor Jamming
2	Double Card Detection.	Double Card Non-Detection.	Check Double Card
1	Dispense Empty	.Dispense Good.	Check the card presence in stacker
0	Dispense Detection.	Dispense Non-Detection.	Check if Dispenser is connected to the Main board

Doc No	KYX27XXX SERIES SPECIFICATIONS	REV	PAGE	DATE
		D	18 OF 31	2010. 05 . 13.

4.3.7 STAT7

BIT 7	BIT 6	BIT 5	BIT 4	BIT 3	BIT 2	BIT 1	BIT 0
-------	-------	-------	-------	-------	-------	-------	-------

BIT	Description		REMARK
	1	0	
7	Always	X	
6	X	X	
5	Dispense Solenoid Error	Dispense Solenoid Good	Check Solenoid actuation
4	Finish Sensor Detection.	Finish Sensor Non-Detection	Check Card Position
3	Dispense Motor Jam	Dispense Motor Good..	Check Motor Jamming
2	Double Card Detection.	Double Card Non-Detection.	Check Double Card
1	Dispense Empty	.Dispense Good.	Check the card presence in stacker
0	Dispense Detection.	Dispense Non-Detection.	Check if Dispenser is connected to the Main board

4.3.7 STAT8

BIT 7	BIT 6	BIT 5	BIT 4	BIT 3	BIT 2	BIT 1	BIT 0
-------	-------	-------	-------	-------	-------	-------	-------

BIT	Description		REMARK
	1	0	
7	Always	X	
6	X	X	
5	Dispense Solenoid Error	Dispense Solenoid Good	Check Solenoid actuation
4	Finish Sensor Detection.	Finish Sensor Non-Detection	Check Card Position
3	Dispense Motor Jam	Dispense Motor Good..	Check Motor Jamming
2	Double Card Detection.	Double Card Non-Detection.	Check Double Card
1	Dispense Empty	.Dispense Good.	Check the card presence in stacker
0	Dispense Detection.	Dispense Non-Detection.	Check if Dispenser is connected to the Main board

Doc No	KYX27XXX SERIES SPECIFICATIONS	REV	PAGE	DATE
		D	19 OF 31	2010. 05 . 13.

5. Communication Protocol Sequence.

5.1. Status Request Function

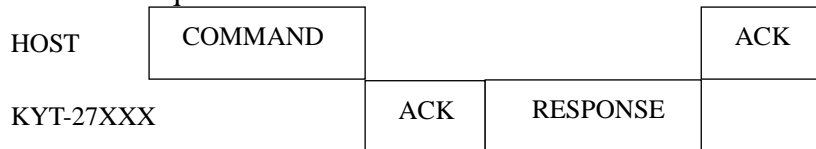

5.2. Status Request Function Ω Command.

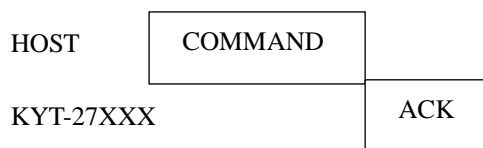

5.3 Other Sequence.

5.3.1. Case 1

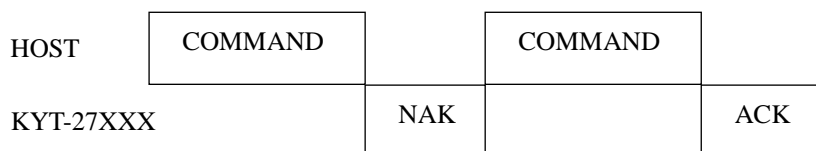

5.3.2. Case2 : If no Response is returned within 50ms after sending command, send the Command again.

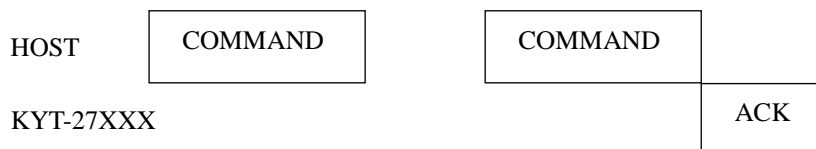

5.3.3. Case3 : If Response is "CAN" after sending command, send the Command again.

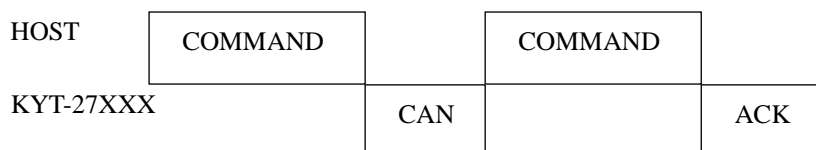

5.3.4. Case4 : If "ACK" is responded for Baud Rate change, send the Command again after 50ms.



Doc No	KYX27XXX SERIES SPECIFICATIONS	REV	PAGE	DATE
		D	20 OF 31	2010. 05 . 13.

5.3.5. Case5 : Rom Version check (refer to Page 17)

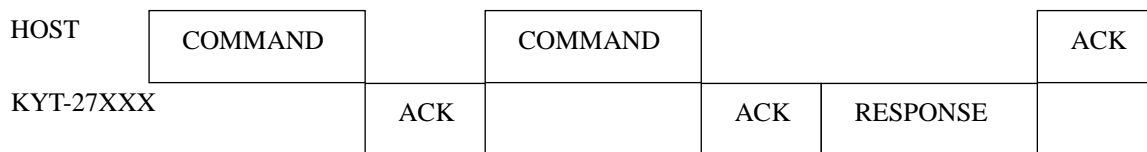

5.3.6. Case6 : If “NAK” is returned after sending Response, send Response again.

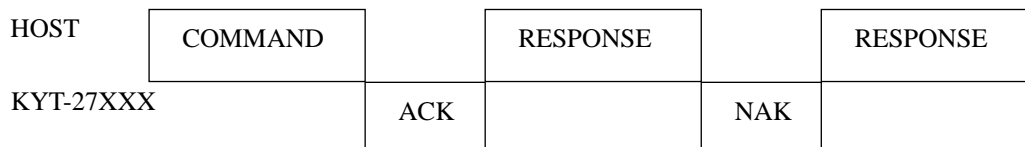

After sending Response, if next Command is received before receiving “ACK, execute the next command.
If “NAK” is returned after sending Response, send Response again.

6. RS-232C Control Command

NO	HEX VALUE(2Byte)	FUNCTION
1	0x30,0x30	“Clear”
2	0x30,0x31	“Status Request” : Module Status Check.
3	0x30,0x32	“F/W Rom Version” : Rom Version Check.
4	0x40,0x31	“Card Issue #1”
	0x40,0x32	“Card Issue #2”
	0x40,0x33	“Card Issue #3”
	0x40,0x34	“Card Issue #4”
	0x40,0x35	“Card Issue #5”
	0x40,0x36	“Card Issue #6”
	0x40,0x37	“Card Issue #7”
	0x40,0x38	“Card Issue #8”
5	0x50,0x30	“Baud Rate Change” : 19200BPS . (default)
	0x50,0x31	“Baud Rate Change” : 384000BPS.

6.1. Clear : When Card Jam or Solenoid Error happen, clear Status bit.

● Command Format

STX	COMMAND(2BYTE) – 0x30 0x30	ETX	BCC
-----	----------------------------	-----	-----

: If Status of specific Dispenser is Motor Jam or Solenoid Error, card dispense command can not be executed.
So the Error status should be released by “Clear” command before sending dispense command.

6.2. Status Request : Check each Module status

● Command Format

STX	COMMAND(2BYTE) – 0x30 0x31	ETX	BCC
-----	----------------------------	-----	-----

● Response Format

STX	STAT(8BYTE)	ETX	BCC
-----	-------------	-----	-----

For STAT Format, please see Page 11- 3.3. STAT Structure Format.

Doc No	KYX27XXX SERIES SPECIFICATIONS	REV	PAGE	DATE
		D	21 OF 31	2010. 05 . 13.

6.3. F/W Rom Version.

● Command Format

STX	COMMAND(2BYTE) – 0x30 0x32	ETX	BCC
-----	----------------------------	-----	-----

: After send this Command, if send Status Request Command, Response(STAT) will be F/W Rom Version

In the Response, only ST1,ST2,ST3 is displayed and other part(ST4~ST8) will be “0x30”

Ex) If the ROM version is 1.01, Response is ST1(0x31), ST2(0x30),ST3(0x31) and other part(ST4~ST8) will be “ 0x30”

6.4. Issue : Dispense the card in the stacker

● Command Format

STX	COMMAND(2BYTE) – 0x40 (0x31~0x38)	ETX	BCC
-----	-----------------------------------	-----	-----

6.5. Baud Rate Change

● Command Format

STX	COMMAND(2BYTE) – 0x50 (0x30~0x31)	ETX	BCC
-----	-----------------------------------	-----	-----

: If “ACK” is responded for Baud Rate change, send the Command again after 50ms.

Command	Baud Rate
0x40, 0x30	19200BPS (default)
0x40, 0x31	384000BPS

● **RS232C MAIN B/D.**

CON1 : Card Issue #1 CON2 : Card Issue #2 CON3 : Card Issue #3 CON4 : Card Issue #4

CON5 : Card Issue #5 CON6 : Card Issue #6 CON7 : Card Issue #7 CON8 : Card Issue #8

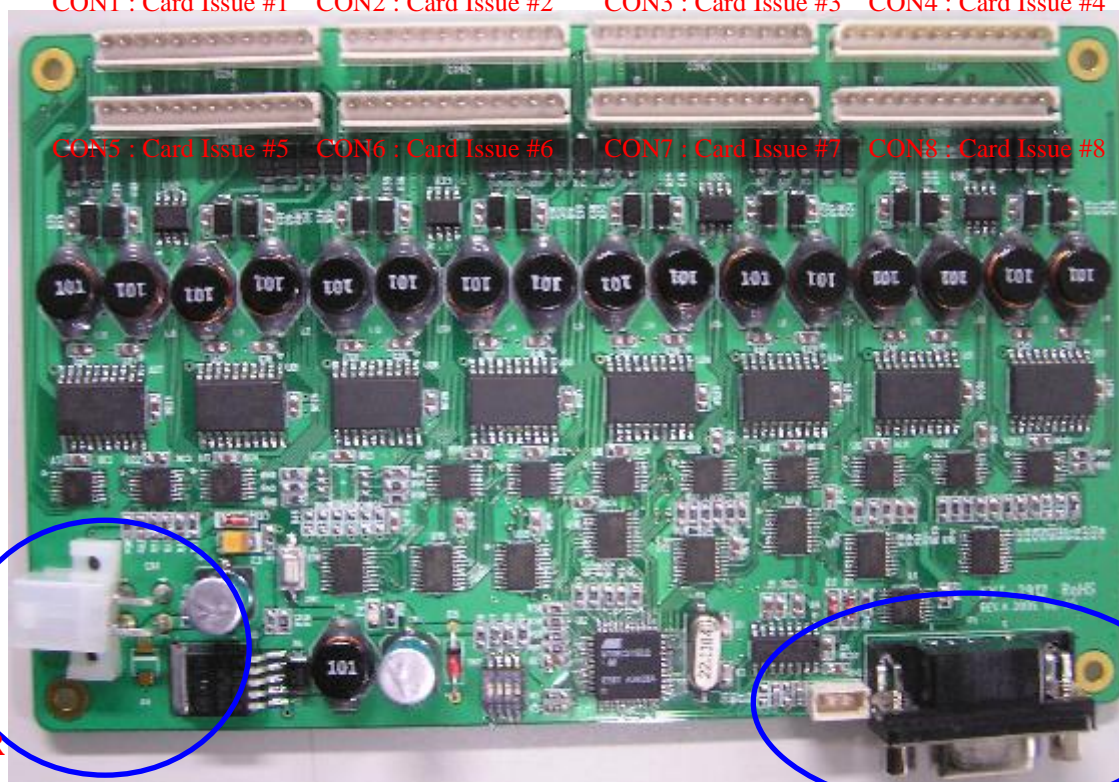

POWER

RS-232C

Doc No	KYX27XXX SERIES SPECIFICATIONS	REV	PAGE	DATE
		D	22 OF 31	2010. 05 . 13.

* Main B/D Pin Name(CON1 ~ CON8).

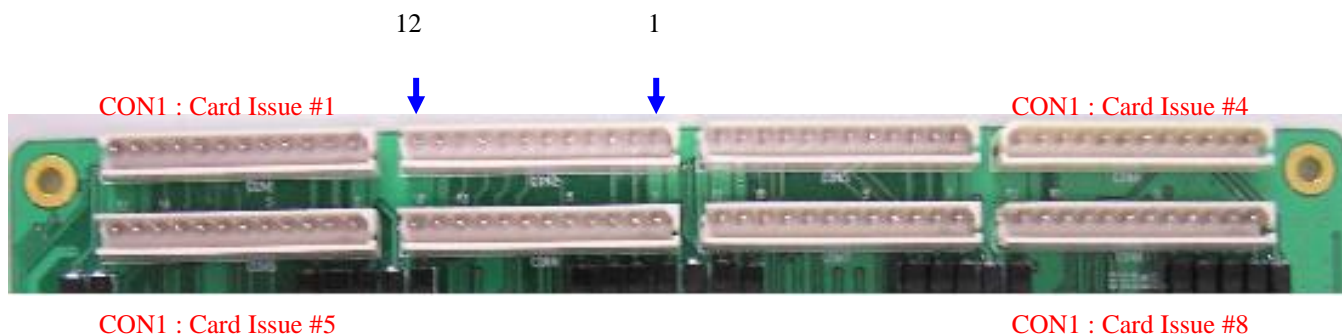

No	Signal Name	Input/Output	Configuration
1	DC 24V	INPUT	
2	MOTOR-A	INPUT	
3	MOTOR-B	INPUT	
4	SOLENOID	OUTPUT	
5	SENSOR_EMPTY	OUTPUT	Check card presence on the stacker
6	SENSOR_FINISH	OUTPUT	Check card location
7	SENSOR_SHTTUR	OUTPUT	Check Solenoid actuation
8	SENSOR_DOUBLE_A	OUTPUT	Check Double Card dispensing
9	SENSOR_DOUBLE_B	OUTPUT	
10	GND		
11	DC 5V	INPUT	
12	GND		

Doc No	KYX27XXX SERIES SPECIFICATIONS	REV	PAGE	DATE
			D	23 OF 31

Interface

Wrapped Card Dispenser.

MODEL: KYL- 27XXX

Doc No	KYX27XXX SERIES SPECIFICATIONS	REV	PAGE	DATE
		D	24 OF 31	2010. 05 . 13.

1. TTL Interface

1.1. Pin Definition Table.

. Part Number : 99-99-0996 (MOLEX), Connector(CON1)

. Connect Pin Table(Male)

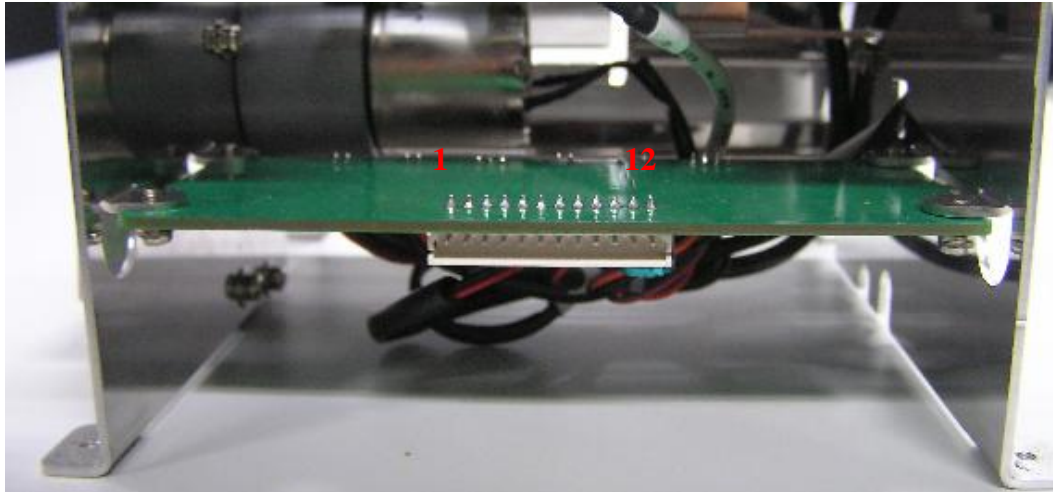

No	Signal Name	Input/Output	Configuration
1	DC 24V	INPUT	
2	MOTOR-A	INPUT	
3	MOTOR-B	INPUT	
4	SOLENOID	OUTPUT	
5	SENSOR_EMPTY	OUTPUT	Check card presence on the stacker
6	SENSOR_FINISH	OUTPUT	Check card location
7	SENSOR_SHTTUR	OUTPUT	Check Solenoid actuation
8	SENSOR_DOUBLE_A	OUTPUT	Check Double Card diepensing
9	SENSOR_DOUBLE_B	OUTPUT	
10	GND		
11	DC 5V	INPUT	
12	GND		

Doc No	KYX27XXX SERIES SPECIFICATIONS	REV	PAGE	DATE
		D	25 OF 31	2010.05.13.

1.2 TTL MAIN B/D

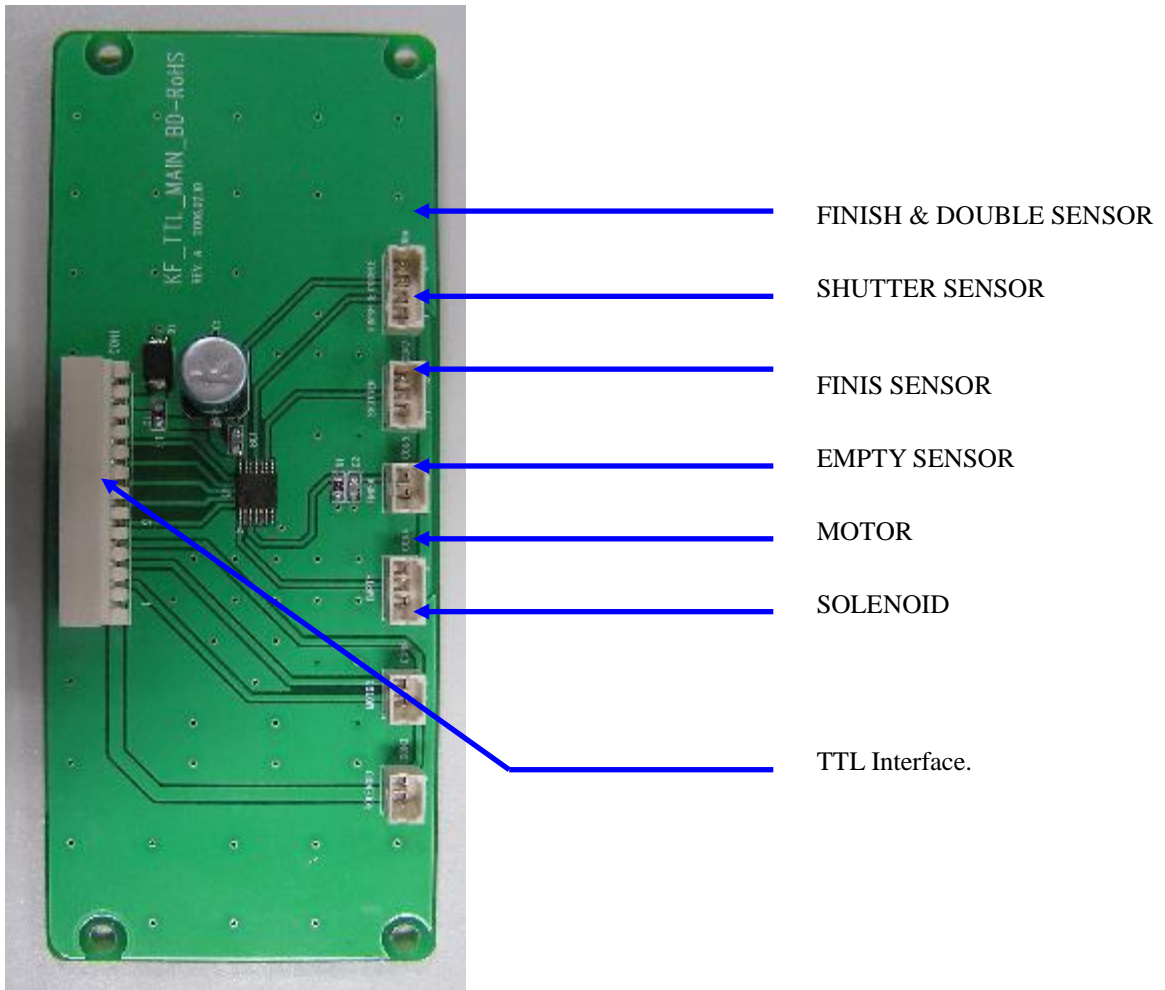

1.3 INPUT/OUTPUT SIGNAL

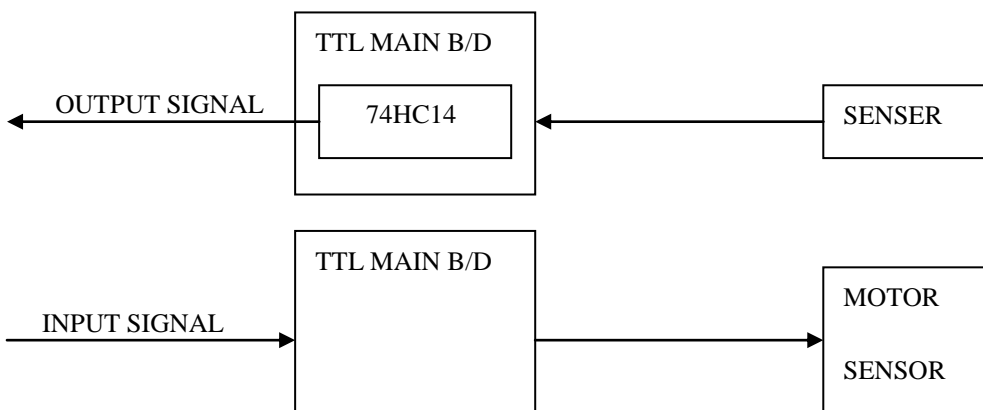

Doc No	KYX27XXX SERIES SPECIFICATIONS	REV	PAGE	DATE
		D	26 OF 31	2010. 05 . 13.

2. TTL Sequence

* Normal

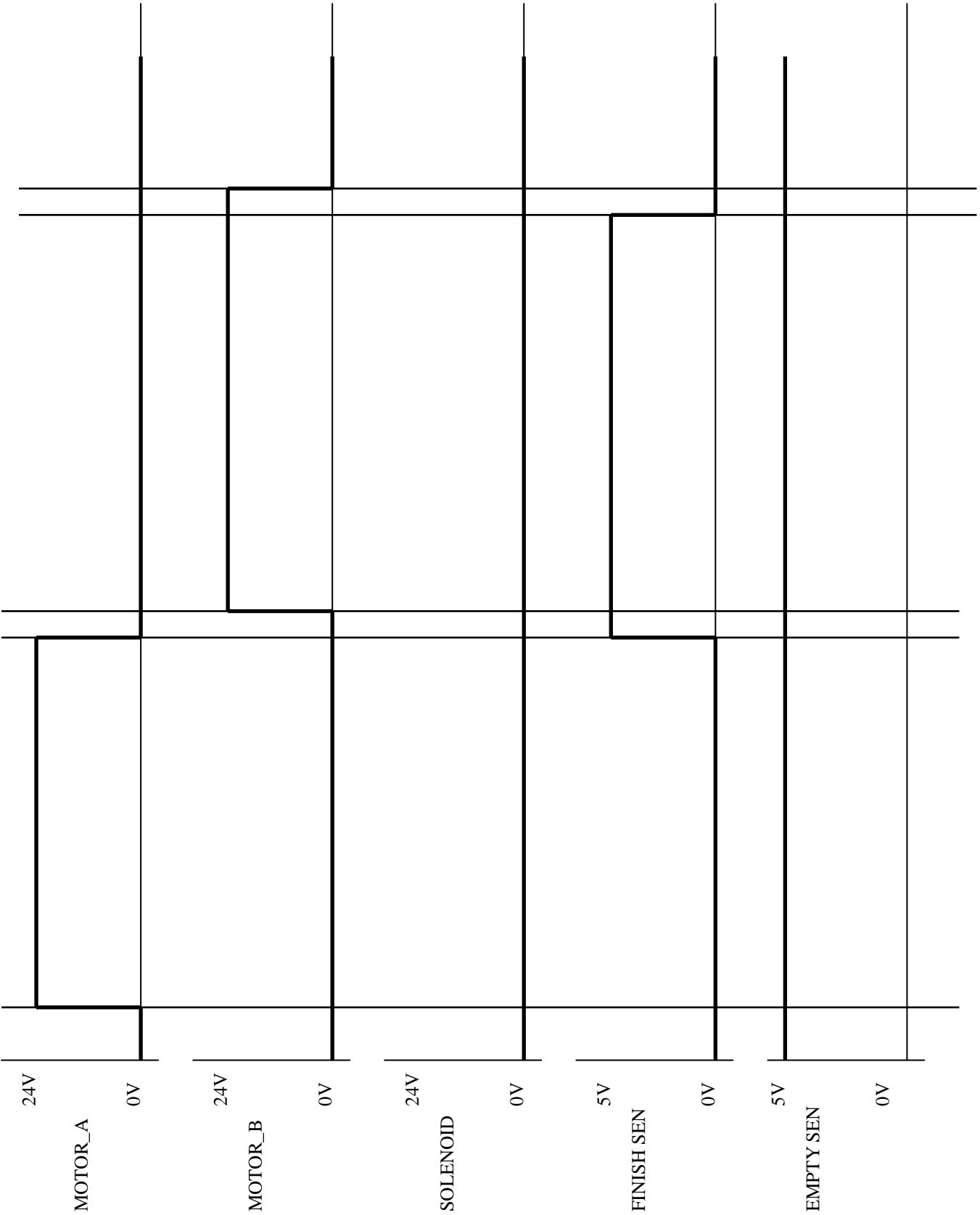

Doc No	KYX27XXX SERIES SPECIFICATIONS	REV	PAGE	DATE
		D	27 OF 31	2010. 05 . 13.

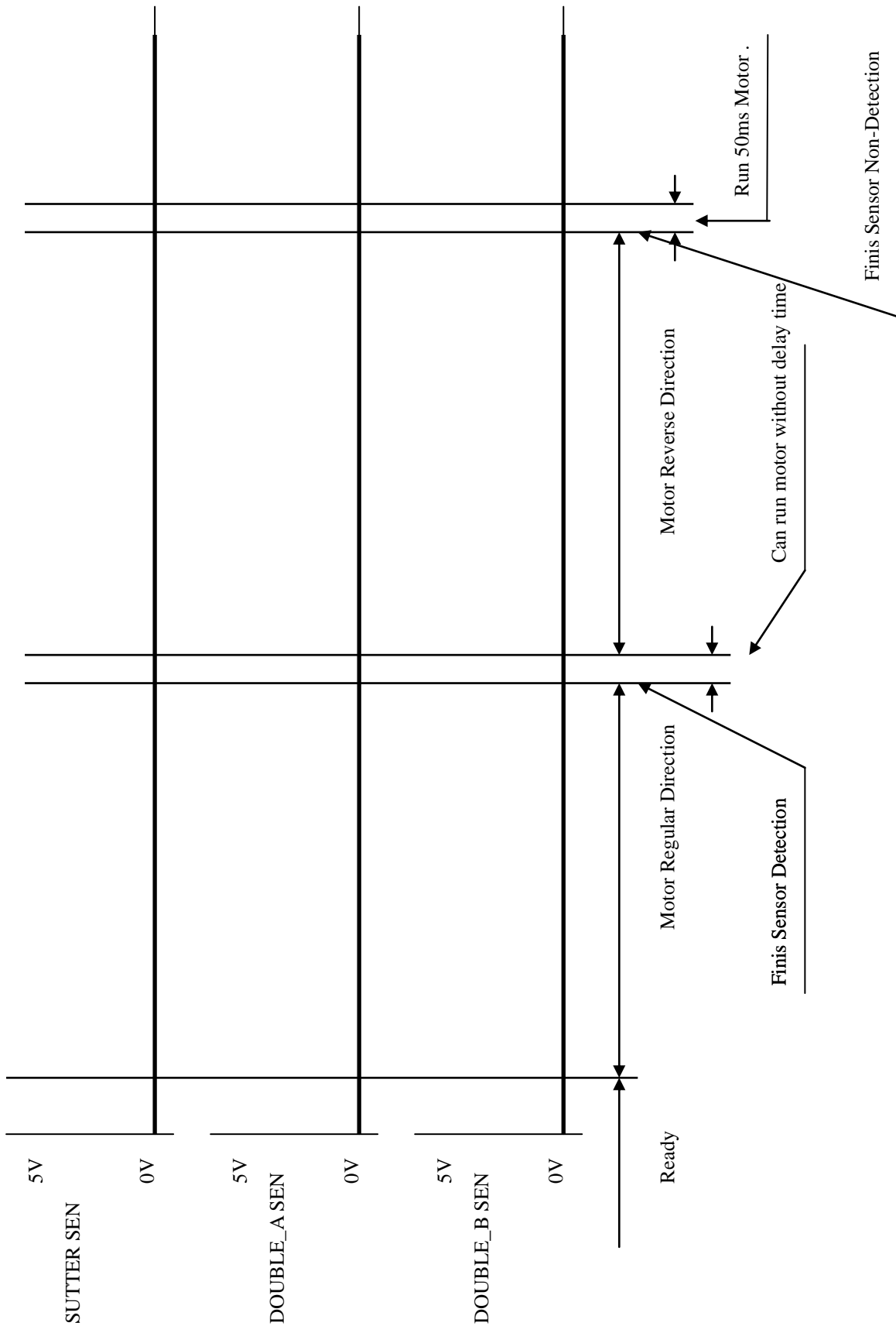

Doc No	KYX27XXX SERIES SPECIFICATIONS	REV	PAGE	DATE
		D	28 OF 31	2010. 05 . 13.

* Double Card Detection

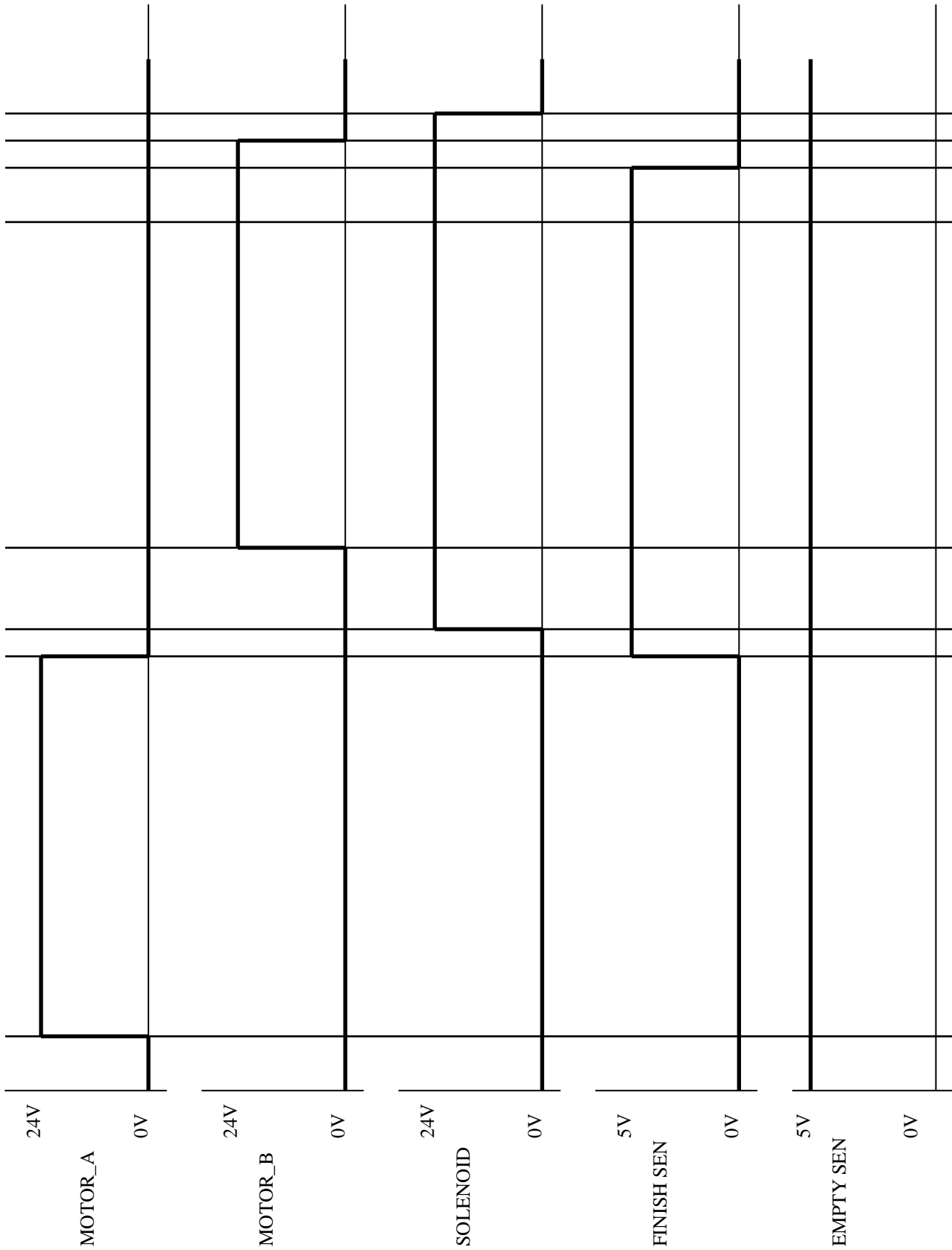

Doc No	KYX27XXX SERIES SPECIFICATIONS	REV	PAGE	DATE
		D	29 OF 31	2010.05.13.

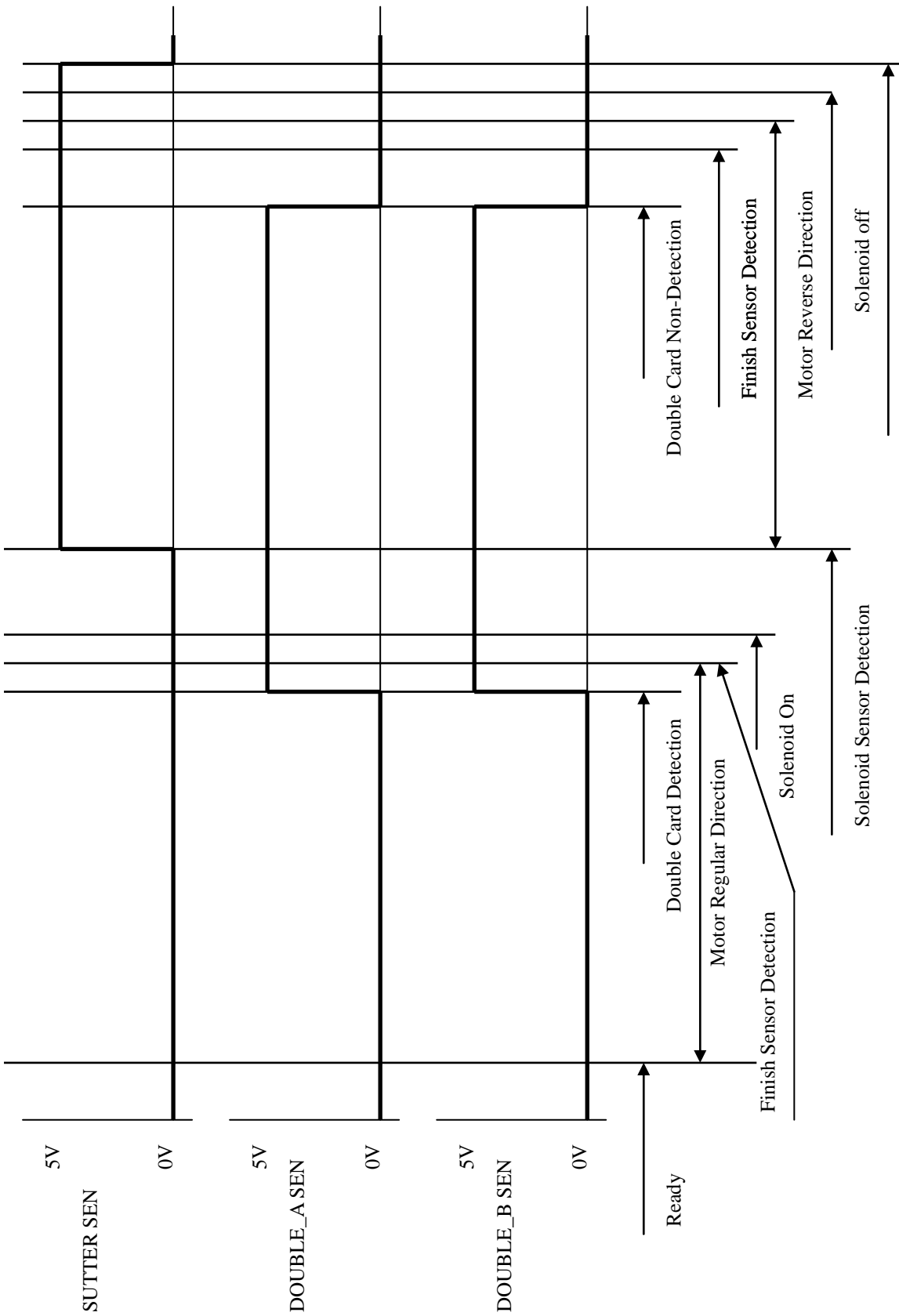

Doc No	KYX27XXX SERIES SPECIFICATIONS	REV	PAGE	DATE
		D	30 OF 31	2010. 05 . 13.

Example 1) TTL Control Example

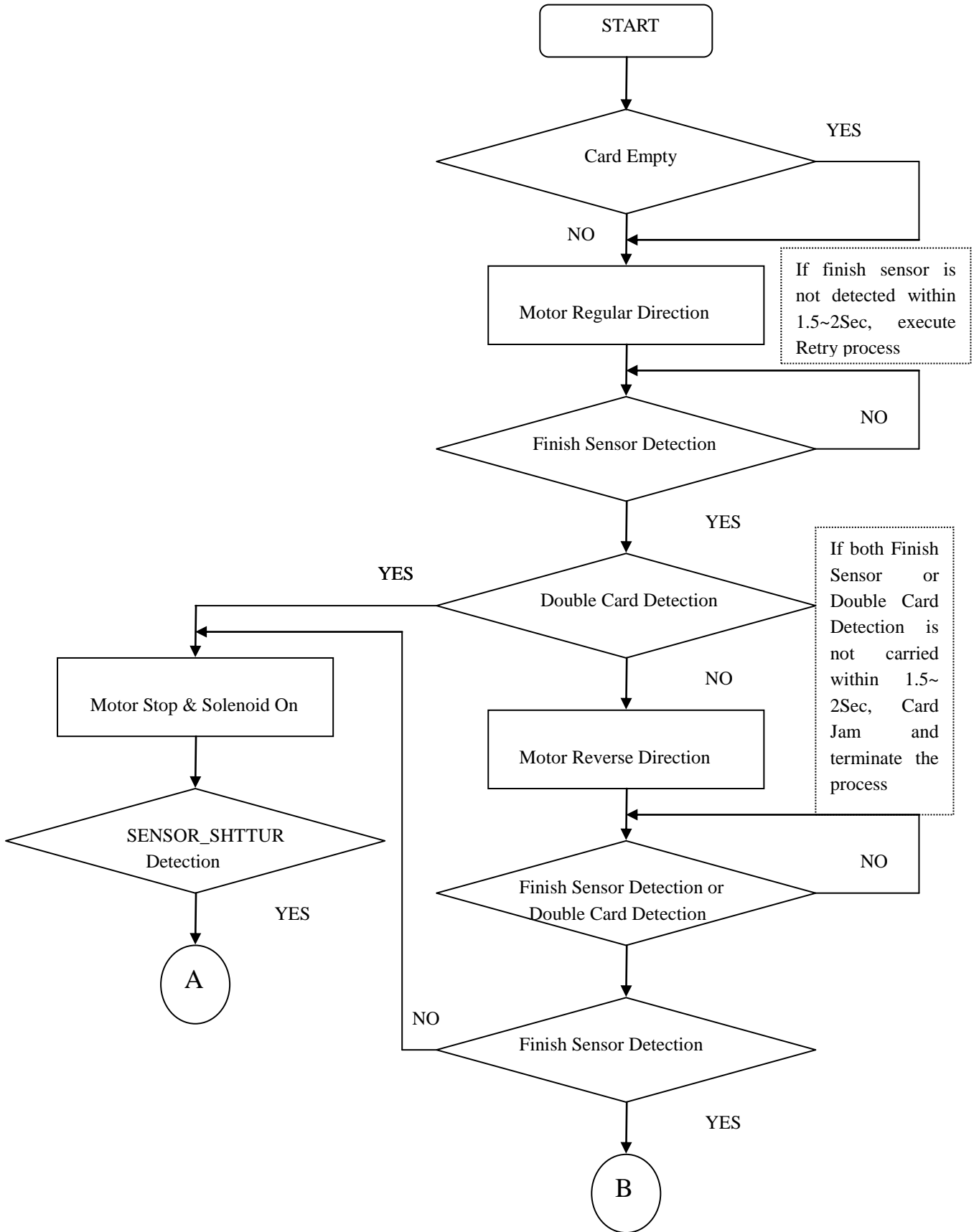

Doc No	KYX27XXX SERIES SPECIFICATIONS	REV	PAGE	DATE
		D	31 OF 31	2010. 05 . 13.

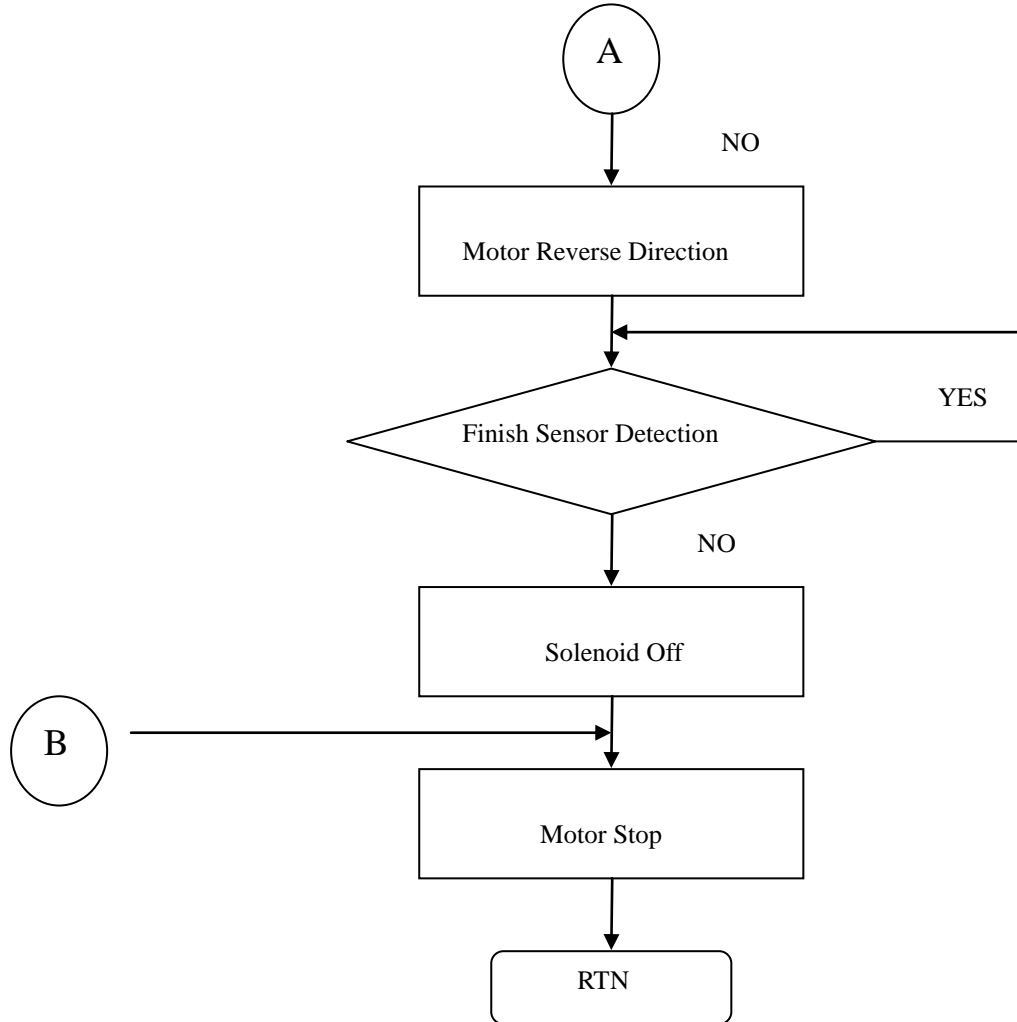

Doc No	KYX27XXX SERIES SPECIFICATIONS	REV	PAGE	DATE
		D	32 OF 31	2010.05.13.

<Sensor Name>

