



Ingeniería Electrónica  
*SMART IDENT*

---

# CARD DISPENSER MACHINE

## Specifications

---

User Manual

KYT-2300 Rev. F

<b>Doc No</b>	<b>KYX2300 SPECIFICATION</b>	<b>REV</b>	<b>PAGE</b>	<b>DATE</b>
		F	2 OF 15	2006. 10.31 .

## **KYT 2300 Series Plastic Sheet Wrapped**

### **Card Dispenser**

### **(INTELLIGENT CARD DISPENSER)**

#### REVISION HISTORY

CHECK	DATE	DESCRIPTION	REV	PAGE
	2001.1.15	DC MOTOR (24V) Adopted.	C	
	2001.12.27	New B/D	D	20
	2003.11.3	Model	D	20
	2006.05.10	Main B/D Rev D	E	14
	2006.10.31	Modified the model name information in the SPEC.	F	15

<b>Doc No</b>	<b>KYX2300 SPECIFICATION</b>	<b>REV</b>	<b>PAGE</b>	<b>DATE</b>
		F	3 OF 15	2006. 10.31 .

## MODEL NAME INFORMATION

K Y  - 2 3

INTERFACE	FUNCTION	TYPE	CAPACITY	THICKNESS
T: RS-232C L: TTL	2: DISPENSER	3: SINGLE STACKER & WRAPPED CARD	1: 150 PCS 3: 300 PCS	1: 0.2T 2: 0.38T 3: 0.5T 4: 0.76T 5: 0.84T 6: 1.0T

<b>Doc No</b>	<b>KYX2300 SPECIFICATION</b>	<b>REV</b>	<b>PAGE</b>	<b>DATE</b>
			F	4 OF 15

## **C O N T E N T S**

- 1. Overview**
- 2. Features**
- 3. System Block Diagram**
- 4. Specification**
- 5. Connection Define**
- 6. Technical Drawing**
- 7. RS232C Interface**

<b>Doc No</b>	<b>KYX2300 SPECIFICATION</b>	<b>REV</b>	<b>PAGE</b>	<b>DATE</b>
			F	5 OF 15

## **1. Overview**

The KYX2300 Series is a family of the unit card dispenser especially designed for the Telephone Card, Chip Card vending machine, and the Card/Ticket wrapped up by the vinyl.

This Model is designed to protect from issuing two or more cards through the use of the clutch bearing and can be maintained with high reliability. With a competitive price, the KYX2300 Series can be used in various fields of industry such as a vending machine.

<b>Doc No</b>	<b>KYX2300 SPECIFICATION</b>	<b>REV</b>	<b>PAGE</b>	<b>DATE</b>
		F	6 OF 15	2006. 10.31 .

## 2. Features

1. Adjusting the terminal in accordance with the card width.
  - . Min 0.22 mm to Max 1.0 mm
2. Protecting from issuing two or more cards by using the clutch.
3. RS232C Interface
  - A. Selectable communication speed. (9,600 BPS ↔ 19,200BPS)
  - B. In issuing, the card location can be coordinated. (Only uni-direction)
  - C. The status checking is always available.
  - D. Easy to control.
4. TTL Interface
  - A. The card location can be coordinated by controlling the motor. (Only uni-direction)
  - B. Easy to control.

## 3. Dispenser Block Diagram

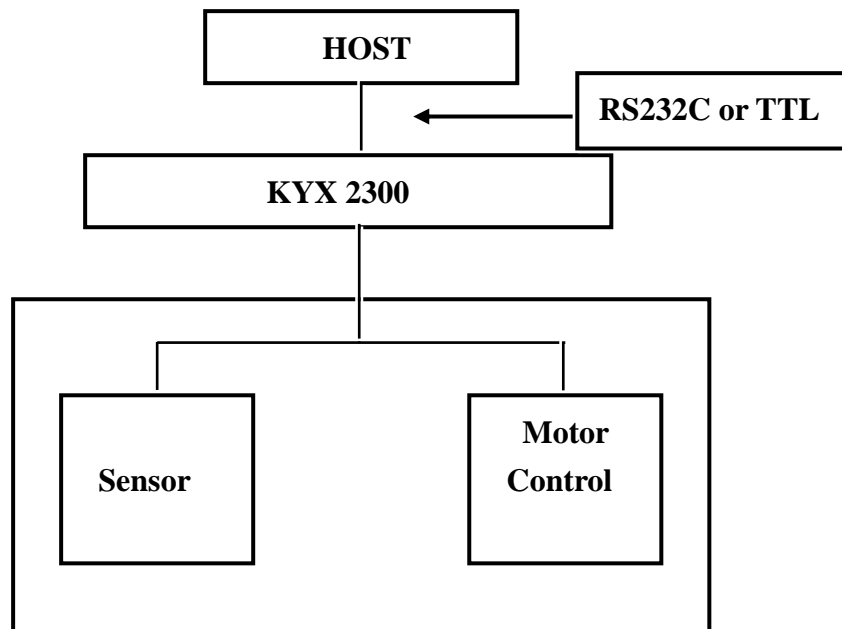

<b>Doc No</b>	<b>KYX2300 SPECIFICATION</b>	<b>REV</b>	<b>PAGE</b>	<b>DATE</b>
		F	7 OF 15	2006. 10.31 .

## 4. Specification

Model	KYT2310	KYL2310
Interface	RS232C	TTL
Microprocessor	O	X
Card Empty	O	O
Dimensions (W x L x H) mm	98.6 x 156 x215	
Card Dispensing Time (Sec)	1.5	
Max. Card Loading Capacity (In case of 0.76mm card)	150	
Total Weight (Kg)	1.7	
Applicable Cards	Phone Card, Credit, Debit, Pre-paid, I.C, R/F, Parking Card, etc.	
Card Material	P.V.C, A.B.S, P.E. Sheet, etc.	
Max. Card Width,Max. Card Length	Compliant with the ISO Standard.	
Max. Card Thickness	0.22 ~ 1.0 mm	
Supply Voltage & Current Consumption	Without Load : DC 24V(±5%) – 100 mA With Load : DC 24V (±5%)– 1500 mA	
Operating Humidity	0 % ~ 90 % RH	
Operating Temperature	-5° C ~ 70° C	
Place in Use	In the Cabinet	

## 5. Connection Definition

Model		KYT2310, KYL2340	
DC Power Connector	Part Number	5569-04A1(Molex)	
	Connector	J6	
	Pin	Figure 1	
Interface	Part Number	53015-031(Molex)	53015-610(Molex)
	Connector	J1	J2
	Pin	Figure 2	Figure 3
DC Motor Control			Figure 4

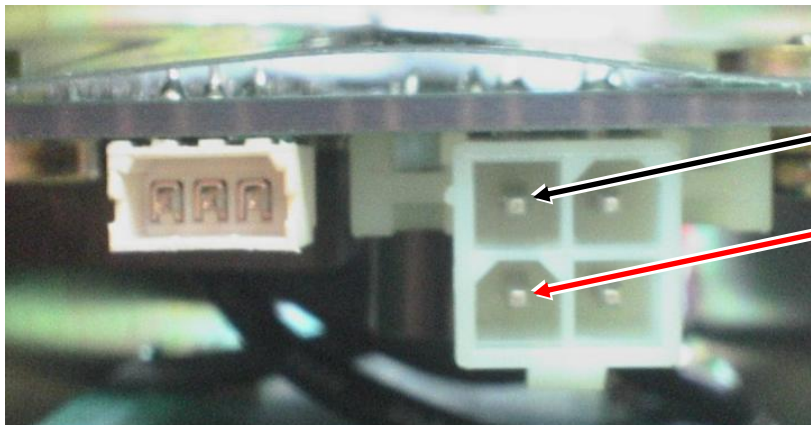

<b>Doc No</b>	<b>KYX2300 SPECIFICATION</b>	<b>REV</b>	<b>PAGE</b>	<b>DATE</b>
		F	8 OF 15	2006. 10.31 .

Pin NO	Signal Name	Cable color	Direction
1	GND	Black (or Green)	Input
2	Not use		
3	+24VDC	Yellow	
4	Not use		

**Figure 1. DC Power Connector (Male)**

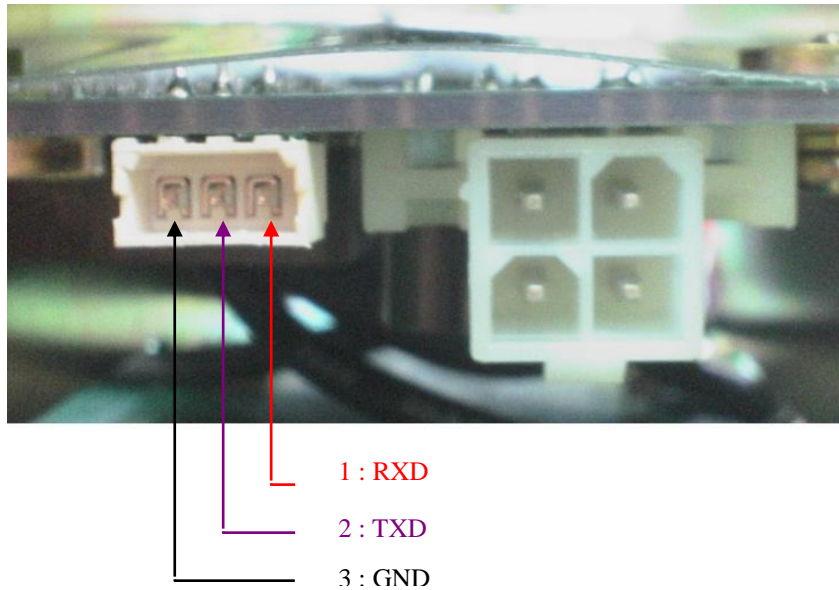

. Part Number : 53015-0310(Molex) , Connector(J1) Pin 1 ~ Pin 3.

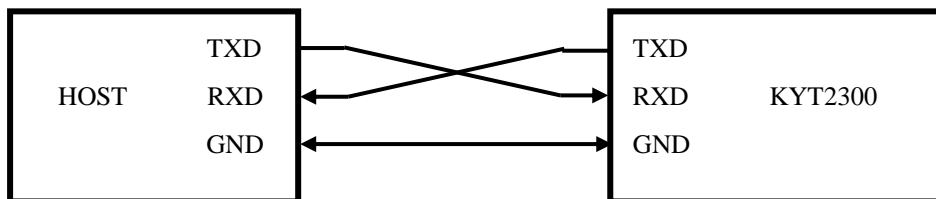

Pin No	INDEX	Remark
1	RXD	Receive
2	TXD	Transmit
3	GND	Signal Ground

**Figure 2. RS232C Connector (J1, Male)**



<b>Doc No</b>	<b>KYX2300 SPECIFICATION</b>	<b>REV</b>	<b>PAGE</b>	<b>DATE</b>
		F	9 OF 15	2006. 10.31 .

. Connector signal table

No	Signal Name	Input/Output	Function	Configuration
1	MOTOR_ENA	Input		
2	MOTOR_A	Input		
3	MOTOR_B	Input		
4	FINISH SENSOR	Output	Detected by sensor	Active High
5	EMPTY_SW	Output	Card Empty	Active Low
6	GND(Common)	Output		

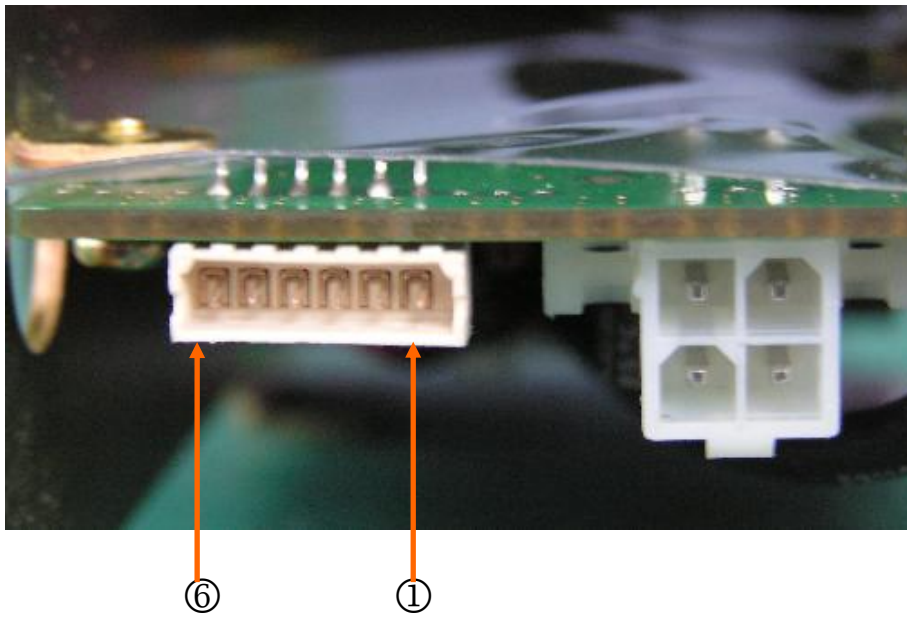

**Figure 3. TTL Connector (J2, Male)**

INPUTS			FUNCTION
MOTOR_ENA	MOTOR_A	MOTOR_B	
H	L	High	Motor Regular Direction
H	H	Low	Motor Reverse Direction
H	MOTOR_A = MOTOR_B		Fast Motor Stop
L	X	X	Feed Running Motor Stop

H : HIGH

L : LOW

C : Don't Care

**Figure 4. D.C Motor Control Table**

<b>Doc No</b>	<b>KYX2300 SPECIFICATION</b>	<b>REV</b>	<b>PAGE</b>	<b>DATE</b>
		F	10 OF 15	2006. 10.31 .

## 6. Technical Drawing.

### 6.1.1. KYT2310,KYL2310

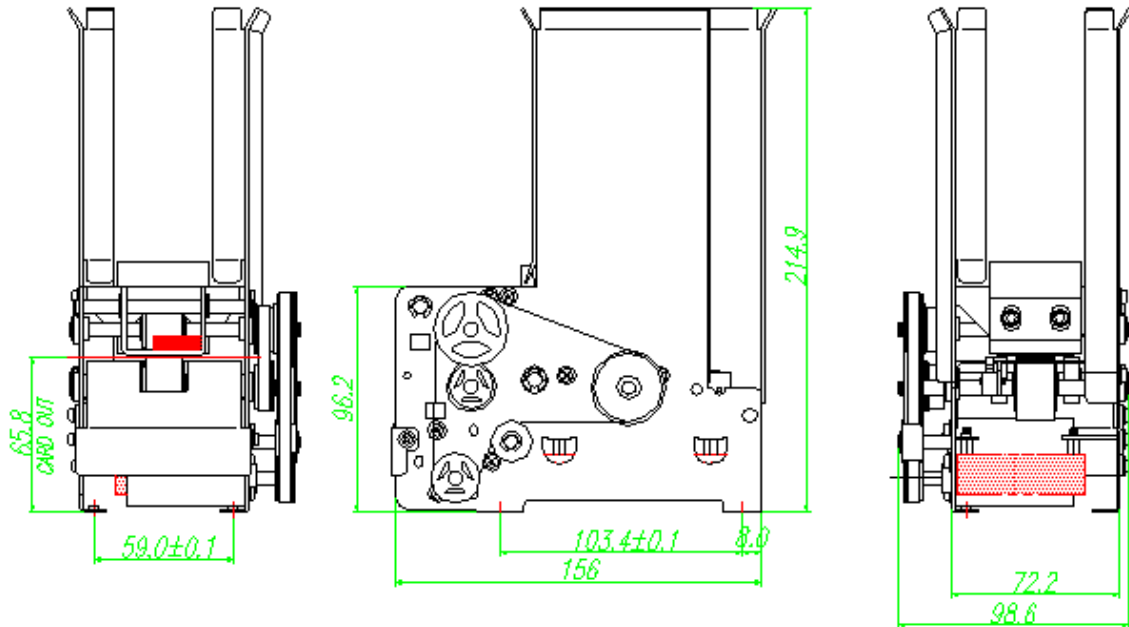

## 7. RS232C Interface.

### 7.1. Control Characters

NANE	Hex Value	Description
STX	02	Start of Text
ETX	03	End of Text
EOT	04	End of Transmission
ENQ	05	Enquiry
ACK	06	Positive Acknowledge
NAK	15	Negative Acknowledge
CAN	18	Cancel

### 7.2. Communication Method

Asynchronous, Half duplex.

Baud Rate : 9600, 19200BPS (Default : 9600BPS)

Data Length : 8Bits

Parity : None

Stop Bit : 1Bit

<b>Doc No</b>	<b>KYX2300 SPECIFICATION</b>	<b>REV</b>	<b>PAGE</b>	<b>DATE</b>
		F	11 OF 15	2006. 10.31 .

### 7.3. Frame Format

#### 7.3.1. Command structure



#### 7.3.2. Response structure

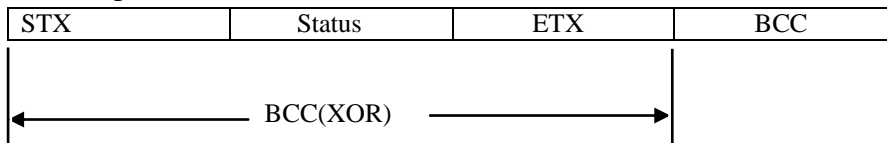

### 7.4. Communication Protocol Sequence

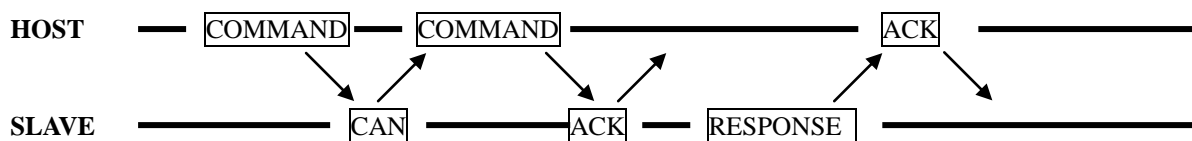
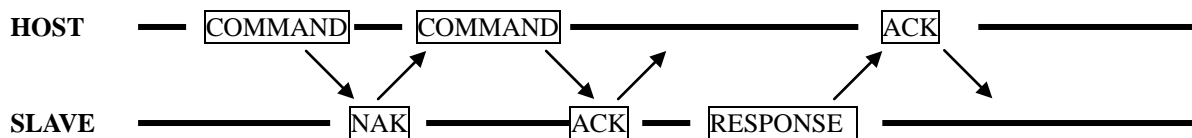
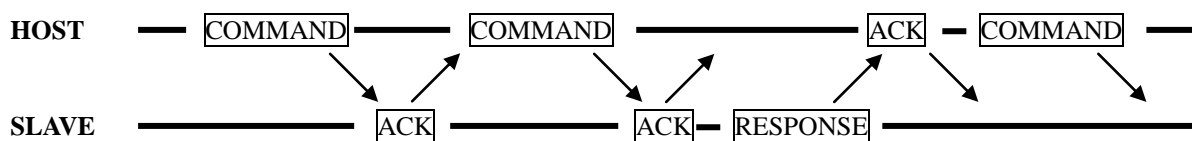
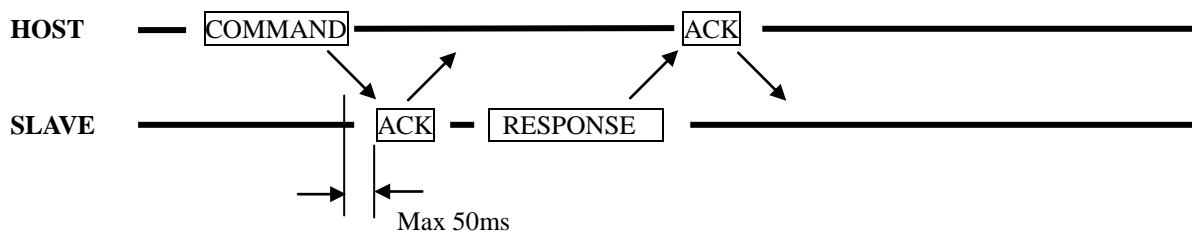
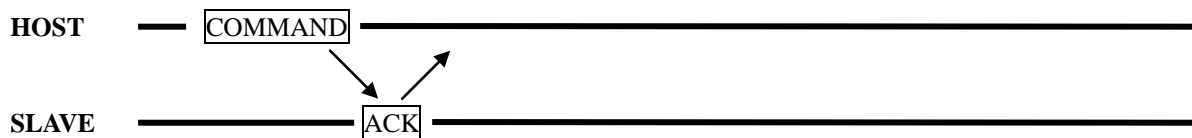

<b>Doc No</b>	<b>KYX2300 SPECIFICATION</b>	<b>REV</b>	<b>PAGE</b>	<b>DATE</b>
		F	12 OF 15	2006. 10.31 .

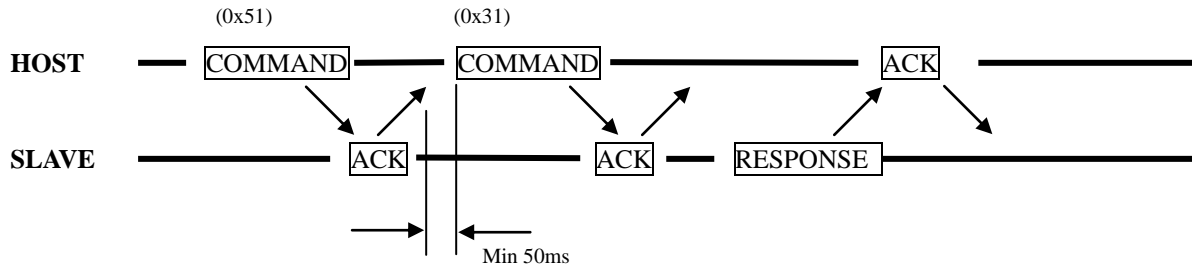

Note. To change Baud Rate, send a command 50ms after receiving ACK.

### 7.5. Command Sets List.

	Command	Description	Note
Clear	0x30	Error Bit Clear	
Request	0x31	Status Request	
Card Out	0x40	Issue	
Baud Rate Set	0x50	9600 BPS	
	0x51	19200 BPS	
Issuing Length Set	0xF0	Card drop (Default)	Refer to Page 16
	0xF1		
	0xF2		
	0xF3		
	0xF4		

### 7.6. Command Details

#### 7.6.1. Clear, Card Length, Baud Rate, Issue

Command Packet

STX	Command	ETX	BCC
-----	---------	-----	-----

#### 7.6.2. Status Request

: Host's Request for status of dispenser

Command Packet

STX	Command	ETX	BCC
-----	---------	-----	-----

Response Packet

STX	Status	ETX	BCC
-----	--------	-----	-----

<b>Doc No</b>	<b>KYX2300 SPECIFICATION</b>	<b>REV</b>	<b>PAGE</b>	<b>DATE</b>
		F	13 OF 15	2006. 10.31 .

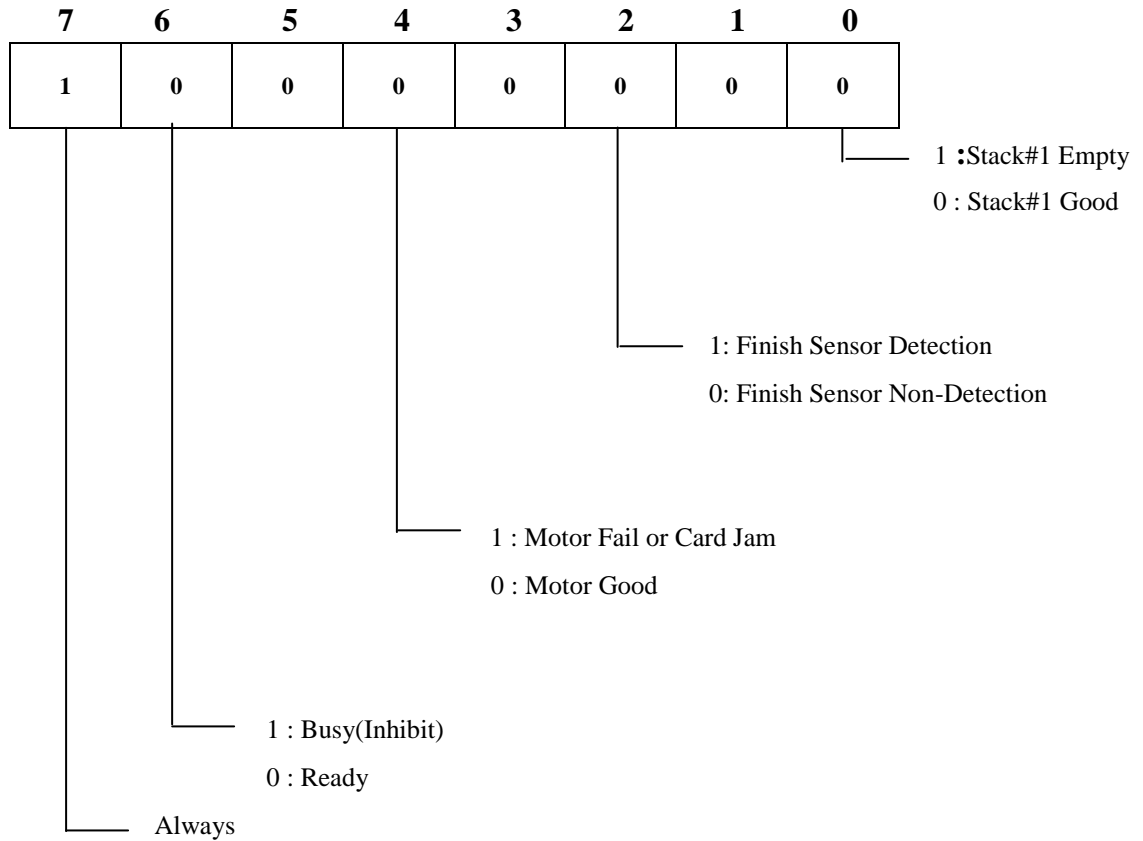

### 7.7. Issuing

: It starts to issue cards from Stacker

Command Packet

STX	Command	ETX	BCC
-----	---------	-----	-----

Note. The execution time of the KYT2310, KYT2330 is between 1.5 and 5 seconds at a maximum

Doc No	KYX2300 SPECIFICATION	REV	PAGE	DATE
		F	14 OF 15	2006. 10.31 .

### 7.8. Issue Length Set.

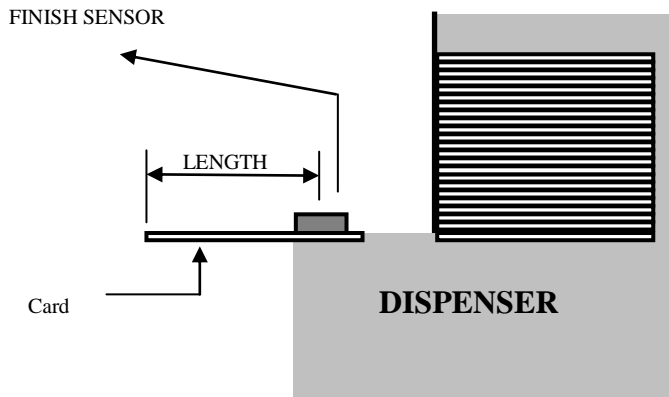

Commands to fix card length before dispensing a card .

- This is reserved as a fixed command and will be in operation until before power-off .
- If this command is not used , 0xF0 is set to be Default .
- To change this command while in operation , send a command after operation stops .
- This command is operable from 0xF0 to 0xF4 .

- . 0xF0 : Card Drop (Default).
- . 0xF1 : When issued, a card stops 2 mm away from finish sensor .
- . 0xF2 : When issued , a card stops 18mm away from finish sensor (-6 mm,+2 mm)
- . 0xF3 : When issued , a card stops 36mm away from finish sensor (-8 mm, +2 mm)
- . 0xF4 : When issued , a card stops 54mm away from finish sensor (-10 mm,+2 mm)

Doc No	KYX2300 SPECIFICATION	REV	PAGE	DATE
		F	15 OF 15	2006. 10.31 .

Example 1) KYT2310 RS232C Example.

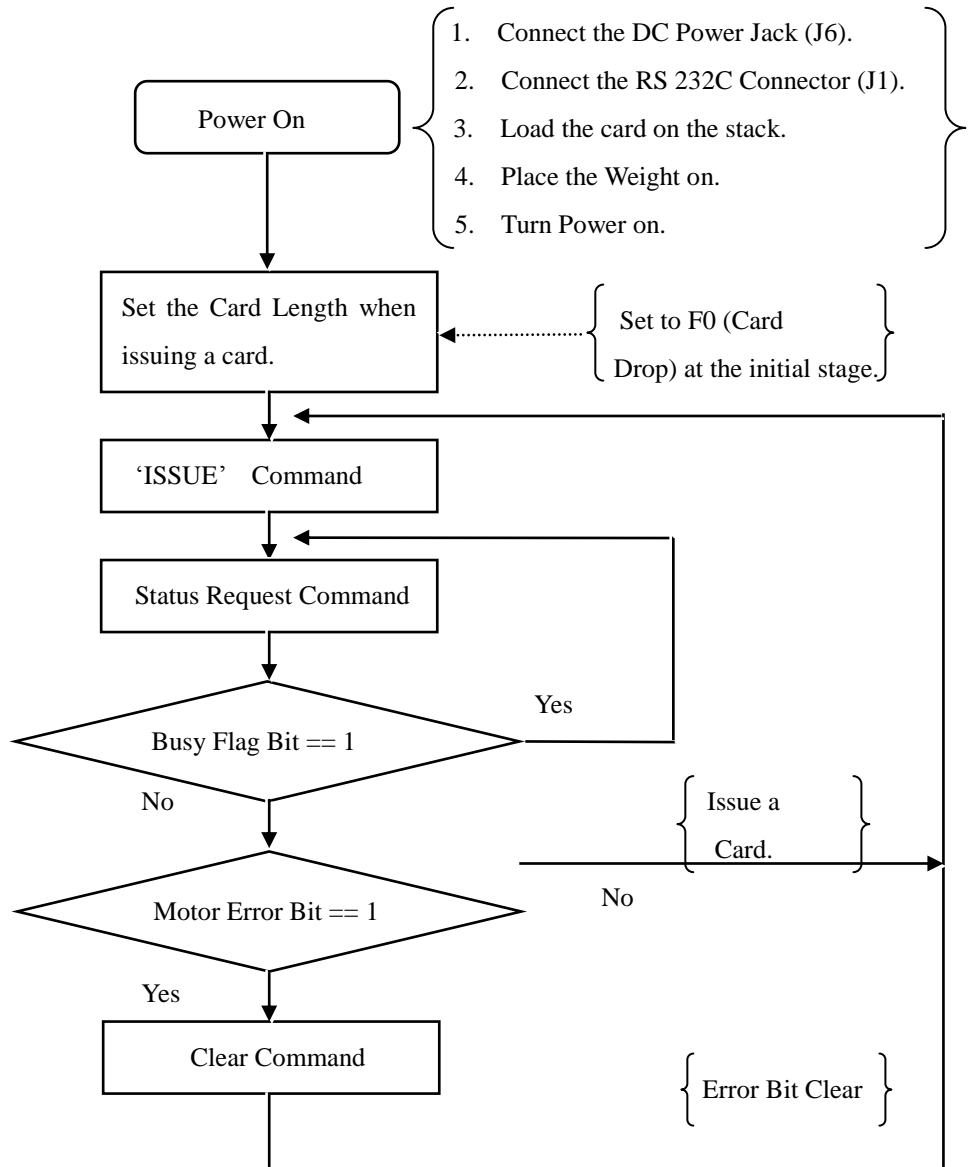

Doc No	KYX2300 SPECIFICATION	REV	PAGE	DATE
		F	16 OF 15	2006. 10.31 .

Example 2) KYL2310 TTL Example.

