



Ingeniería Electrónica
SMART IDENT

CARD ISSUING MACHINE

Specifications

User Manual

KYT-2500 Rev. A

Doc No	KYT2500 SERIES SPECIFICATION	REV	PAGE	DATE
			A	3 OF 17

C O N T E N T S

- 1. Overview**
- 2. Features**
- 3. System Block Diagram**
- 4. Specification**
- 5. Technical Drawing**
- 6. RS232C Interface**

Doc No	KYT2500 SERIES SPECIFICATION	REV	PAGE	DATE
		A	4 OF 17	2010. 05.04.

1. OVERVIEW

Card Dispenser KYT-2500 Series with clutch system to prevent 2 cards from being issued, has very compact and robust mechanism ,which leads to high reliability and easy-to-do maintenance.

It is easy to apply KYT-2500 to Card Vending Machine and other terminal products, bring price competitiveness to Users .

There are 2 types of Interface for KYT-2500 Series, TTL Interface and RS-232C Interface, which can be integrated as User requires .

Followings are major applications of KYT-2500 Series ;

- Phone Card Vending Machines
- Automatic Card Issuing Equipment
- Various Ticket Vending Machines
- Parking Equipment
- Access Control System
- Kiosk and etc.

Doc No	KYT2500 SERIES SPECIFICATION	REV	PAGE	DATE
		A	5 OF 17	2010. 05.04.

2. Features

1. Card thickness dispensable can be adjusted easily.
 - * Card thickness adjustable from 0.22mm up to 1.0mm
2. Prevents two (2) cards from being dispensed with clutch system
3. RS232C Interface
 - A. Baud Rate : changeable(9,600 BPS ↔ 19,200BPS)
 - B. Can change position of card (one way direction allowed)
 - C. With Self-diagnosis function
 - D. Easy to control
4. TTL Interface
 - A. Can control Motor to change position of card (one way direction allowed)
 - B. Easy to control

3. System Block Diagram

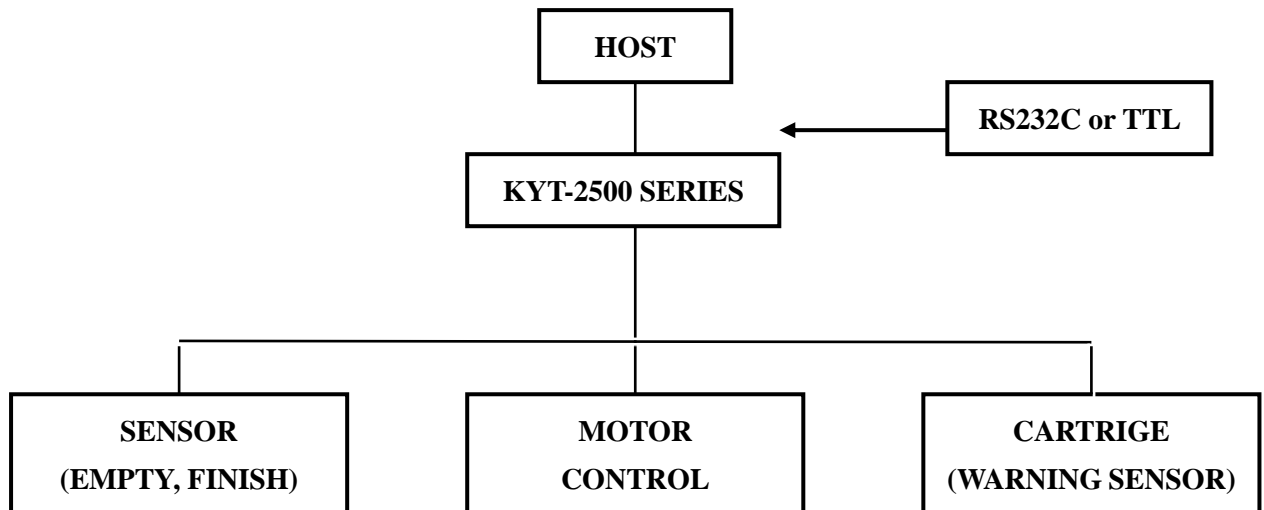

Doc No	KYT2500 SERIES SPECIFICATION	REV	PAGE	DATE
		A	6 OF 17	2010. 05.04.

4. Specification

MODEL	KYL-253X	KYT-253X	KYL-254X	KYT-254X
Interface	TTL	RS-232	TTL	RS-232
Dimensions (W x L x H) mm				
Card Dispensing Time (Sec)	1.5	1.5	1.5	1.8
Max. Card Loading Capacity (In case of 0.76 mm card)	300		500	
Total Weight (Kg)	1.8	1.9	2.0	2.2
Applicable Cards	Phone Card, Credit, Debit, Pre-paid, I.C, R/F, Parking Card, etc.			
Card Material	P.V.C, A.B.S, P.E.T, etc.			
Max. Card Width, Max. Card Length	ISO 7810			
Max. Card Thickness	0.22 ~ 1.0 mm			
Supply Voltage & Current Consumption	Without Load : DC 24V(±5%) – 50mA With Load : DC 24V (±5%)– 1500mA			
Operating Humidity	0 % ~ 90 % RH			
Operating Temperature	-5° C ~ 70° C			
Locus	In the Cabinet			

- **Model Numbering Table**

KY □ – **25** □ □

Interface	Function	Option	Capacity	Thickness
T : RS-232C L : TTL	2 : Dispenser	5 : Single Cartridge	1 : - 2 : - 3 : 300 cards 4 : 500 cards	1 : 0.20 2 : 0.38 3 : 0.50 4 : 0.76 5 : 0.84 6 : 1.00

Doc No	KYT2500 SERIES SPECIFICATION	REV	PAGE	DATE
		A	7 OF 17	2010. 05.04.

4.1 DC Power

. Interface connector

- Part Number : 5557-04A, Manufacture : MOLEX

. Connector number : J6

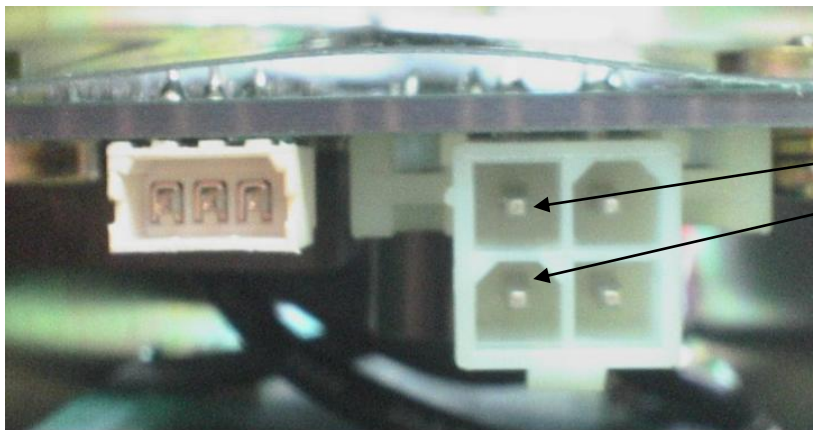

Pin NO	Signal Name	Cable color	Direction
1	GND	Black	Input
2	Not use		
3	+24VDC	Yellow	
4	Not use		

Doc No	KYT2500 SERIES SPECIFICATION	REV	PAGE	DATE
		A	8 OF 17	2010. 05.04.

4.2 Interface

4.2.1 RS232C type model

. Interface connector :

Part number : 51004-0310, Manufacture : MOLEX

When use the KYT-2500's com-cable, connect to twist cable.

When use the user's com-cable, connect to as bellows table

. Connector number : J1

. Connector signal table

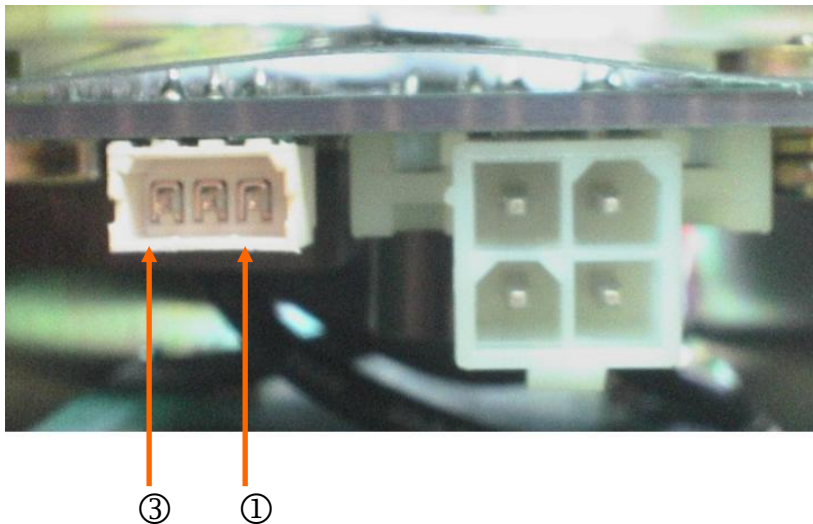

Pin No	Signal	KYT-2500	HOST	Dsub-9	Remark
1	RXD		←	3	Receive data
2	TXD	→		2	Transmit data
3	GND	↔		5	Signal Ground

. Communication Method

- Asynchronous, Half duplex.
- Communication speed : 9600, 19200BPS (Default : 9600BPS)
- Data Length : 8Bits
- Parity : None
- Stop Bit : 1Bit

Doc No	KYT2500 SERIES SPECIFICATION	REV	PAGE	DATE
		A	9 OF 17	2010. 05.04.

. Sensor definition

Connector No	NAME	Remark (As of KYT-2500)
J3	SEN1	Finish sensor
J4	SEN2	Warning
J5	SEN3	Empty sensor
J8	SEN4	optional
J9	SEN5	Optional

Doc No	KYT2500 SERIES SPECIFICATION	REV	PAGE	DATE
		A	10 OF 17	2010. 05.04.

4.2.2 TTL type model

.Interface connector :

Part number : 51004-1010, Manufacture : MOLEX

. Connector number : J1-1

. Connector signal table

No	Signal Name	Input/Output	Function	Configuration
1	MOTOR_ENA	INPUT		
2	MOTOR_A	INPUT		
3	MOTOR_B	INPUT		
4	FINISH SENSOR	OUTPUT	Detected by sensor	Active High
5	EMPTY_SW	OUTPUT	Stack Empty	Active Low
6	GND(Common)	OUTPUT		
7	WARNING	OUTPUT	Stack Warning	Active High
8	-	-	-	-
9	CARTRIDGE CONTACT	OUTPUT		Active High

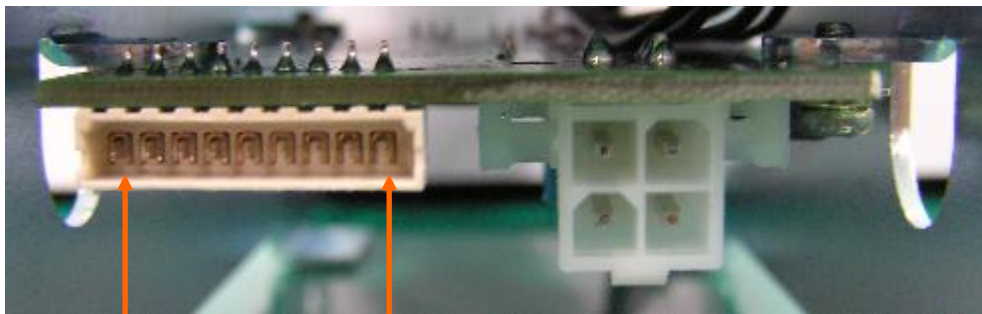

⑨

①

. D.C Motor Control Table

INPUTS			FUNCTION
MOTOR_ENA	MOTOR_A	MOTOR_B	
H	L	High	Motor Regular Direction
H	H	Low	Motor Reverse Direction
H	MOTOR_A = MOTOR_B		Fast Motor Stop
L	X	X	Feed Running Motor Stop

H : HIGH

L : LOW

C : Don't Care

Doc No	KYT2500 SERIES SPECIFICATION	REV	PAGE	DATE
		A	11 OF 17	2010. 05.04.

5. Technical Drawing

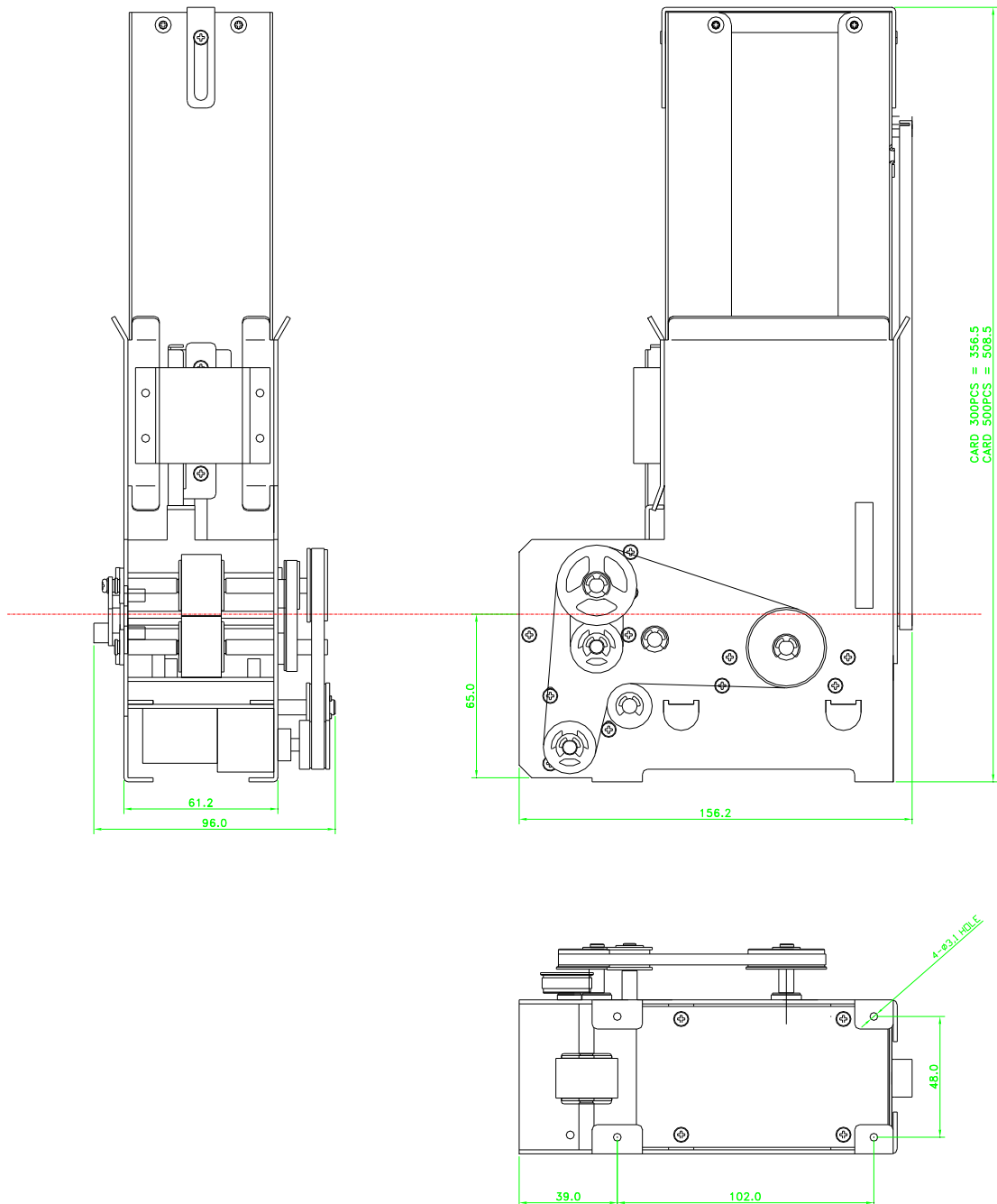

Doc No	KYT2500 SERIES SPECIFICATION	REV	PAGE	DATE
		A	12 OF 17	2010. 05.04.

6. RS232C Interface

6.1. Control Characters

NANE	Hex Value	Description
STX	02	Start of Text
ETX	03	End of Text
EOT	04	End of Transmission
ENQ	05	Enquiry
ACK	06	Positive Acknowledge
NAK	15	Negative Acknowledge
CAN	18	Cancel

6.2. Frame Format

1. Command structure

STX	Command	ETX	BCC
-----	---------	-----	-----

2. Response structure

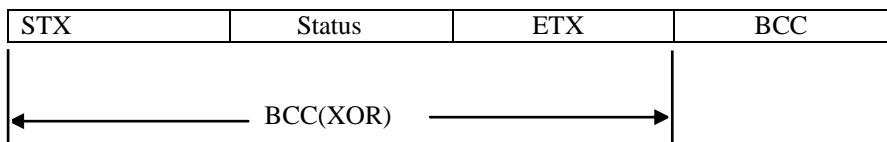

6.3. Communication Protocol Sequence

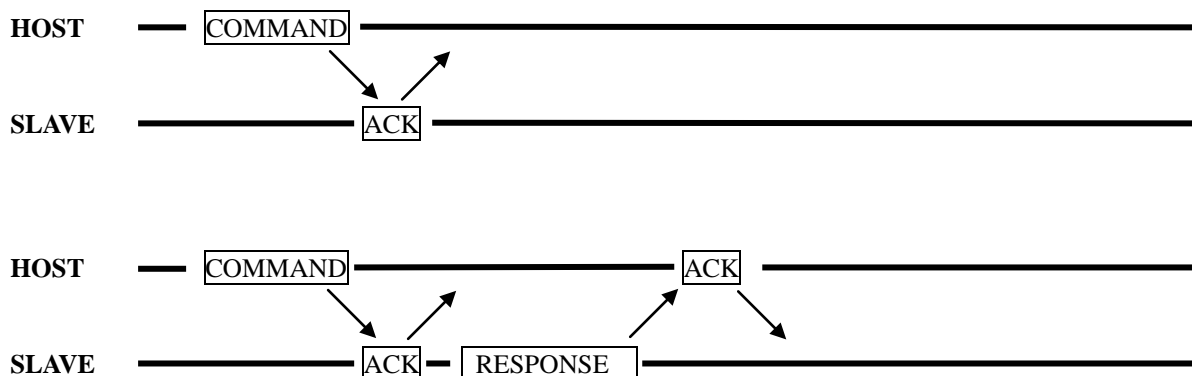

Doc No	KYT2500 SERIES SPECIFICATION	REV	PAGE	DATE
		A	13 OF 17	2010. 05.04.

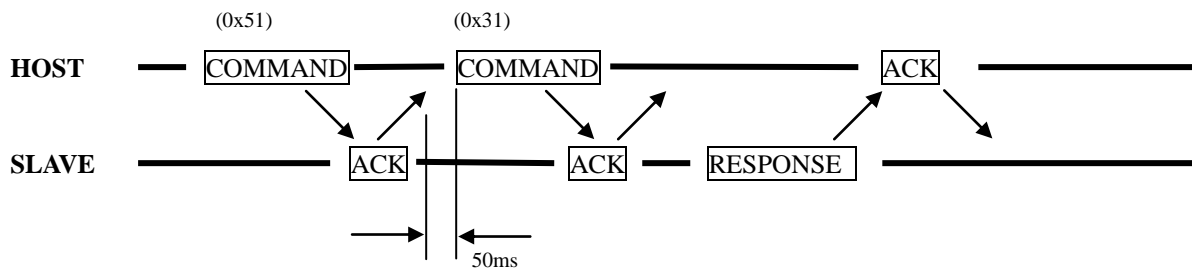
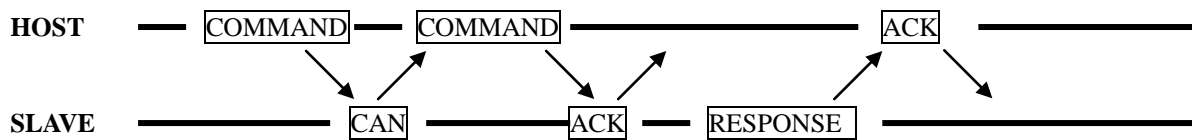
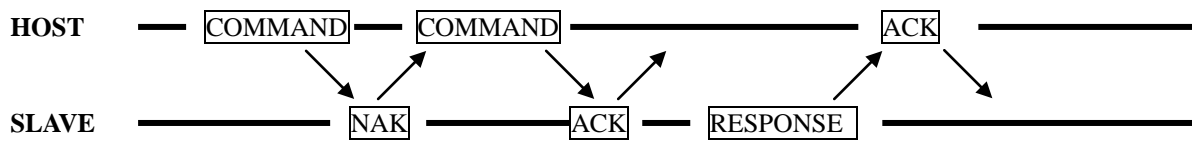
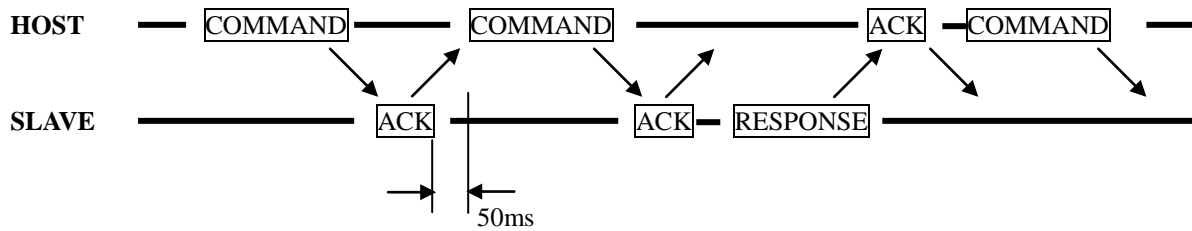

cf) To change Baud Rate , send command 50mS after receiving ACK .

6.4. Command Sets List

	Command	Description	Note
Clear	0x30	Error Clear	
Request	0x31	Status Request	
Issuing	0x40	Card Out	
Baud Rate Set	0x50	9600 BPS	
	0x51	19200 BPS	
Issuing Length Set	0xF0	Card drop (Default)	Refer to Page 13
	0xF1		
	0xF2		
	0xF3		
	0xF4		

Doc No	KYT2500 SERIES SPECIFICATION	REV	PAGE	DATE
		A	14 OF 17	2010. 05.04.

6.5. Command Details

1. Clear, Card Length

: Initializing Parameters(Initializing Error Bit)

Command Packet

STX	Command	ETX	BCC
-----	---------	-----	-----

2. Status Request

: Host's Request for status of dispenser

Command Packet

STX	Command	ETX	BCC
-----	---------	-----	-----

Response Packet

STX	Status	ETX	BCC
-----	--------	-----	-----

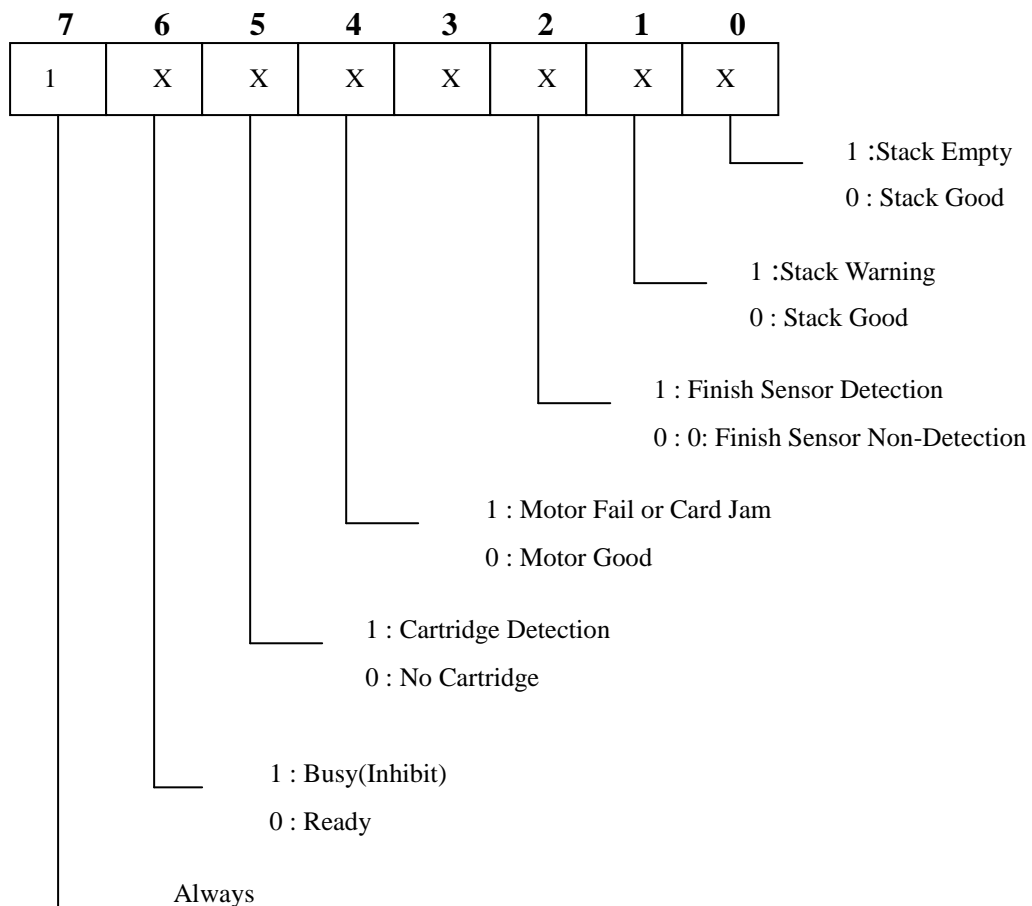

Doc No	KYT2500 SERIES SPECIFICATION	REV	PAGE	DATE
		A	15 OF 17	2010. 05.04.

3. Issuing

: It starts to issue cards from Stacker

Command Packet

STX	Command	ETX	BCC
-----	---------	-----	-----

Ref) It takes 1.5 sec to 5 Sec to dispense a card.

4. Card Issuing Length Set. Commands (Ref. 6.4 Commands Set List on Page 12)

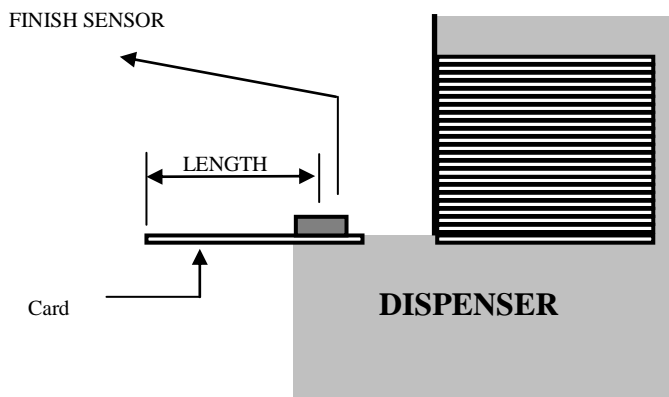

Commands to fix card length before dispensing a card .

- This is reserved as a fixed command and will be in operation until before power-off .
- If this command is not used , 0xF0 is set to be Default .
- To change this command while in operation , send a command after operation stops .
- This command is operable from 0xF0 to 0xF4 .

- . 0xF0 : Card Drop (Default).
- . 0xF1 : When issued, a card stops 3 mm away from finish sensor .
- . 0xF2 : When issued , a card stops 18mm away from finish sensor (-5 mm,+1.5 mm)
- . 0xF3 : When issued , a card stops 36mm away from finish sensor (-8 mm, +1.5 mm)
- . 0xF4 : When issued , a card stops 54mm away from finish sensor (-10 mm,+1.5 mm)

Doc No	KYT2500 SERIES SPECIFICATION	REV	PAGE	DATE
		A	16 OF 17	2010. 05.04.

Example 1) RS232 Control Example

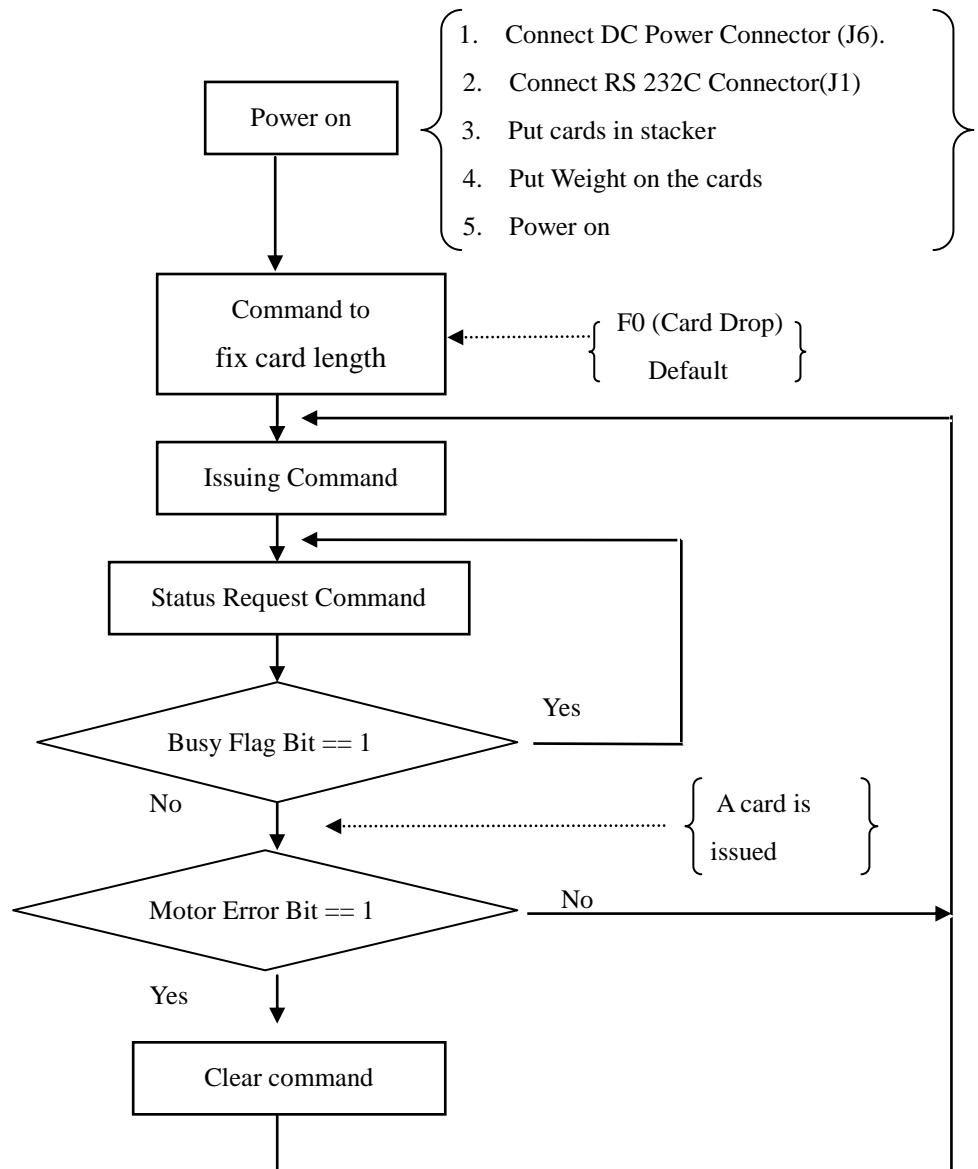

Doc No	KYT2500 SERIES SPECIFICATION	REV	PAGE	DATE
		A	17 OF 17	2010. 05.04.

Example 2) TTL Control Example

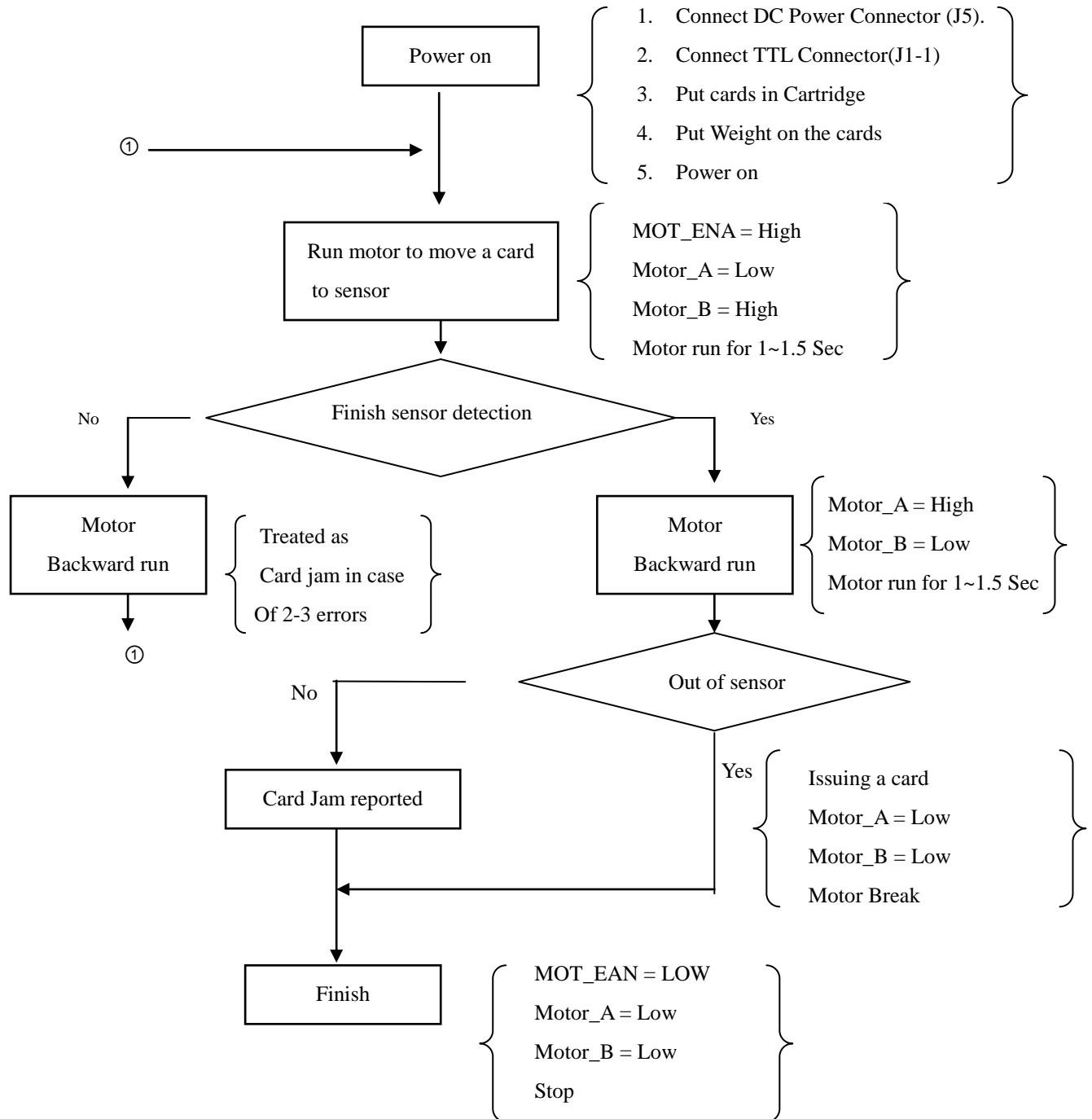

Doc No	KYT2500 SERIES SPECIFICATION	REV	PAGE	DATE
		A	18 OF 17	2010. 05.04.

* SENSOR NAME

