



Ingeniería Electrónica
SMART IDENT

KYT-2100/KYL-2100 CARD ISSUING MACHINE Specifications

User Manual

KYX2100.UM.L.EN.doc

Doc No	KYX21XX SERIES SPECIFICATION	REV	PAGE	DATE
91000230-00		L	2 OF 23	2013. 06. 17.

REVISION HISTORY

CHECK	DATE	DESCRIPTION	REV	PAGE
	2001/10/16		C	16
	2001/11/19	DC Power, TTL, RS232C Connector	C	15
	2003/01/29	DC Power	C	15
	2005/03/24	Apply to REV.B B'D	D	15
	2005/09/01	Added KYX2114 Model	E	15
	2006/03/17	TTL Interface (MOT_ENA) Add	F	15
	2006/07/22	MAIN B/D REV_D(ROHS)	G	15
	2007/07/11	Finish Sensor Addition.	H	19
	2007/11/27	Rom version check function addition.	I	20
	2009/03/18	Warning Sensor Addition.	J	21
	2012/07/18	Added the DC power Jack	K	21
	2013/06/17	Dimension / Model table	L	21

Doc No	KYX21XX SERIES SPECIFICATION	REV	PAGE	DATE
91000230-00		L	3 OF 23	2013. 06. 17.

C O N T E N T S

- 1. Overview**
- 2. Features**
- 3. System Block Diagram**
- 4. Specification**
- 5. Technical Drawing**
- 6. RS232C Interface**

Doc No	KYX21XX SERIES SPECIFICATION	REV	PAGE	DATE
91000230-00		L	4 OF 23	2013. 06. 17.

1. OVERVIEW

Card Dispenser KYT-2100 Series with clutch system to prevent 2 cards from being issued, has very compact and robust mechanism ,which leads to high reliability and easy-to-do maintenance.

It is easy to apply KYT-2100 to Card Vending Machine and other terminal products, bring price competitiveness to Users .

There are 2 types of Interface for KYT-2100 Series, TTL Interface and RS-232C Interface, which can be integrated as User requires .

Followings are major applications of KYT-2100 Series;

- Phone Card Vending Machines
- Automatic Card Issuing Equipment
- Various Ticket Vending Machines
- Parking Equipment
- Access Control System
- Kiosk and etc.

Doc No	KYX21XX SERIES SPECIFICATION	REV	PAGE	DATE
91000230-00		L	5 OF 23	2013. 06. 17.

2. Features

1. Card thickness dispensable can be adjusted easily.
 - * Card thickness adjustable from 0.22mm up to 1.0mm
2. Prevents two (2) cards from being dispensed with clutch system
3. RS232C Interface
 - A. Baud Rate: changeable (9,600 BPS ↔ 19,200BPS)
 - B. Can change position of card (one way direction allowed)
 - C. With Self-diagnosis function
 - D. Easy to control
4. TTL Interface
 - A. Can control Motor to change position of card (one way direction allowed)
 - B. Easy to control

3. System Block Diagram

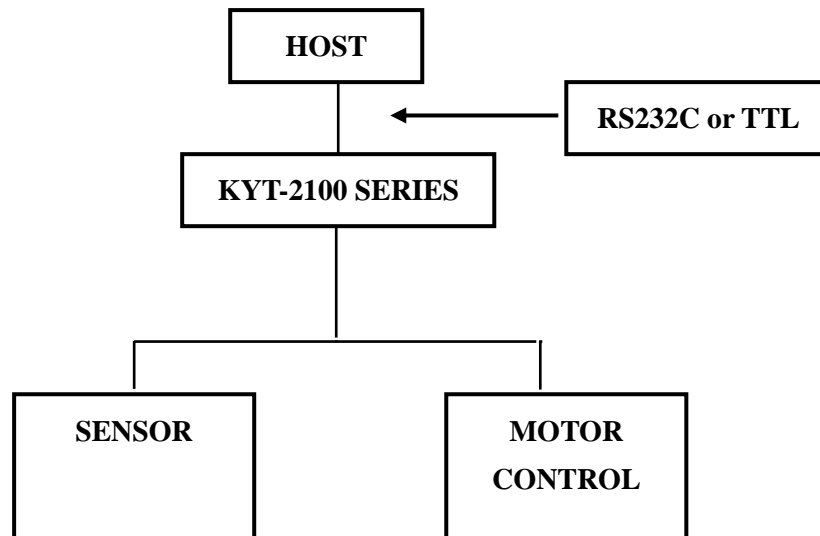

Doc No	KYX21XX SERIES SPECIFICATION	REV	PAGE	DATE
91000230-00		L	6 OF 23	2013. 06. 17.

4. Specification

MODEL	KYL-2114	KYT-2114	KYL-2124	KYT-2124	KYL-2134	KYT-2134	KYL-2144	KYT-2144
Interface	TTL	RS-232	TTL	RS-232	TTL	RS-232	TTL	RS-232
Microprocessor	X	O	X	O	X	O	X	O
Card Empty	O	O	O	O	O	O	O	O
Warning Sensor	X	X	X	X	X	X	O	O
Dimensions	82x145x149		82 x 145 x 235		82 x 145 x 315		82 x 145 x 465	
Card Dispensing Time	1.5 (Sec)		1.5(Sec)		1.5(Sec)		1.8(Sec)	
Max. Card Loading Capacity	(In case of 0.76 mm card) 100		(In case of 0.76 mm card) 200		(In case of 0.76 mm card) 300		(In case of 0.76 mm card) 500	
Total Weight (Kg)	1.8		1.9		2.0		2.2	
Applicable Cards	Phone Card, Credit, Debit, Pre-paid, I.C, R/F, Parking Card, etc.							
Card Material	P.V.C, A.B.S, P.E.T, etc.							
Max. Card Width, Max. Card Length	ISO 7810							
Max. Card Thickness	0.22 ~ 1.0 mm							
Supply Voltage & Current Consumption	Without Load: DC 24V(±5%) – 50mA With Load: DC 24V (±5%)– 1500mA							
Operating Humidity And Temperature	0~95% RH,0~40℃							
Conservation Hum- idity and Temperature	0~95% RH, -5~40℃							
Locus	In the Cabinet							

● Model Numbering Table

KY □ – **2 1** □ □ □ □

K Y – 2 1

INTERFACE	FUNCTION	TYPE	CAPACITY	THICKNESS	OPTION I	OPTION II
T: RS-232C L: TTL S: RS-422	2: DISPENSER	1: SINGLE STACKER	1: 100 PCS 2: 200 PCS 3: 300 PCS 4: 500 PCS	1 : 0.2T 2 : 0.38T 3 : 0.5T 4 : 0.76T 5 : 0.84T 6 : 1.0T	0 : - 1 : WARNING SENSOR	0 : - 1 : SHORT BEZEL 2 : SHUTTER 3 : SLIDE DROP

4.1 DC Power

Doc No	KYX21XX SERIES SPECIFICATION	REV	PAGE	DATE
91000230-00		L	7 OF 23	2013. 06. 17.

. Interface connector

- Part Number : 5557-04A, Manufacture : MOLEX

. Connector number: J6

Pin NO	Signal Name	Cable color	Direction
1	GND	Black (or Green)	Input
2	Not use		
3	+24V	Yellow	
4	Not use		

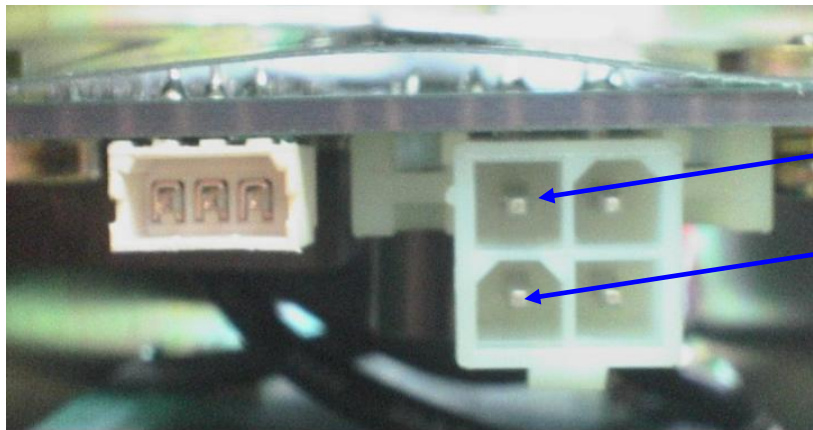

Pin 1. GND

Pin 3. +24V

6.2. Connector number: J7 (Option)

-DC Power Jack

Pin NO.	Signal Name	Direction
1	GND	Input
2	GND	
3	DC +24V	

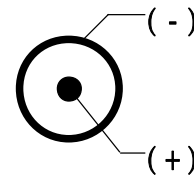

4.2 Interface

Doc No	KYX21XX SERIES SPECIFICATION	REV	PAGE	DATE
91000230-00		L	8 OF 23	2013. 06. 17.

4.2.1 RS232C type model

. Interface connector:

Part number: 51004-0310, Manufacture: MOLEX

When use the KYT-2100's com-cable, connect to twist cable.

When use the user's com-cable, connect to as bellows table

. Connector number: J1

. Connector signal table

Pin No	Signal	KYT-2100	HOST	Dsub-9	Remark
1	RXD	←		3	Receive data
2	TXD	→		2	Transmit data
3	GND	↔		5	Signal Ground

. Communication Method

- Asynchronous, Half duplex.
- Communication speed: 9600, 19200BPS (Default: 9600BPS)
- Data Length: 8Bits
- Parity: None
- Stop Bit: 1Bit

. Sensor definition

Connector No	NAME	Remark (As of KYT-2100)
J3	SEN1	Finish sensor
J4	SEN2	Finish additional sensor (optional)
J5	SEN3	Empty sensor
J8	SEN4	-
J9	SEN5	Warning sensor

4.2.2 TTL type model

Doc No	KYX21XX SERIES SPECIFICATION	REV	PAGE	DATE
91000230-00		L	9 OF 23	2013. 06. 17.

.Interface connector:

Part number: 51004-0610, Manufacture: MOLEX

. Connector number: J1-1

. Connector signal table (Old)

No.	Signal Name	Input /Output	Function	Configuration
1	MOTOR_ENA	Input		
2	MOTOR_A	Input		
3	MOTOR_B	Input		
4	FINISH SENSOR	Output	Detected by sensor	Active High
5	EMPTY_SW	Output	Card Empty	Active Low
6	GND(Common)	Output		

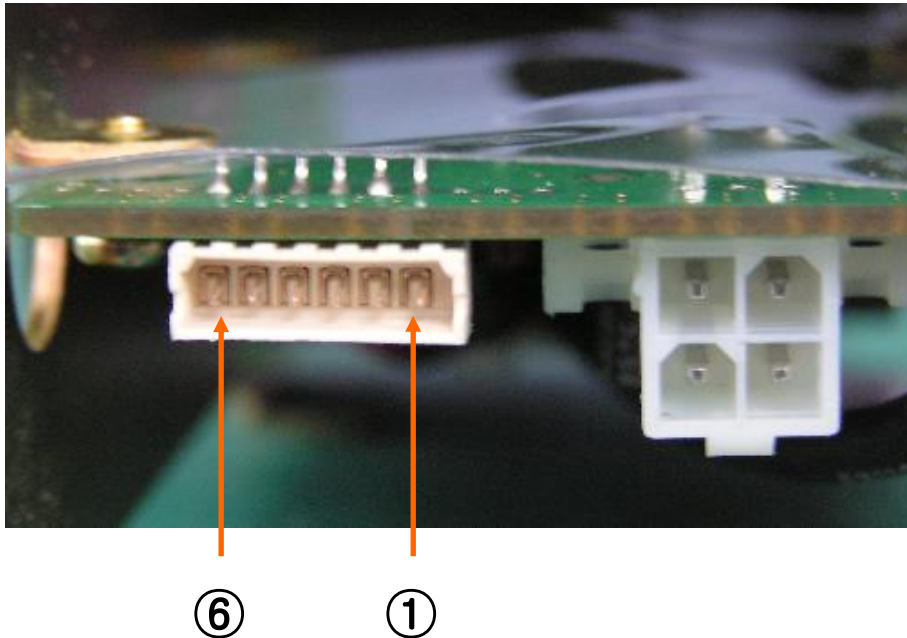

. Connector signal table (New: effective July, 7, 2007)

Doc No	KYX21XX SERIES SPECIFICATION	REV	PAGE	DATE
91000230-00		L	10 OF 23	2013. 06. 17.

No	Signal Name	Input /Output	Function	Configuration
1	MOTOR_ENA	Input		
2	MOTOR_A	Input		
3	MOTOR_B	Input		
4	FINISH SENSOR(Left)	Output	Detected by sensor	Active High
5	EMPTY_SW	Output	Card Empty	Active Low
6	GND(Common)	Output		
7	FINISH SENSOR(Right : Addition)	Output	Detected by sensor	Active High

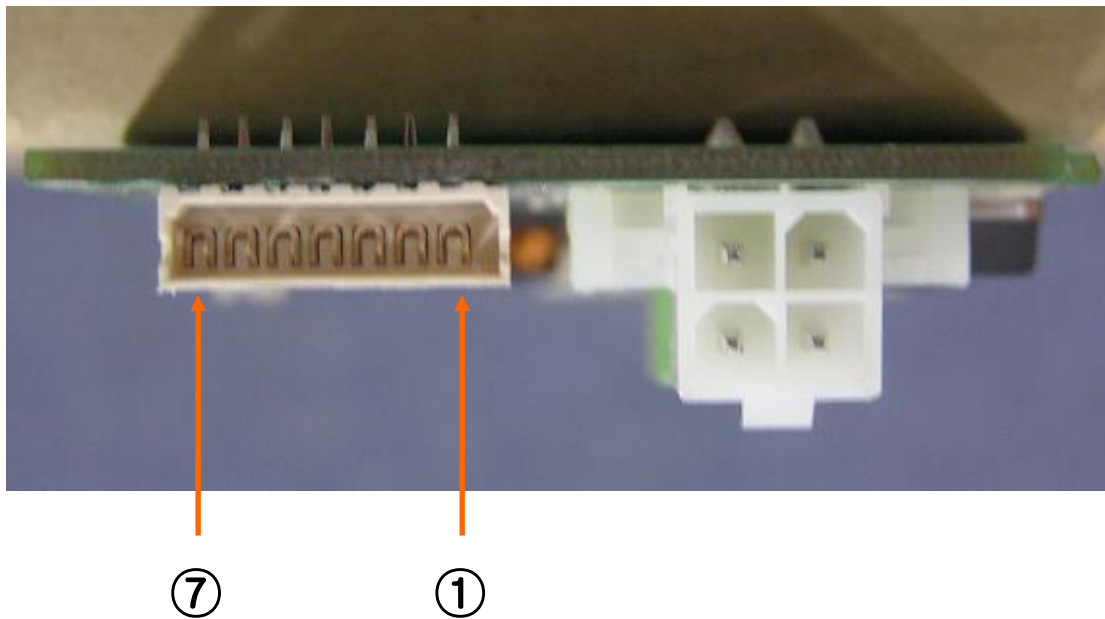

. Connector signal table (New: effective March, 7, 2009)

Doc No	KYX21XX SERIES SPECIFICATION	REV	PAGE	DATE
91000230-00		L	11 OF 23	2013. 06. 17.

No	Signal Name	Input /Output	Function	Configuration
1	MOTOR_ENA	Input		
2	MOTOR_A	Input		
3	MOTOR_B	Input		
4	FINISH SENSOR(Left)	Output	Detected by sensor	Active High
5	EMPTY_SW	Output	Detected by sensor	Active High
6	GND(Common)	Output		
7	FINISH SENSOR(Right)	Output	Detected by sensor	Active High
8	-	-	-	-
9	WARNING SENSOR	Output	Detected by sensor	Active Low
10	-	-	-	-

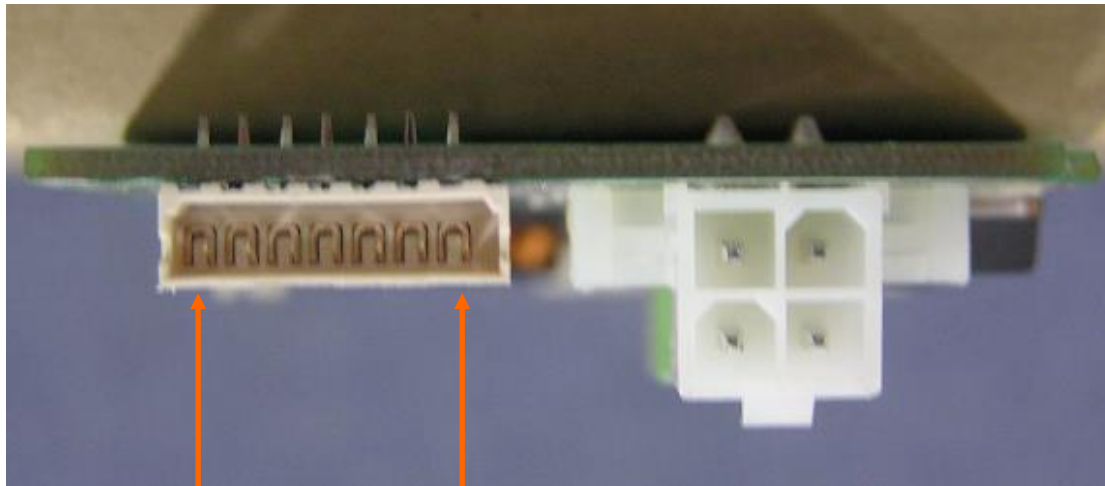

10 PIN

1 PIN

. D.C Motor Control Table

INPUTS			FUNCTION
MOTOR_ENA	MOTOR_A	MOTOR_B	
H	L	H	Motor Regular Direction
H	H	L	Motor Reverse Direction
H	MOTOR_A = MOTOR_B		Fast Motor Stop
L	X	X	Feed Running Motor Stop

H: HIGH

L: LOW

X: Don't Care

* SENSOR B/D (FINISH SENSOR)

TTL B/D

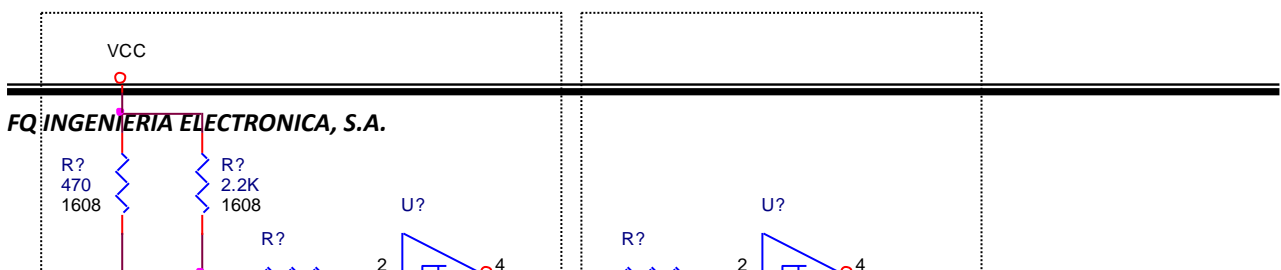

Doc No	KYX21XX SERIES SPECIFICATION	REV	PAGE	DATE
91000230-00		L	12 OF 23	2013. 06. 17.

* Card detected signal

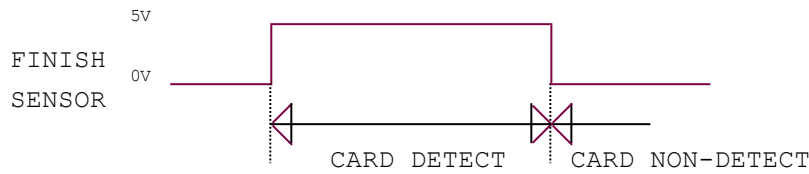

* SENSOR B/D (EMPTY SENSOR)

TTL B/D

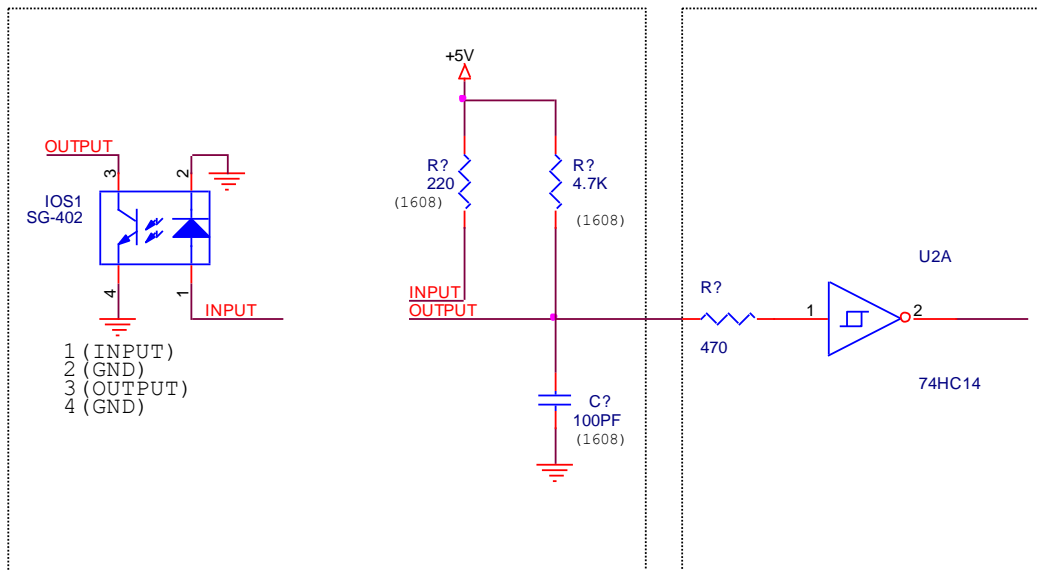

* MOTOR

Doc No	KYX21XX SERIES SPECIFICATION	REV	PAGE	DATE
91000230-00		L	13 OF 23	2013. 06. 17.

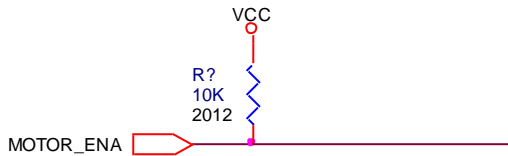
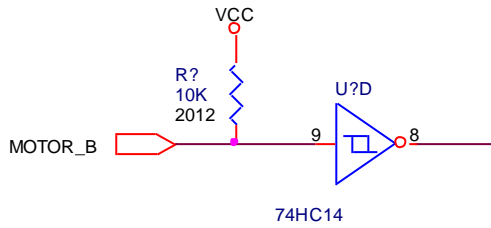
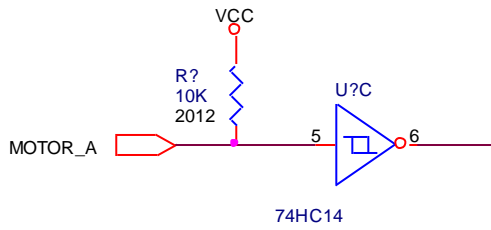

*** Motor Regular Direction Signal**

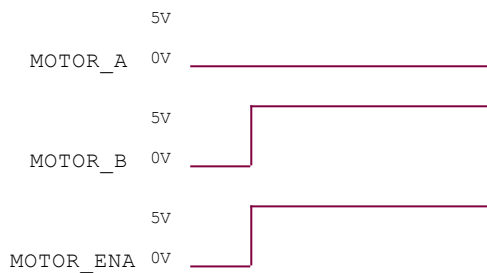

*** Motor Reverse Direction Signal**

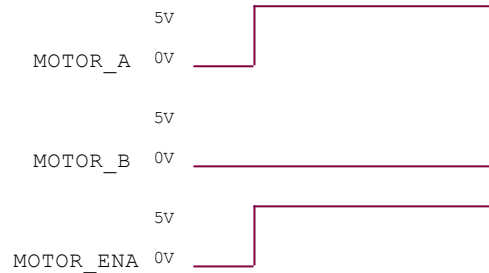

*** Fast Motor Stop Signal**

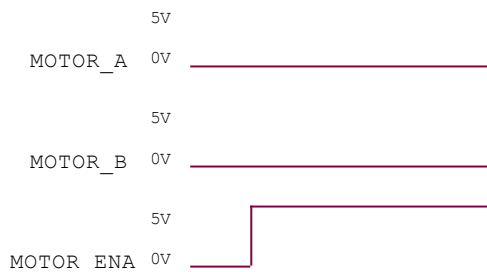

*** Feed Running Motor Stop Signal**

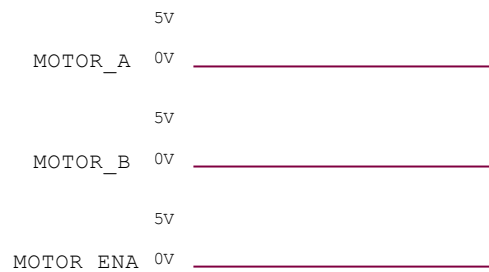

Doc No	KYX21XX SERIES SPECIFICATION	REV	PAGE	DATE
91000230-00		L	14 OF 23	2013. 06. 17.

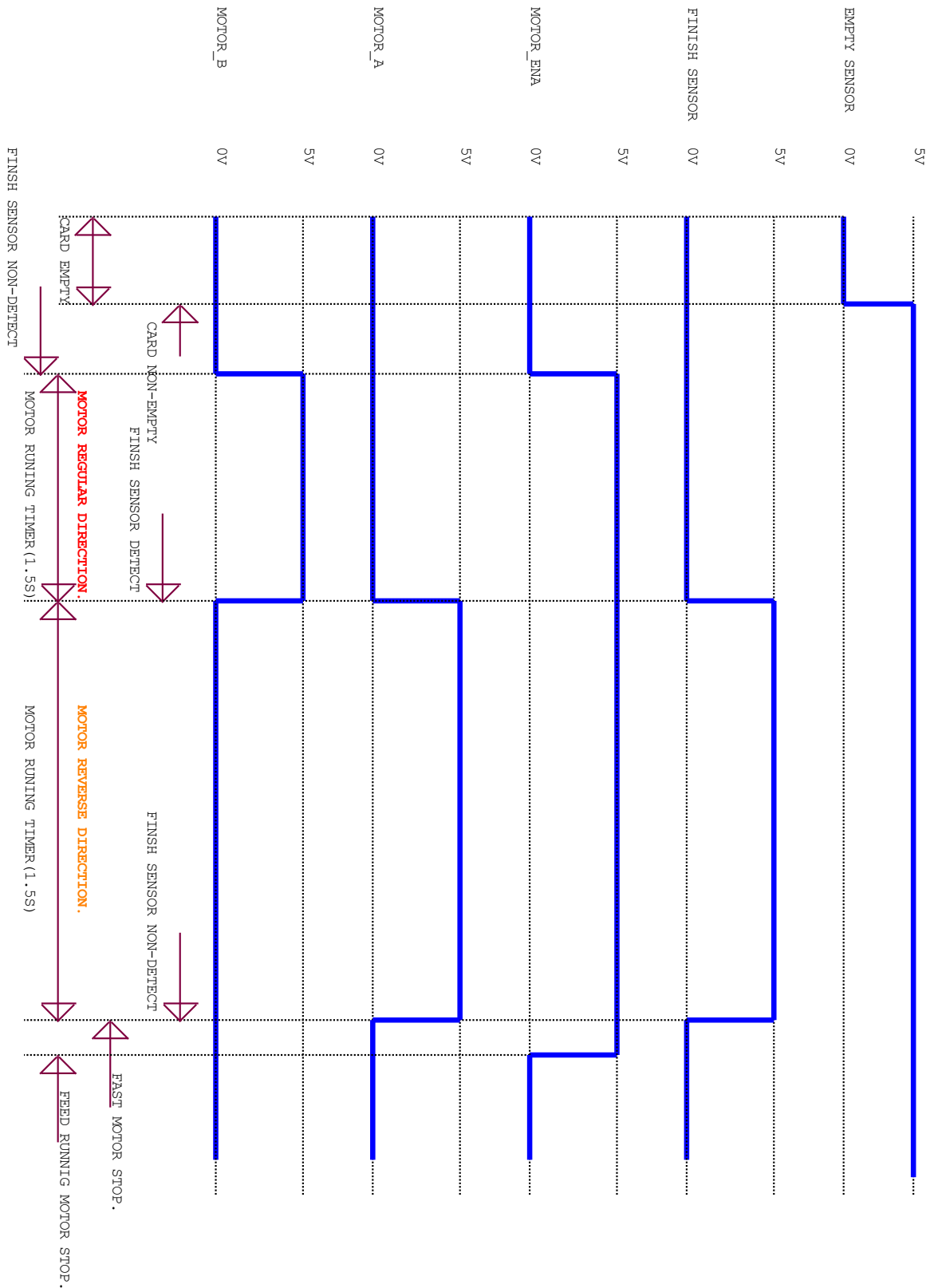

Doc No	KYX21XX SERIES SPECIFICATION	REV	PAGE	DATE
91000230-00		L	15 OF 23	2013. 06. 17.

5. Technical Drawing

5.1. KYT-21XX

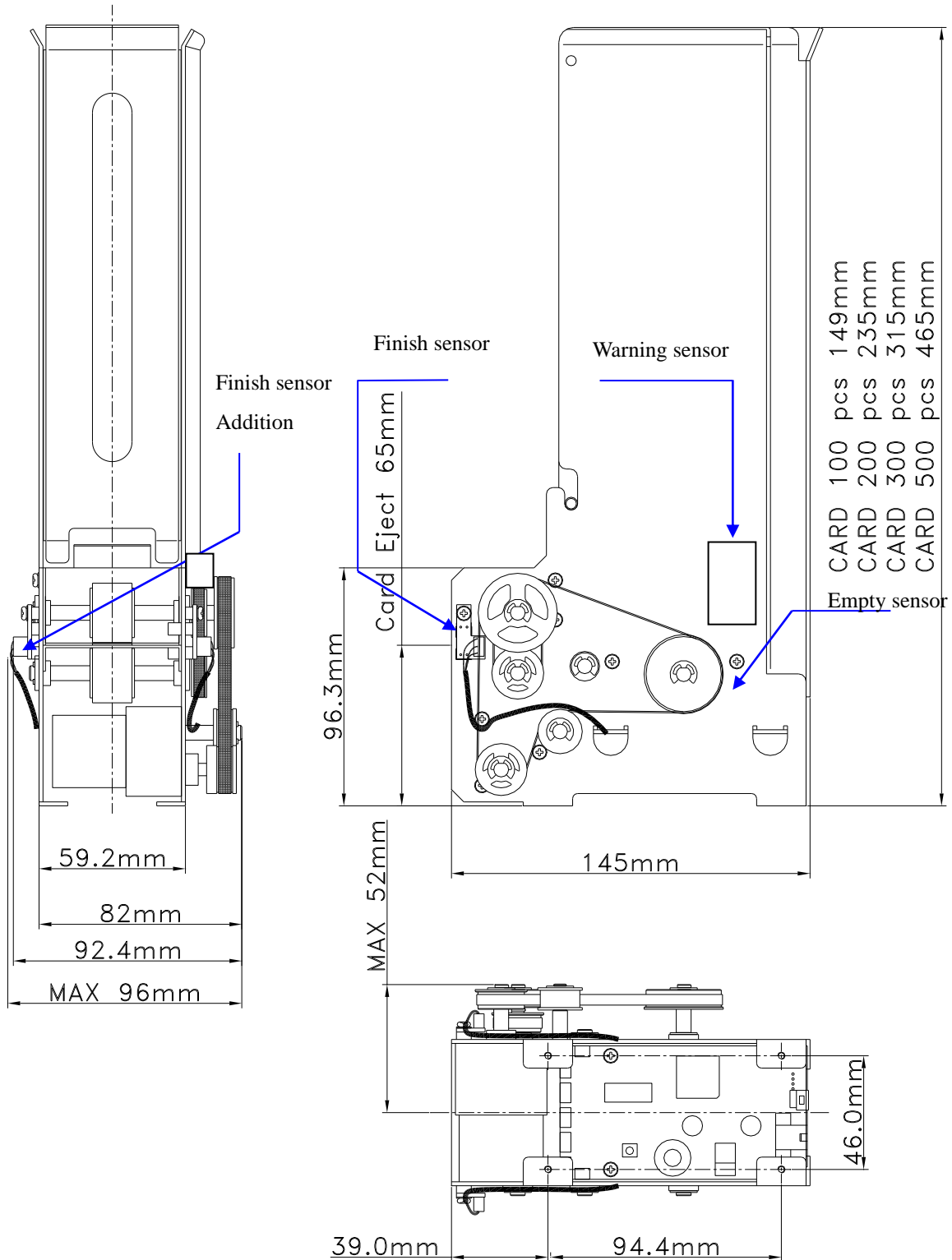

Doc No	KYX21XX SERIES SPECIFICATION	REV	PAGE	DATE
91000230-00		L	16 OF 23	2013. 06. 17.

5.2. KYT-21XX (DROP TYPE)

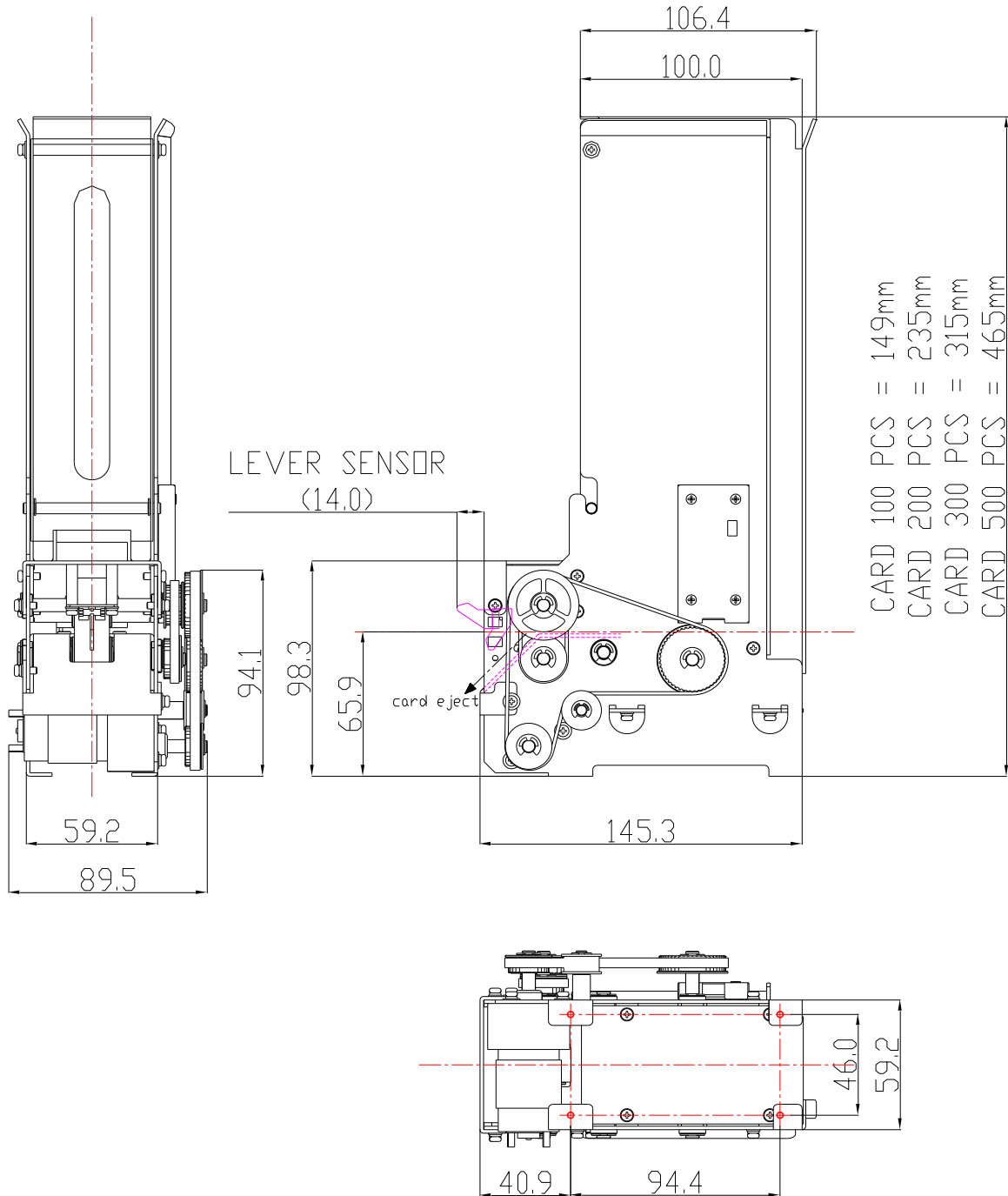

Doc No	KYX21XX SERIES SPECIFICATION	REV	PAGE	DATE
91000230-00		L	17 OF 23	2013. 06. 17.

6. RS232C Interface

6.1. Control Characters

Name	Hex Value	Description
STX	02	Start of Text
ETX	03	End of Text
EOT	04	End of Transmission
ENQ	05	Enquiry
ACK	06	Positive Acknowledge
NAK	15	Negative Acknowledge
CAN	18	Cancel

6.2. Frame Format

1. Command structure

STX	Command	ETX	BCC
-----	---------	-----	-----

2. Response structure

STX	Status	ETX	BCC
-----	--------	-----	-----

6.3. Communication Protocol Sequence

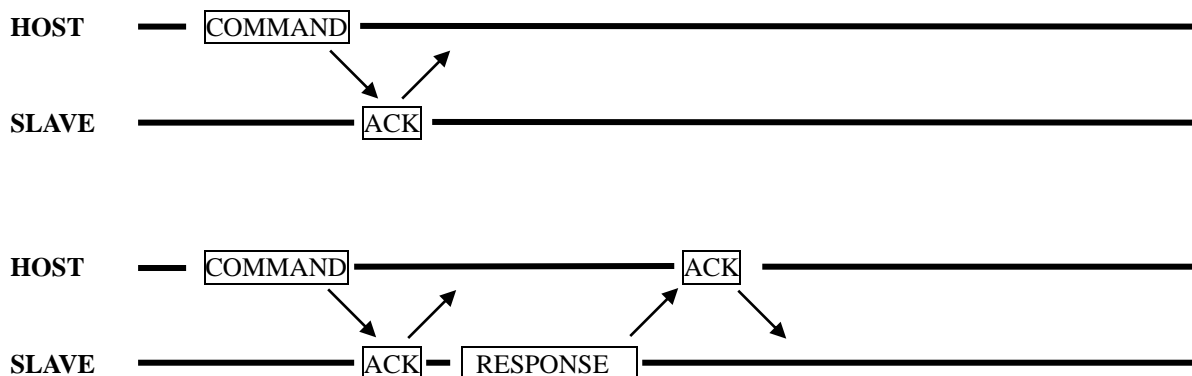

Doc No	KYX21XX SERIES SPECIFICATION	REV	PAGE	DATE
91000230-00		L	18 OF 23	2013. 06. 17.

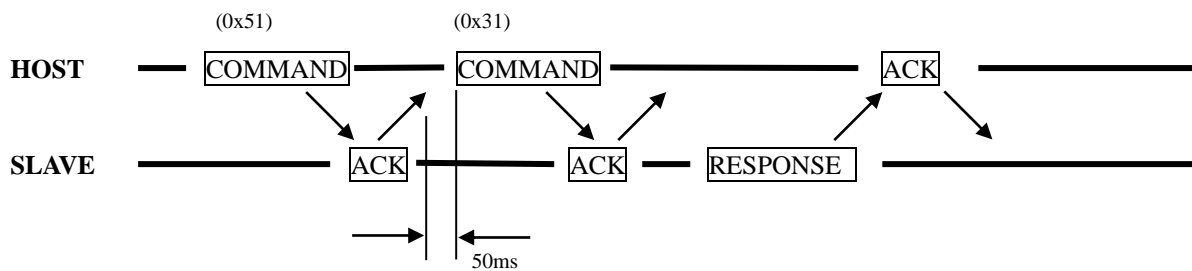
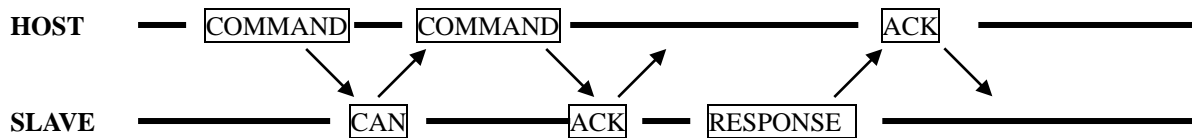
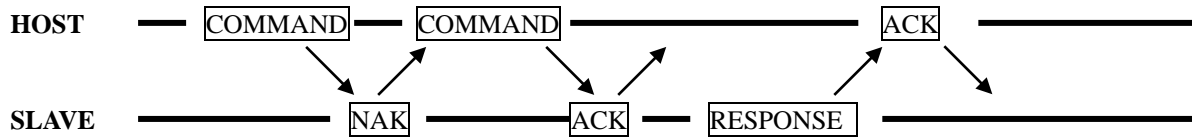
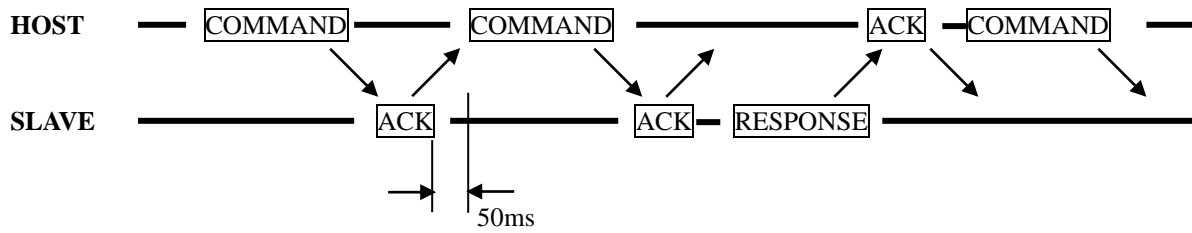

Cf.) To change Baud Rate, send command 50mS after receiving ACK.

6.4. Command Sets List

	Command	Description	Note
Clear	0x30	Error Clear	
Request	0x31	Status Request	
Issuing	0x40	Card Out	
Baud Rate Set	0x50	9600 BPS	
	0x51	19200 BPS	
Rom Version	0x60	Rom Version Check	
Issuing Length Set	0xF0	Card drop (Default)	Refer to Page 19
	0xF1		
	0xF2		
	0xF3		
	0xF4		

Doc No	KYX21XX SERIES SPECIFICATION	REV	PAGE	DATE
91000230-00		L	19 OF 23	2013. 06. 17.

6.5. Command Details

1. Clear, Card Length

: Initializing Parameters (Initializing Error Bit)

Command Packet

STX	Command	ETX	BCC
-----	---------	-----	-----

2. Status Request

: Host's Request for status of dispenser

Command Packet

STX	Command	ETX	BCC
-----	---------	-----	-----

Response Packet

STX	Status	ETX	BCC
-----	--------	-----	-----

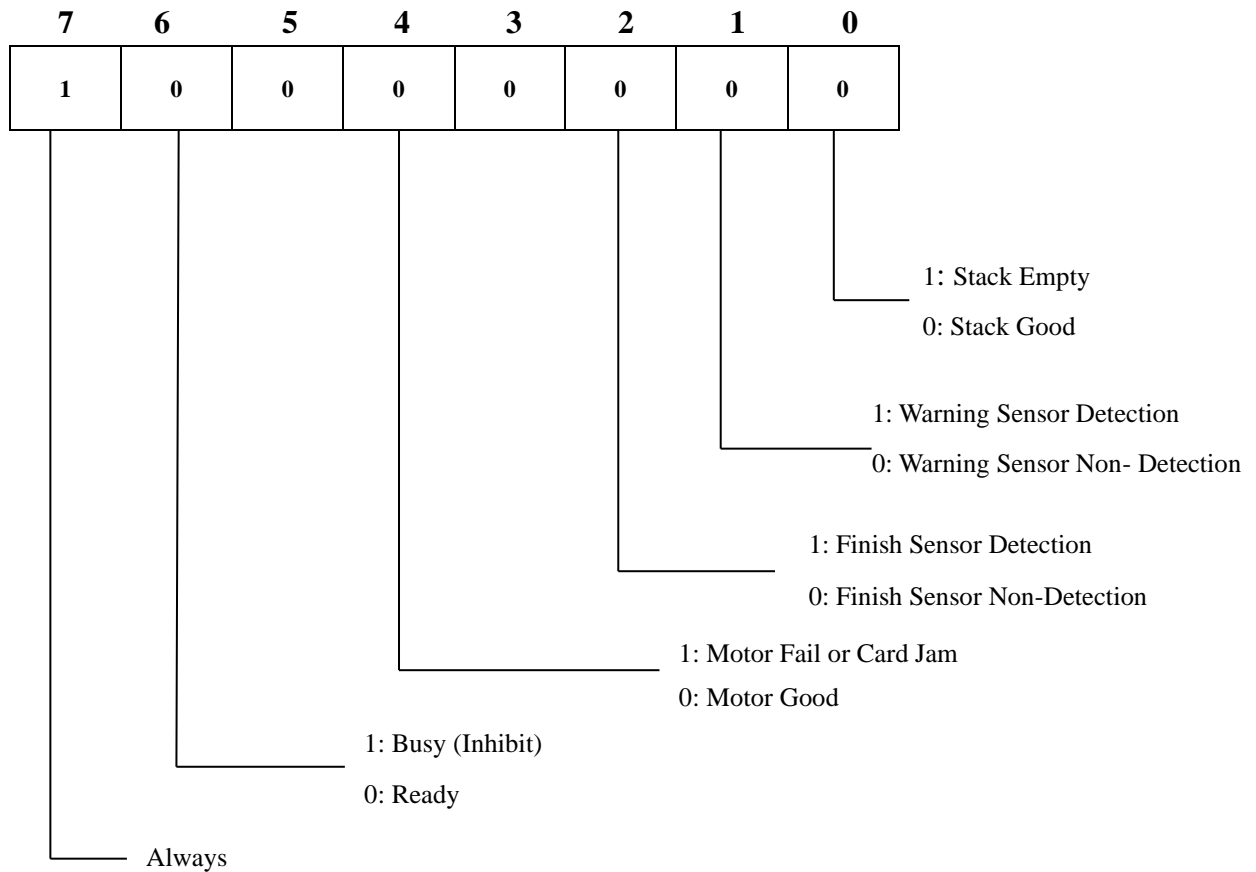

Stacker Status	Detail
'Stacker Good'	Good.
'Card Warning'	A few Card in the stacker
'Stacker Empty'	No cards in the stacker

Doc No	KYX21XX SERIES SPECIFICATION	REV	PAGE	DATE
91000230-00		L	20 OF 23	2013. 06. 17.

-Warning Sensor Setting



Set Value	20pcs	45pcs	70pcs
Set to 20pcs cards	ON	OFF	OFF
Set to 45pcs cards	OFF	ON	OFF
Set to 70pcs cards	OFF	OFF	ON

3. Issuing

: It starts to issue cards from Stacker

Command Packet

STX	Command	ETX	BCC
-----	---------	-----	-----

Ref) It takes 1.5 sec to 5 Sec to dispense a card.

4. VERSION: It indicates Firmware Version.

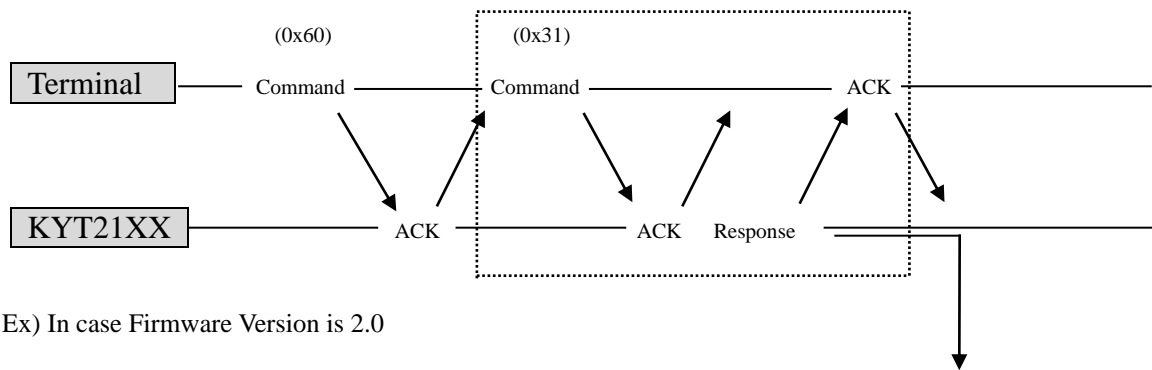

Ex) In case Firmware Version is 2.0

STX	0x20	ETX	BCC
-----	------	-----	-----

As Firmware version is not checked by sending Command (0x60), Status Command should be sent thereafter. Then, User gets Firmware version.

* Response to Status Request (0x31) following Command (0x60) is Firmware Versions, and Response to the next Status Request is about Dispenser.

Doc No	KYX21XX SERIES SPECIFICATION	REV	PAGE	DATE
91000230-00		L	21 OF 23	2013. 06. 17.

5. Card Issuing Length Set. Commands (Ref. 6.4 Commands Set List on Page 19)

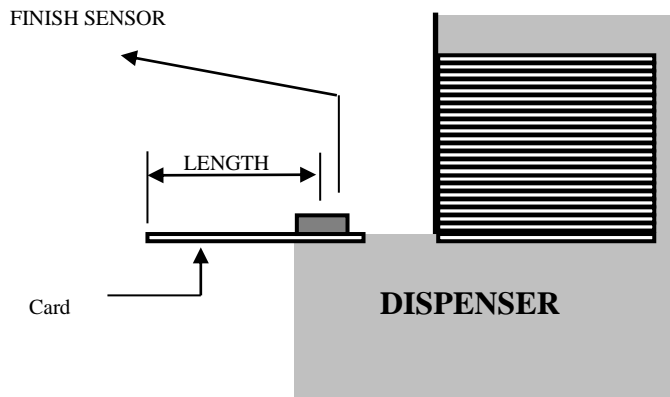

Commands to fix card length before dispensing a card.

- This is reserved as a fixed command and will be in operation until before power-off.
- If this command is not used, 0xF0 is set to be Default.
- To change this command while in operation, send a command after operation stops.
- This command is operable from 0xF0 to 0xF4.

- . 0xF0: Card Drop (Default).
- . 0xF1: When issued, a card stops 3 mm away from finish sensor
- . 0xF2: When issued, a card stops 18mm away from finish sensor (-5 mm, +1.5 mm)
- . 0xF3: When issued, a card stops 36mm away from finish sensor (-8 mm, +1.5 mm)
- . 0xF4: When issued, a card stops 54mm away from finish sensor (-10 mm, +1.5 mm)

Doc No	KYX21XX SERIES SPECIFICATION	REV	PAGE	DATE
91000230-00		L	22 OF 23	2013. 06. 17.

Example 1) RS232 Control Example

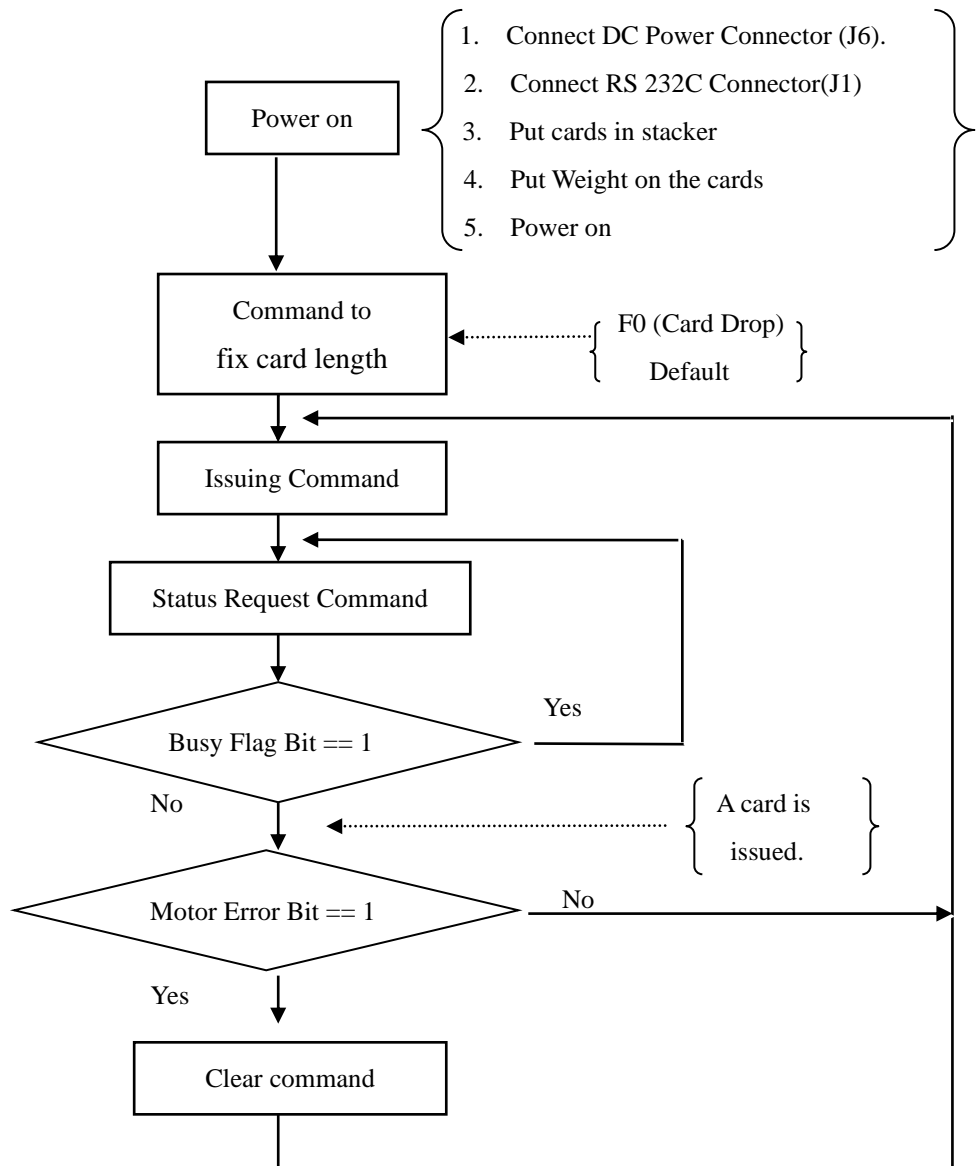

Doc No	KYX21XX SERIES SPECIFICATION	REV	PAGE	DATE
91000230-00		L	23 OF 23	2013. 06. 17.

Example 2) TTL Control Example

