



Ingeniería Electrónica
SMART IDENT

KYT-6000
MOTORIZED CARD READER/WRITER
Specifications

User Manual

KYT6000.UM.J.EN.doc

Doc No	KYT6XXX Series SPECIFICATION	REV	PAGE	DATE
91000050		J	3 OF 63	2017.03 .20.

MODEL NAME INFORMATION

KYX-6XXX SERIES MODEL

K Y T - 6 X X X X X

INTERFACE	FUNCTION	MS / IC	TRACK	OPTION	OPTION II	OPTION III
T: RS-232C E: Ethernet U: USB S: RS-422	6 : MOTORIZED TERMINAL UNIT MS/IC CARD READER	0 : - 1 : IC ONLY 2 : MS - READ ONLY 3 : MS - R/W 5 : MS(READ ONLY) + IC 6 : MS(R/W) + IC	0 : - 1 : ISO 1 TRK 2 : ISO 2 TRK 3 : ISO 3 TRK 4 : ISO 1,2 TRK 5 : ISO 1,3 TRK 6 : ISO 2,3 TRK 7 : ISO 1,2,3 TRK	0: - 1: LOW-CO 2: HI-CO 3: HI-CO&LOW-CO Selectable	A:External Power Including AC-DC adaptor B:External Power Without AC-DC adaptor C:RF + External Power Including AC-DC adaptor D:RF + External Power Without AC-DC adaptor E:Internal Power F:RF + Internal Power	0:- 1:Without LCD

NOTE: This equipment has been tested and found to comply with the limits for a Class A digital device, pursuant to part 15 of the FCC Rules. These limits are designed to provide reasonable protection against harmful interference when the equipment is operated in a commercial environment.

This equipment generates, uses, and can radiate radio frequency energy and, if not installed and used in accordance with the instruction manual, may cause harmful interference to radio communications. Operation of this equipment in a residential area is likely to cause harmful interference in which case the user will be required to correct the interference at his own expense.

CAUTION : Changes or modifications not expressly approved by the party responsible for compliance could void the user's authority to operate the equipment

Doc No	KYT6XXX Series SPECIFICATION	REV	PAGE	DATE
91000050		J	4 OF 63	2017.03 .20.

C O N T E N T S

1. Overview	5.
2. System Block Diagram	5.
3. Features	5.
4. Environment Requirements	6.
5. Specification	6.
6. Magnetic Card Process	7.
7. IC Card Process	8.
8. Interface Requirements	9.
9. Technical Drawing	11.
Interface	12.
Flow Chart	51.

Doc No	KYT6XXX Series SPECIFICATION	REV	PAGE	DATE
91000050		J	5 OF 63	2017.03 .20.

1. OVERVIEW

This specification is for the KYT-6XXX Series Motorized Magnetic and or IC Card Reader/Writer. In meeting customer's applications, intended data can be written and read through RS-232C communication.

This model has a function that is a reading writing a IC card confirming to ISO 7816 Part 1 – Part4(T=0, T=1) card.

KYT-6XXX Series has very compact and robust structure providing high reliability and long life.

KYT-6XXX series is suitable for Banking Terminals, Credit/Debit Card System, Auto ID and Access Control Application.

2. System Block Diagram

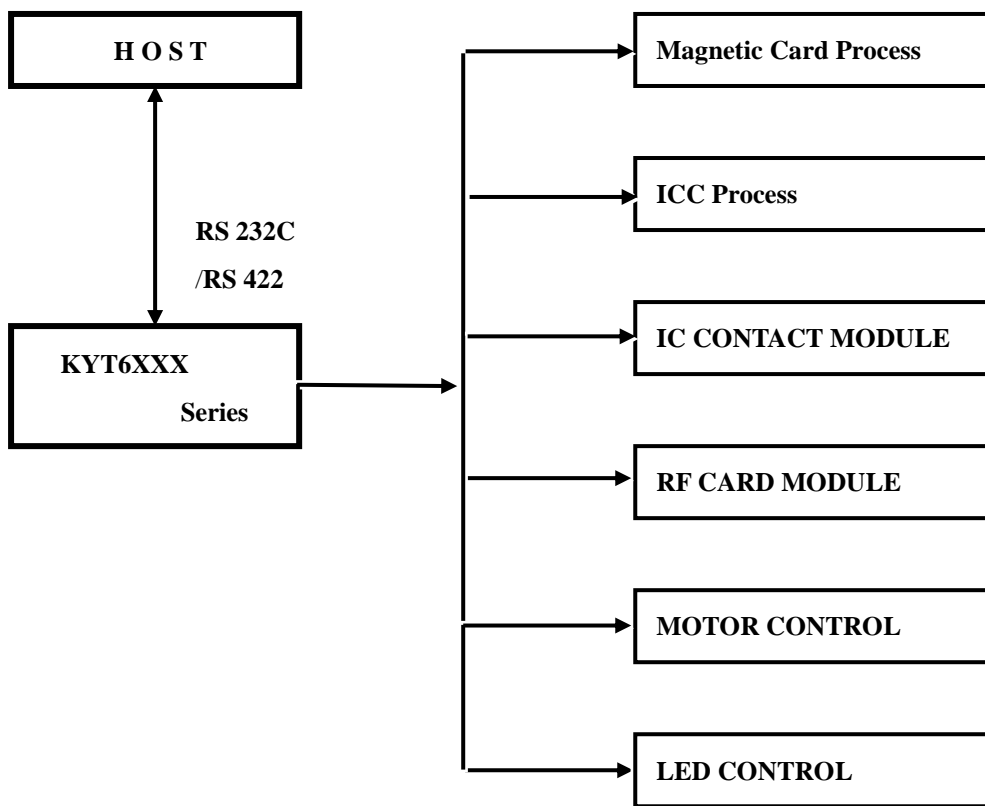

3. Features

- 3.1 Magnetic Stripe reading Triple tracks.
- 3.2 RS-232C interface with a HOST.
- 3.3 IC Card read and writers.
- 3.4 Support T=0 and T=1 protocol.

Doc No	KYT6XXX Series SPECIFICATION	REV	PAGE	DATE
91000050		J	6 OF 63	2017.03 .20.

4. Environmental Requirements

- 4.1 Operating Locus : in door use Only
- 4.2 Operating Temperature and Humidity : 5°C to 50°C(In 0°C to +5°C range, all specifications but 'Warped card' to be satisfied)
- 4.3 Conservation Temperature and humidity : 5% to 80% RH(No Codensa-tion)
- 4.4 Vibration : Amplitude 2mm, 10 to 50Hz X,Y,Z directions for 30min, 2G or less
- 4.5 Shock Resistance : Up to 30, 11msec

5. Specifications

- 5.1 Card Standard : ISO7811, ISO7816
- 5.2 Recording

	ISO Track 1	ISO Track 2	ISO Track 3
BPI	210	75	210
Capacity	Max 79	Max 40	Max 107
Reading Methods	F2F		
Length	Variable		
Card thickness	Plastic : 0.76 (+-) 0.08mm		

5.3 Power Consumption

5.3.1 Input voltage :

Internal Power:

- AC 100V/220V

External Power:

- DC +24V((+-) 5%) - 3A

- **PLUG:5.5X2.1MM** 

5.4 IC Contact Resistance : Less than 0.5Ω

5.5 IC Contact Force : 0.2N ~ 0.6N

5.6 Card Feeding Speed : 280mm/Sec((+-) 20%)

5.7 Weight : 3.6KG.

◆ Communication Environment

Asynchronous, Half duplex.

Baud Rate: 9600, 19200, 38400, 57600 BPS (Default : 19200 BPS)

Start Bit : 1Bit

Data Length : 8Bits

Parity : None

Stop Bit : 1Bit

Doc No	KYT6XXX Series SPECIFICATION	REV	PAGE	DATE
91000050		J	7 OF 63	2017.03 .20.

6. Magnetic Card Process

KYT6XXX Series is able encode data on all three tracks of ISO 1,2 and 3 in one Pass, which makes read/write process time shorter. It is a basic standard option to Read and Write to Low-co card. Optionally Hi-Co Card is read/Write.

◆ Power Consumption

Motor Starting or Reversing	:	Less than	250 mA
Card Feed & Reading	:	Less than	280 mA
Card Feed & Writing	:	Less than	450 mA
Steady state	:	Less than	80 mA

◆ Life and Reliability.

Life of Head : Approximately 1,000,000 passes
(1 pass is one forward or backware movement)

Error Rate : 3/1000 cycle.

- ◆ Warped Cards : This term refers to an evenly warped card having a height from the top of the convex surface to the base of the warped edge.



H : 3.00mm Max. for card jamming

Doc No	KYT6XXX Series SPECIFICATION	REV	PAGE	DATE
91000050		J	8 OF 63	2017.03 .20.

7. IC Card Process

KYT-6XXX accepts most of IC cards supporting ISO7816 T=0 and T=1.

◆ Number and Location of the contacts on IC Card

: Number and location of the contacts on IC Card is specified in ISO 7816-2 figure 2 Refer to Appendix A.

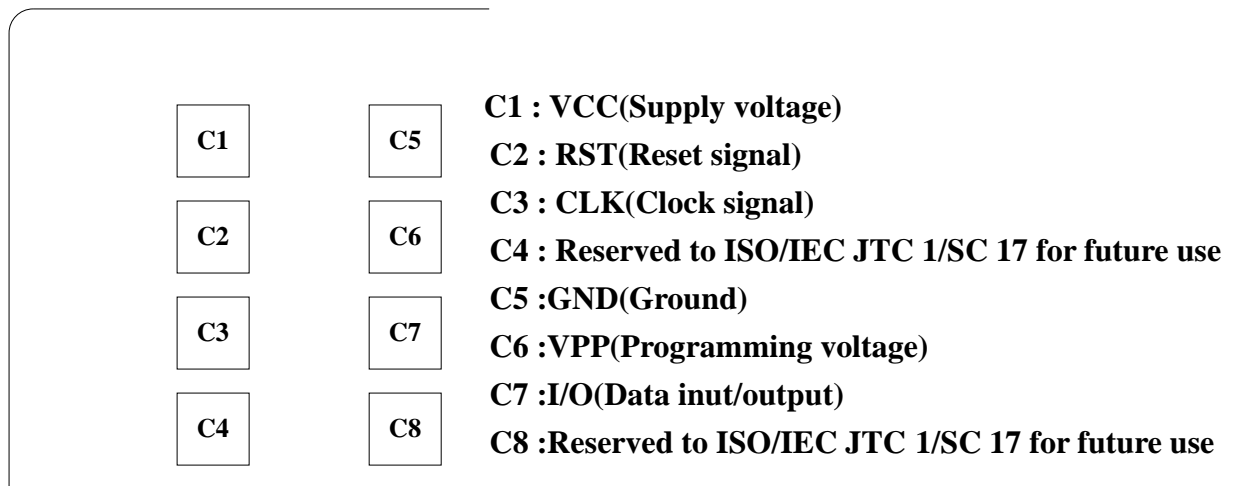

◆ Power Consumption

Motor Starting or Reversing : Less than 250mA
 Card Feed & Reading /Writing : Less than 500mA
 Steady state : Less than 80mA

◆Life and Reliability

IC Contact : Approximately 500,000 Passes.(Min)
 Error Rate : 3/1000 cycle.

8. Interface Requirement

Doc No	KYT6XXX Series SPECIFICATION	REV	PAGE	DATE
91000050		J	9 OF 63	2017.03 .20.

8.1RS-232C Interface

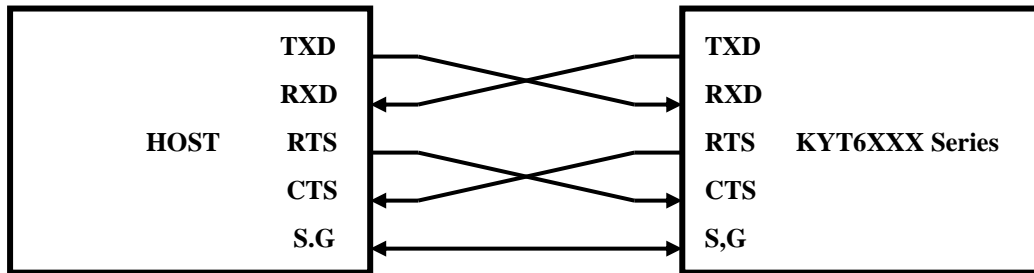

CASE 1) Part Number : RED-9S-LNA(HIROSE)

Location Number : P1

Pin No	INDEX	Remark
2	RXD	Receive
3	TXD	Transmit
7	RTS	Request to Send
8	CTS	Clear to Send
5	S.G	Signal Ground

CASE 2) Part Number : 53015-0510(MOLEX)

Location Number : CN1

Pin No	INDEX	Remark
1	RTS	Request to Send
2	RXD	Receive
3	TXD	Transmit
4	CTS	Clear to Send
5	GND	Signal Ground

8.2RS-422 Interface

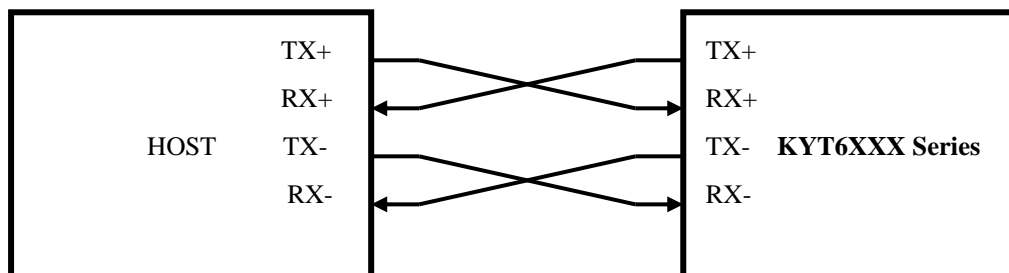

CASE 1) Part Number : D-SUB CONNECTOR(FEMALE)

Pin No	INDEX	Remark
1	TX+-	
4	RX+	
6	TX-	
8	RX-	

Doc No	KYT6XXX Series SPECIFICATION	REV	PAGE	DATE
91000050		J	10 OF 63	2017.03 .20.

8.3 USB Interface.

* Mini USB : B TYPE CONNECTOR 5PIN

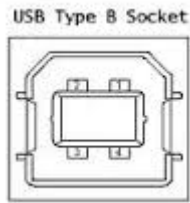

- Mini USB B & C TYPE CABLE (5PIN)



Doc No	KYT6XXX Series SPECIFICATION	REV	PAGE	DATE
91000050		J	11 OF 63	2017.03 .20.

9. Technical Drawing
- **Without RF**

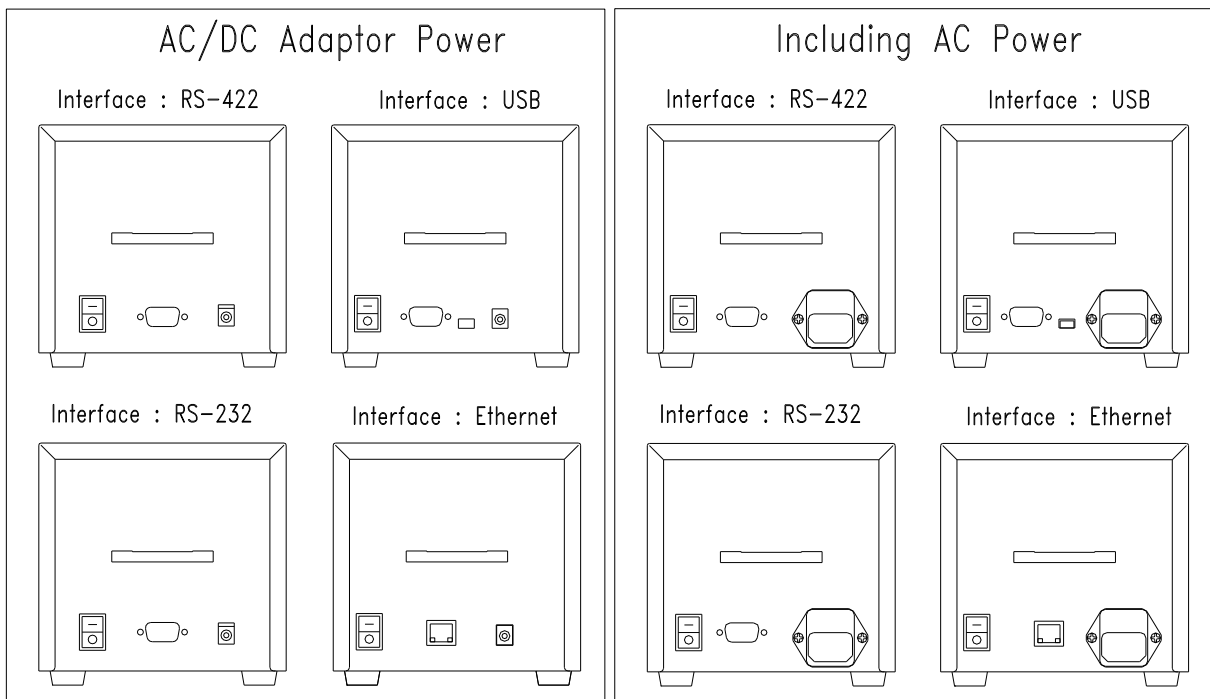
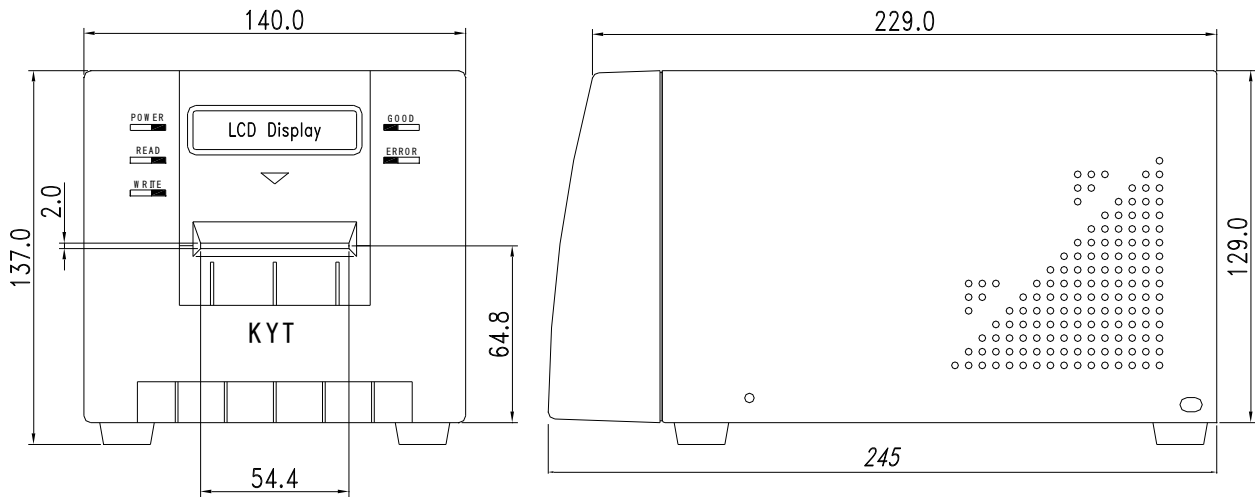

Power Adapter : **PLUG:5.5X2.1MM**

Doc No	KYT6XXX Series SPECIFICATION	REV	PAGE	DATE
91000050		J	12 OF 63	2017.03 .20.

-With RF

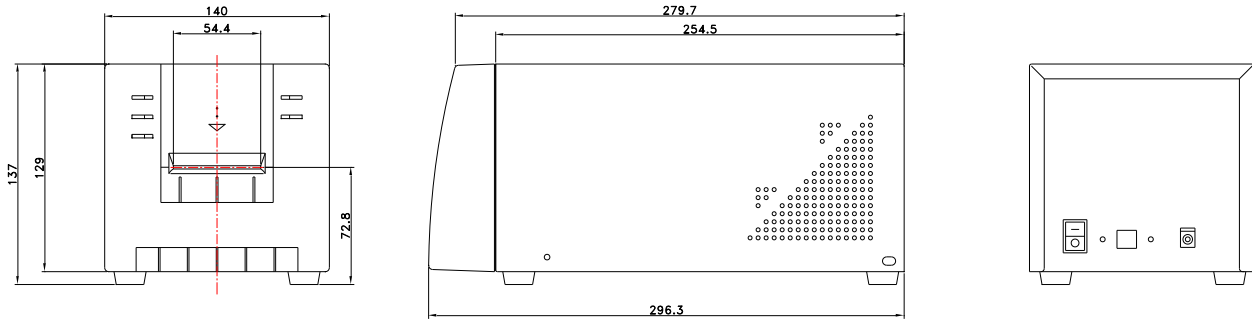

Doc No	KYT6XXX Series SPECIFICATION	REV	PAGE	DATE
91000050		J	13 OF 63	2017.03 .20.

Interface

Motorized Magnetic and IC Card and RF Card Reader/Writer

MODEL : KYT-6XXX

Doc No	KYT6XXX Series SPECIFICATION	REV	PAGE	DATE
91000050		J	14 OF 63	2017.03 .20.

1.Communication Method

- 1.1. Asynchronous, Half duplex.
- 1.2. Baud Rate : 9600, 19200 38400, 57600BPS(Default : 19200 BPS)
- 1.3. Start Bit : 1Bit
- 1.4. Data Length : 8Bits
- 1.5. Parity : None
- 1.6. Stop Bit : 1Bit

2.Control Characters

NANE	Hex Value	Description
SOH	01	Start of Header
STX	02	Start of Text
ETX	03	End of Text
EOT	04	End of Transmission
ENQ	05	Enquiry
ACK	06	Positive Acknowledge
NAK	15	Negative Acknowledge
CAN	18	Cancel

3. Frame Format

3.1. Command structure

SOH	Code	Cm	Pm	STX	DATA	ETX	BCC
-----	------	----	----	-----	------	-----	-----

Ref.) Command Sets List

3.2. Response structure

3.2.1. Positive Packet structure

SOH	Code	Cm	Pm	STX	'P'	STATUS	DATA	ETX	BCC
-----	------	----	----	-----	-----	--------	------	-----	-----

3..2.2. Negative Packet structure

SOH	Code	Cm	Pm	STX	'N'	ST1	ST2	ETX	BCC
-----BCC(XOR)-----									

Ref.) Negative Response Code List

Ex) Baud Rate Setting Command

SOH	Code	Cm	Pm	STX	DATA	ETX	BCC
[01]	[43]	[39]	[35]	[02]	[31]	[03]	[43]

BCC(0x43) = 0x43^0x31^0x30^0x02^0x31^0x03

Doc No	KYT6XXX Series SPECIFICATION	REV	PAGE	DATE
91000050		J	15 OF 63	2017.03 .20.

3.3.3 STATUS Structure Format

BIT 7	BIT 6	BIT 5	BIT 4	BIT 3	BIT 2	BIT 1	BIT 0
-------	-------	-------	-------	-------	-------	-------	-------

BIT	Description	REMARK
7	If Card Remained inside the unit (Yes: 1, No: 0)	
6	Approval to insert Card (Yes: 1, No: 0)	
5	X	0: Default
4	1 – RTS/CTS Setting Up 0 – RTS/CTS Removal	
3	X	
2	X	
1	X	
0	X	

4. Communication Protocol Sequence & Timing

(T : Time Setting Value(Refer to “C90”))

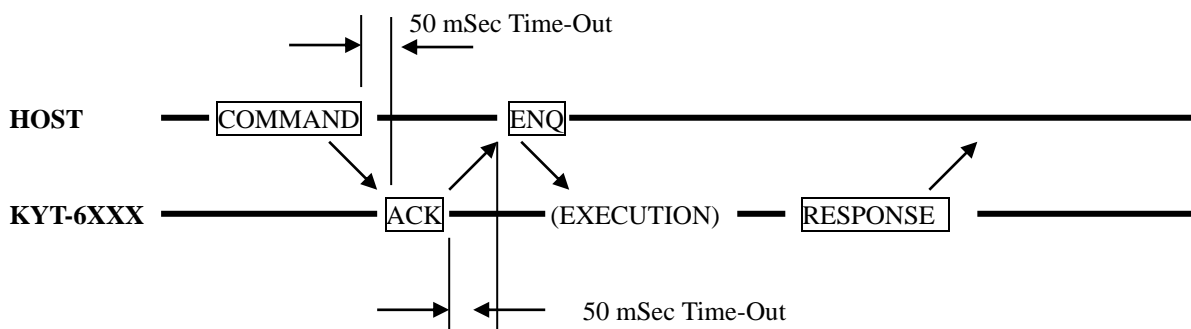
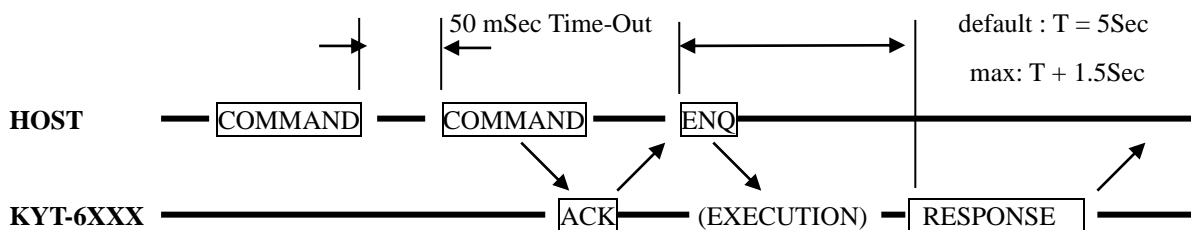
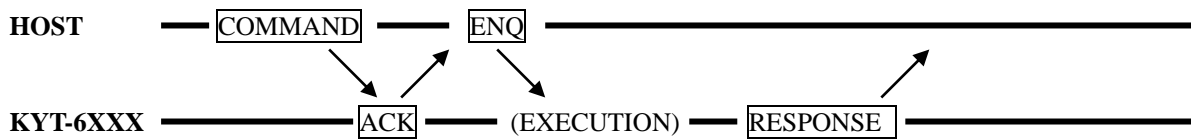

Doc No	KYT6XXX Series SPECIFICATION	REV	PAGE	DATE
91000050		J	16 OF 63	2017.03 .20.

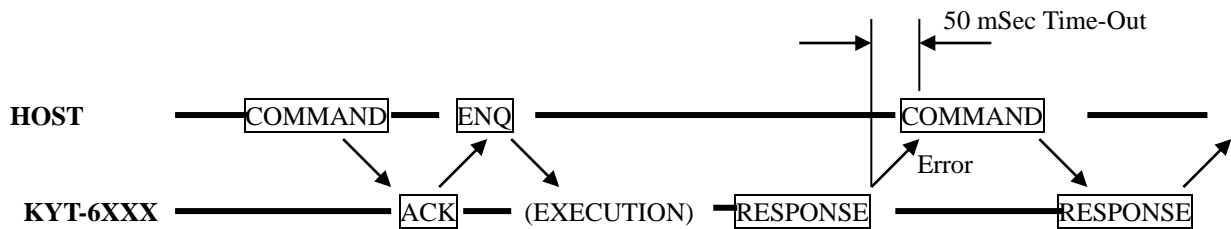
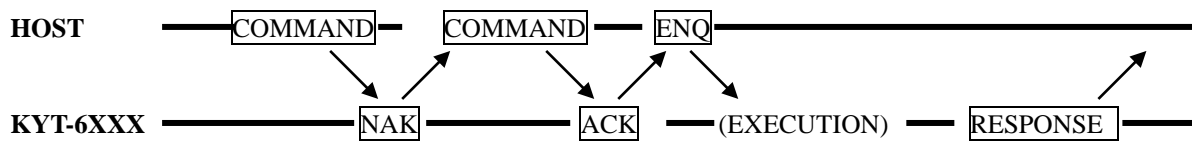
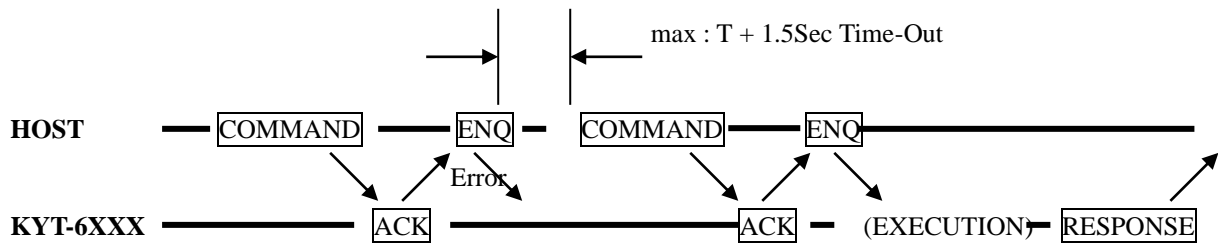

- Exception : If Card "STAND-BY" Time is designated as longer than 5 Sec., designate time + 5 Sec

Doc No	KYT6XXX Series SPECIFICATION	REV	PAGE	DATE
91000050		J	17 OF 63	2017.03 .20.

5. Command Sets List

	Code	Cm	Pm	Description	Note	
Initialize	43h	30h	30h	Initialize after forward direction Card discharge		
	43h	30h	31h	Initialize after reverse direction Card discharge		
	43h	30h	32h	Initialize after transfer to "STAND-BY" mode		
Request	43h	31h	30h	Read present Card location		
	43h	31h	31h	Read F/W Version of unit		
Card Control	43h	32h	30h	Approve to insert Card	Card Insertion Approval setting	
	43h	32h	31h	Prohibit to insert Card		
Moving	43h	33h	30h	Card Forward Direction Discharge		
	43h	33h	31h	Card Reverse Direction Discharge (Capture)		
	43h	33h	32h	Transfer to "STAND-BY" mode		
	43h	33h	33h	Card movement(FRONT ->REAR)		
	43h	33h	34h	Card ejection to the front		
	43h	33h	35h	Card Entry(M/S No Check)		
	43h	33h	36h	Card Entry After M/S Check		Pre_Head
	43h	33h	37h	Card Move to Rear with hold		
	43h	33h	41h	IC Card Accept & Contact		IC Control
M/S Read	43h	34h	30h	1 Track Data Reading		
	43h	34h	31h	2 Track Data Reading		
	43h	34h	32h	3 Track Data Reading		
	43h	34h	33h	1,2,3 All Track Data Reading		
	43h	34h	35h	1 Track Reading after Card Insertion STAND-BY		
	43h	34h	36h	2 Track Reading after Card Insertion STAND-BY		
	43h	34h	37h	3 Track Reading after Card Insertion STAND-BY		
	43h	34h	38h	1,2,3 All Track Reading after Card Insertion STAND-BY		
M/S Write	43h	35h	30h	1 Track Data Writing		
	43h	35h	31h	2 Track Data Writing		
	43h	35h	32h	3 Track Data Writing		
	43h	35h	35h	1 Track Writing after Card Insertion STAND-BY		
	43h	35h	36h	2 Track Writing after Card Insertion STAND-BY		
	43h	35h	37h	3 Track Writing after Card Insertion STAND-BY		
Binary M/S Read	42h	34h	30h	1 Track Data Reading	LOW DATA Read	
	42h	34h	31h	3 Track Data Reading		
	42h	34h	32h	2 Track Data Reading		
	42h	34h	35h	1 Track Reading after Card Insertion STAND-BY		
	42h	34h	36h	3 Track Reading after Card Insertion STAND-BY		
	42h	34h	37h	2 Track Reading after Card Insertion STAND-BY		
Binary M/S Write	42h	35h	30h	1 Track Data Writing	LOW DATA WRITE	
	42h	35h	31h	3 Track Data Writing		
	42h	35h	32h	2 Track Data Writing		
	42h	35h	35h	1 Track Writing after Card Insertion STAND-BY		
	42h	35h	36h	3 Track Writing after Card Insertion STAND-BY		
	42h	35h	37h	2 Track Writing after Card Insertion STAND-BY		

Doc No	KYT6XXX Series SPECIFICATION	REV	PAGE	DATE
91000050		J	18 OF 63	2017.03 .20.

IC Card Control	43h	36h	35h	IC Direct Control	IC Contact Option
	43h	36h	38h	IC Card Reset	
RF Card Control	52h	31h	30h	Identify the sector and block set at terminal.	
	52h	31h	31h	Identify whether if the antenna detect the card.	
	52h	31h	32h	Change the sector and block set at terminal.	
	52h	31h	33h	authentication key Read (KeyA or KeyB).	
	52h	31h	34h	Get the RF Card's serial.	
	52h	31h	35h	Select the authentication key: KeyA or KeyB.	
	52h	32h	30h	RF Card Data(balance or character) Read.	
	52h	32h	31h	RF Card Data (balance) Read.	
	52h	32h	32h	RF Card Data (balance) Write.	
	52h	32h	33h	RF Card Data (balance or character) Write.	
	52h	32h	34h	Increment the balance of card to the specified amount.	
	52h	32h	35h	Decrement the balance of card to the specified amount..	
	52h	32h	41h	RF Card Data(balance or character) Read.	
	52h	32h	42h	RF Card Data (balance) Read.	
	52h	32h	43h	RF Card Data (balance) Write.	
	52h	32h	44h	RF Card Data (balance or character) Write.	
	52h	32h	45h	Increment the balance of card to the specified amount.	
	52h	32h	46h	Decrement the balance of card to the specified amount..	
	52h	33h	30h	RF Card Key Change(Access Condition Data Exclude).	
	52h	33h	31h	RF Card Key Change(Access Condition Data inclusion).	
52h	33h	32h	Module Key Change.		
52h	34h	30h	Power On (The carrier wave emitted in antenna.)		
52h	34h	31h	Power Off(The carrier wave not emitted in antenna.)		
Retry Set	43h	37h	30h	Retry 0	
	43h	37h	31h	Retry 1	
	43h	37h	32h	Retry 2	
	43h	37h	33h	Retry 3	
	43h	37h	34h	Retry 4	
Cleaning	43h	38h	30h	Head Cleaning	
Buzzer Control	43h	38h	31h	Good Buzzer On	
	43h	38h	32h	Error Buzzer On	
Setting	43h	39h	30h	Card Wait Time Set	
	43h	39h	31h	Series(RTS,CTS) Setting	
	43h	39h	32h	Series(RTS,CTS) Cancellation	
	43h	39h	33h	Baud Rate Setting	
Hi-Lo Set	43h	39h	41h	High-Co and Low-Co Select	
LED Control	43h	39h	42h	Led On/Off Control	
Select MS BPI	43h	39h	43h	MS Track 2 BPI Select	

Doc No	KYT6XXX Series SPECIFICATION	REV	PAGE	DATE
91000050		J	19 OF 63	2017.03 .20.

Mifare Plus	45h	30h	31h	Change the data and AES Keys.	
	45h	30h	32h	Finalize the personalization and switch up.	
	45h	30h	33h	Switch up to higher security levels.	
	45h	30h	34h	Authentication of the Security level1.	
	45h	30h	35h	Authentication of the Security level2.	
	45h	31h	30h	First Authentication of the Security level3.	
	45h	31h	31h	Follow Authentication of the Security level3.	
	45h	31h	33h	Read the data and the VALUE data.	
	45h	31h	34h	Write the data and the VALUE data.	
	45h	31h	35h	Increment the VALUE data.	
	45h	31h	36h	Decrement the VALUE data.	
	45h	31h	37h	Stores the content to the specified address.	
	45h	31h	38h	Copies the content found in the Value block.	
	45h	32h	30h	Carry out by measuring the round trip time.	

6. Negative Response Code List

NO	ST1	ST2	Description	NOTE
1	'0'	'1'	Command Not Define	
2	'0'	'2'	No Card	
3	'0'	'3'	Fail Card	
4	'0'	'4'	Card JAM Error	
5	'0'	'5'	Data Fail	
6	'0'	'6'	Time Out	
7	'0'	'7'	Write Error	
8	'0'	'8'	Blank Error	
9	'0'	'9'	Pre_Amble Error	
10	'1'	'0'	Parity Error	
11	'1'	'1'	Post_Amble Error	
12	'1'	'2'	LRC Error	
13	'1'	'4'	IC Card Contact Error	
14	'1'	'5'	IC Card Control Error	
15	'1'	'6'	IC Read Error	
16	'1'	'7'	IC Write Error	
17	'1'	'8'	Not Define	
18	'1'	'9'	RF POWER On Error	
19	'2'	'0'	RF Card Authentic Error	
20	'2'	'1'	RF Card Select Error	
21	'2'	'2'	RF Card Anticllsion Error	
22	'2'	'3'	RF Card Read Error	
23	'2'	'4'	RF Card Write Error	
24	'2'	'5'	RF Card Inc Error	
25	'2'	'6'	RF Card Dec Error	
26	'2'	'7'	RF Card Value Error	
27	'2'	'8'	Sector or Block Error	
28	'2'	'9'	RC500 Init Error	

Doc No	KYT6XXX Series SPECIFICATION	REV	PAGE	DATE
91000050		J	20 OF 63	2017.03 .20.

7. Command Detail

7.1 Initialize

7.1.1 "C00" : If Card Remained inside the unit, Initialize after forward direction

Card discharge

Command Packet

SOH	'C'	'0'	'0'	STX	ETX	BCC
-----	-----	-----	-----	-----	-----	-----

Positive Response Packet

SOH	'C'	'0'	'0'	STX	'P'	STATUS	ETX	BCC
-----	-----	-----	-----	-----	-----	--------	-----	-----

Negative Response Packet

SOH	'C'	'0'	'0'	STX	'N'	ST1	ST2	ETX	BCC
-----	-----	-----	-----	-----	-----	-----	-----	-----	-----

7.1.2 "C01" : If Card Remained inside the unit, initialize after reverse direction

Card discharge (Capture)

Command Packet

SOH	'C'	'0'	'1'	STX	ETX	BCC
-----	-----	-----	-----	-----	-----	-----

Positive Response Packet

SOH	'C'	'0'	'1'	STX	'P'	STATUS	ETX	BCC
-----	-----	-----	-----	-----	-----	--------	-----	-----

Negative Response Packet

SOH	'C'	'0'	'1'	STX	'N'	ST1	ST2	ETX	BCC
-----	-----	-----	-----	-----	-----	-----	-----	-----	-----

7.1.3 "C02" : If Card Remained inside the unit , Initialize after transfer to

"STAND-BY" mode

Command Packet

SOH	'C'	'0'	'2'	STX	ETX	BCC
-----	-----	-----	-----	-----	-----	-----

Positive Response Packet

SOH	'C'	'0'	'2'	STX	'P'	STATUS	ETX	BCC
-----	-----	-----	-----	-----	-----	--------	-----	-----

Negative Response Packet

SOH	'C'	'0'	'2'	STX	'N'	ST1	ST2	ETX	BCC
-----	-----	-----	-----	-----	-----	-----	-----	-----	-----

7.2 Request

7.2.1 "C10" : Read exact Card location

Command Packet

SOH	'C'	'1'	'0'	STX	ETX	BCC
-----	-----	-----	-----	-----	-----	-----

Positive Response Packet

SOH	'C'	'1'	'0'	STX	'P'	STATUS	DATA	ETX	BCC
-----	-----	-----	-----	-----	-----	--------	------	-----	-----

DATA Structure

X	X	X	X	BIT 3	BIT 2	BIT 1	BIT 0
---	---	---	---	-------	-------	-------	-------

3 BIT : PH 4 2 BIT : PH 3 1 BIT : PH 2 0 BIT : PH 1

Doc No	KYT6XXX Series SPECIFICATION	REV	PAGE	DATE
91000050		J	21 OF 63	2017.03 .20.

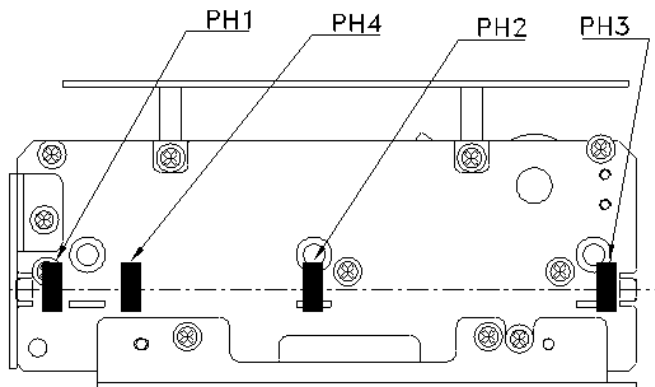

Negative Response Packet

SOH	'C'	'1'	'0'	STX	'N'	ST1	ST2	ETX	BCC
-----	-----	-----	-----	-----	-----	-----	-----	-----	-----

7.2.1 "C11" : F/W Version Read

Command Packet

SOH	'C'	'1'	'1'	STX	ETX	BCC
-----	-----	-----	-----	-----	-----	-----

Positive Response Packet

SOH	'C'	'1'	'1'	STX	'P'	STATUS	DATA	ETX	BCC
-----	-----	-----	-----	-----	-----	--------	------	-----	-----

DATA Structure

'V'	X1	'.'	X2	X3
-----	----	-----	----	----

Ex) "V1.00"

Negative Response Packet

SOH	'C'	'1'	'1'	STX	'N'	ST1	ST2	ETX	BCC
-----	-----	-----	-----	-----	-----	-----	-----	-----	-----

7.3 Card Control

7.3.1 "C20" : Approval Card Insertion into the unit.

When this command is sent to card reader , card reader takes a card into its body after the card is detected by sensors. And all following processes are executed according to commands .

Command Packet

SOH	'C'	'2'	'0'	STX	ETX	BCC
-----	-----	-----	-----	-----	-----	-----

Positive Response Packet

SOH	'C'	'2'	'0'	STX	'P'	STATUS	ETX	BCC
-----	-----	-----	-----	-----	-----	--------	-----	-----

Negative Response Packet

SOH	'C'	'2'	'0'	STX	'N'	ST1	ST2	ETX	BCC
-----	-----	-----	-----	-----	-----	-----	-----	-----	-----

Doc No	KYT6XXX Series SPECIFICATION	REV	PAGE	DATE
91000050		J	22 OF 63	2017.03 .20.

7.3.2 “C21” : Prohibit Card Insertion into the unit

This is a command to disable above command “C20” .

Command Packet

SOH	‘C’	‘2’	‘1’	STX	ETX	BCC
-----	-----	-----	-----	-----	-----	-----

Positive Response Packet

SOH	‘C’	‘2’	‘1’	STX	‘P’	STATUS	ETX	BCC
-----	-----	-----	-----	-----	-----	--------	-----	-----

Negative Response Packet

SOH	‘C’	‘2’	‘1’	STX	‘N’	ST1	ST2	ETX	BCC
-----	-----	-----	-----	-----	-----	-----	-----	-----	-----

7.4 Card Moving

7.4.1 “C30” : If Card Remained inside the unit, forward direction Card

Discharge(EJECT)

Command Packet

SOH	‘C’	‘3’	‘0’	STX	ETX	BCC
-----	-----	-----	-----	-----	-----	-----

Positive Response Packet

SOH	‘C’	‘3’	‘0’	STX	‘P’	STATUS	ETX	BCC
-----	-----	-----	-----	-----	-----	--------	-----	-----

Negative Response Packet

SOH	‘C’	‘3’	‘0’	STX	‘N’	ST1	ST2	ETX	BCC
-----	-----	-----	-----	-----	-----	-----	-----	-----	-----

7.4.2 “C31” : If Card Remained inside the unit, reverse direction Card

Discharge(CAPTURE)

Command Packet

SOH	‘C’	‘3’	‘1’	STX	ETX	BCC
-----	-----	-----	-----	-----	-----	-----

Positive Response Packet

SOH	‘C’	‘3’	‘1’	STX	‘P’	STATUS	ETX	BCC
-----	-----	-----	-----	-----	-----	--------	-----	-----

Negative Response Packet

SOH	‘C’	‘3’	‘1’	STX	‘N’	ST1	ST2	ETX	BCC
-----	-----	-----	-----	-----	-----	-----	-----	-----	-----

7.4.3 “C32” : If Card Remained inside the unit, transfer to “READ STAND-

BY” mode

Command Packet

SOH	‘C’	‘3’	‘2’	STX	ETX	BCC
-----	-----	-----	-----	-----	-----	-----

Positive Response Packet

SOH	‘C’	‘3’	‘2’	STX	‘P’	STATUS	ETX	BCC
-----	-----	-----	-----	-----	-----	--------	-----	-----

Negative Response Packet

SOH	‘C’	‘3’	‘2’	STX	‘N’	ST1	ST2	ETX	BCC
-----	-----	-----	-----	-----	-----	-----	-----	-----	-----

Doc No	KYT6XXX Series SPECIFICATION	REV	PAGE	DATE
91000050		J	23 OF 63	2017.03 .20.

7.4.4 “C33” : If Card Remained inside the unit, transfer to “WRITE STAND-BY” mode (Function “C32” identical)

Command Packet

SOH	‘C’	‘3’	‘3’	STX	ETX	BCC
-----	-----	-----	-----	-----	-----	-----

Positive Response Packet

SOH	‘C’	‘3’	‘3’	STX	‘P’	STATUS	ETX	BCC
-----	-----	-----	-----	-----	-----	--------	-----	-----

Negative Response Packet

SOH	‘C’	‘3’	‘3’	STX	‘N’	ST1	ST2	ETX	BCC
-----	-----	-----	-----	-----	-----	-----	-----	-----	-----

7.4.5 “C34” : Card ejection to the front if card is inside MSRW.

Command Packet

SOH	‘C’	‘3’	‘4’	STX	ETX	BCC
-----	-----	-----	-----	-----	-----	-----

Positive Response Packet

SOH	‘C’	‘3’	‘4’	STX	‘P’	STATUS	ETX	BCC
-----	-----	-----	-----	-----	-----	--------	-----	-----

Negative Response Packet

SOH	‘C’	‘3’	‘4’	STX	‘N’	ST1	ST2	ETX	BCC
-----	-----	-----	-----	-----	-----	-----	-----	-----	-----

7.4.6 “C35” : After receiving this command, Card Reader stands by for insertion of a card for defined time duration. After checking the insertion of a card, Card Reader takes in the card.

Command Packet

SOH	‘C’	‘3’	‘5’	STX	ETX	BCC
-----	-----	-----	-----	-----	-----	-----

Positive Response Packet

SOH	‘C’	‘3’	‘5’	STX	‘P’	STATUS	ETX	BCC
-----	-----	-----	-----	-----	-----	--------	-----	-----

Negative Response Packet

SOH	‘C’	‘3’	‘5’	STX	‘N’	ST1	ST2	ETX	BCC
-----	-----	-----	-----	-----	-----	-----	-----	-----	-----

7.4.7 “C36” : After receiving this command, Card Reader stands by for insertion of a card defined time duration. Realizing the card insertion, Card Reader takes in the card after checking if data (i.e, bits) is written on magnetic stripe(Pre_Head setting)

Command Packet

SOH	‘C’	‘3’	‘6’	STX	ETX	BCC
-----	-----	-----	-----	-----	-----	-----

Positive Response Packet

SOH	‘C’	‘3’	‘6’	STX	‘P’	STATUS	ETX	BCC
-----	-----	-----	-----	-----	-----	--------	-----	-----

Negative Response Packet

SOH	‘C’	‘3’	‘6’	STX	‘N’	ST1	ST2	ETX	BCC
-----	-----	-----	-----	-----	-----	-----	-----	-----	-----

Doc No	KYT6XXX Series SPECIFICATION	REV	PAGE	DATE
91000050		J	24 OF 63	2017.03 .20.

7.4.8 “C37” : Card ejection to the rear(Hold) if card is inside MSR.W.

Command Packet

SOH	‘C’	‘3’	‘7’	STX	ETX	BCC
-----	-----	-----	-----	-----	-----	-----

Positive Response Packet

SOH	‘C’	‘3’	‘7’	STX	‘P’	STATUS	ETX	BCC
-----	-----	-----	-----	-----	-----	--------	-----	-----

Negative Response Packet

SOH	‘C’	‘3’	‘7’	STX	‘N’	ST1	ST2	ETX	BCC
-----	-----	-----	-----	-----	-----	-----	-----	-----	-----

7.4.8 “C3A” : Card Reader considers the checked card IC card if Card Reader

receives this command After making contact with IC card ,Card Reader stands by for IC card control command.

Command Packet

SOH	‘C’	‘3’	‘A’	STX	ETX	BCC
-----	-----	-----	-----	-----	-----	-----

Positive Response Packet

SOH	‘C’	‘3’	‘A’	STX	‘P’	STATUS	ETX	BCC
-----	-----	-----	-----	-----	-----	--------	-----	-----

Negative Response Packet

SOH	‘C’	‘3’	‘A’	STX	‘N’	ST1	ST2	ETX	BCC
-----	-----	-----	-----	-----	-----	-----	-----	-----	-----

7.5 Magnetic Data Read

7.5.1 “C40” : If Card Remained inside the unit , Track Data Read

Command Packet

SOH	‘C’	‘4’	‘0’	STX	ETX	BCC
-----	-----	-----	-----	-----	-----	-----

Positive Response Packet

SOH	‘C’	‘4’	‘0’	STX	‘P’	STATUS	DATA	ETX	BCC
-----	-----	-----	-----	-----	-----	--------	------	-----	-----

DATA : 1 – 76 Byte ASCII String

Negative Response Packet

SOH	‘C’	‘4’	‘0’	STX	‘N’	ST1	ST2	ETX	BCC
-----	-----	-----	-----	-----	-----	-----	-----	-----	-----

7.5.2 “C41” : If Card Remained inside the unit, 2 Track Data Read

Command Packet

SOH	‘C’	‘4’	‘1’	STX	ETX	BCC
-----	-----	-----	-----	-----	-----	-----

Positive Response Packet

SOH	‘C’	‘4’	‘1’	STX	‘P’	STATUS	DATA	ETX	BCC
-----	-----	-----	-----	-----	-----	--------	------	-----	-----

DATA : 1 – 37 Byte ASCII String

Negative Response Packet

SOH	‘C’	‘4’	‘1’	STX	‘N’	ST1	ST2	ETX	BCC
-----	-----	-----	-----	-----	-----	-----	-----	-----	-----

Doc No	KYT6XXX Series SPECIFICATION	REV	PAGE	DATE
91000050		J	25 OF 63	2017.03 .20.

7.5.3 “C42” : If Card Remained inside the unit, 3 Track Data Read

Command Packet

SOH	'C'	'4'	'2'	STX	ETX	BCC
-----	-----	-----	-----	-----	-----	-----

Positive Response Packet

SOH	'C'	'4'	'2'	STX	'P'	STATUS	DATA	ETX	BCC
-----	-----	-----	-----	-----	-----	--------	------	-----	-----

DATA : 1 – 104 Byte ISCII String

Negative Response Packet

SOH	'C'	'4'	'2'	STX	'N'	ST1	ST2	ETX	BCC
-----	-----	-----	-----	-----	-----	-----	-----	-----	-----

7.5.4 “C43” : If Card Remained inside the unit, ALL Track(1, 2, 3 Track) Data

Read

Command Packet

SOH	'C'	'4'	'3'	STX	ETX	BCC
-----	-----	-----	-----	-----	-----	-----

Positive Response Packet

SOH	'C'	'4'	'3'	STX	'P'	STATUS	DATA	ETX	BCC
-----	-----	-----	-----	-----	-----	--------	------	-----	-----

DATA Structure

1 Track Data	00h	2 Track Data	00h	3 Track Data
--------------	-----	--------------	-----	--------------

Return Negative Code in case of Read Error

(Ref. : Negative Response Code List)

Negative Response Packet

SOH	'C'	'4'	'3'	STX	'N'	ST1	ST2	ETX	BCC
-----	-----	-----	-----	-----	-----	-----	-----	-----	-----

7.5.5 “C45” : If No Card Remained inside the unit, STAND-BY for specified

time and Read 1 TRACK Data if Card is inserted.

Command Packet

SOH	'C'	'4'	'5'	STX	ETX	BCC
-----	-----	-----	-----	-----	-----	-----

Positive Response Packet

SOH	'C'	'4'	'5'	STX	'P'	STATUS	DATA	ETX	BCC
-----	-----	-----	-----	-----	-----	--------	------	-----	-----

DATA : 1 – 76 Byte ASCII String

Negative Response Packet

SOH	'C'	'4'	'5'	STX	'N'	ST1	ST2	ETX	BCC
-----	-----	-----	-----	-----	-----	-----	-----	-----	-----

7.5.6 “C46” : If No Card Remained inside the unit, STAND-BY for specified

time and Read 2 TRACK Data if Card is inserted.

Command Packet

SOH	'C'	'4'	'6'	STX	ETX	BCC
-----	-----	-----	-----	-----	-----	-----

Positive Response Packet

SOH	'C'	'4'	'6'	STX	'P'	STATUS	DATA	ETX	BCC
-----	-----	-----	-----	-----	-----	--------	------	-----	-----

DATA : 1 – 37 Byte ASCII String

Negative Response Packet

SOH	'C'	'4'	'6'	STX	'N'	ST1	ST2	ETX	BCC
-----	-----	-----	-----	-----	-----	-----	-----	-----	-----

Doc No	KYT6XXX Series SPECIFICATION	REV	PAGE	DATE
91000050		J	26 OF 63	2017.03 .20.

7.5.7 “C47” : If No Card Remained inside the unit, STAND-BY for specified time and Read 3 TRACK Data if Card is inserted.

Command Packet

SOH	‘C’	‘4’	‘7’	STX	ETX	BCC
-----	-----	-----	-----	-----	-----	-----

Positive Response Packet

SOH	‘C’	‘4’	‘7’	STX	‘P’	STATUS	DATA	ETX	BCC
-----	-----	-----	-----	-----	-----	--------	------	-----	-----

DATA : 1 – 104 Byte ASCII String

Negative Response Packet

SOH	‘C’	‘4’	‘7’	STX	‘N’	ST1	ST2	ETX	BCC
-----	-----	-----	-----	-----	-----	-----	-----	-----	-----

7.5.8 “C48” : If No Card Remained inside the unit, STAND-BY for specified time and Read all TRACK Data if Card is inserted.

Command Packet

SOH	‘C’	‘4’	‘8’	STX	ETX	BCC
-----	-----	-----	-----	-----	-----	-----

Positive Response Packet

SOH	‘C’	‘4’	‘8’	STX	‘P’	STATUS	DATA	ETX	BCC
-----	-----	-----	-----	-----	-----	--------	------	-----	-----

DATA Structure

1 Track Data	00h	2 Track Data	00h	3 Track Data
--------------	-----	--------------	-----	--------------

Return Negative Code in case of Read Error

(Ref. : Negative Response Code List)

Negative Response Packet

SOH	‘C’	‘4’	‘8’	STX	‘N’	ST1	ST2	ETX	BCC
-----	-----	-----	-----	-----	-----	-----	-----	-----	-----

7.6 Magnetic Data Write

7.6.1 “C50” : If Card Remained inside the unit, 1 Track Data Write

Command Packet

SOH	‘C’	‘5’	‘0’	STX	DATA	ETX	BCC
-----	-----	-----	-----	-----	------	-----	-----

DATA : 1 – 76 Byte ASCII(ALPHA_NEMERIC) String

Positive Response Packet

SOH	‘C’	‘5’	‘0’	STX	‘P’	STATUS	ETX	BCC
-----	-----	-----	-----	-----	-----	--------	-----	-----

Negative Response Packet

SOH	‘C’	‘5’	‘0’	STX	‘N’	ST1	ST2	ETX	BCC
-----	-----	-----	-----	-----	-----	-----	-----	-----	-----

Doc No	KYT6XXX Series SPECIFICATION	REV	PAGE	DATE
91000050		J	27 OF 63	2017.03 .20.

7.6.2 “C51” : If Card Remained inside the unit, 2 Track Data Write

Command Packet

SOH	‘C’	‘5’	‘1’	STX	DATA	ETX	BCC
-----	-----	-----	-----	-----	------	-----	-----

DATA : 1 – 37 Byte ASCII(NUMERIC Only) String

Positive Response Packet

SOH	‘C’	‘5’	‘1’	STX	‘P’	STATUS	ETX	BCC
-----	-----	-----	-----	-----	-----	--------	-----	-----

Negative Response Packet

SOH	‘C’	‘5’	‘1’	STX	‘N’	ST1	ST2	ETX	BCC
-----	-----	-----	-----	-----	-----	-----	-----	-----	-----

7.6.3 “C52” : If Card Remained inside the unit, 3 Track Data Write

Command Packet

SOH	‘C’	‘5’	‘2’	STX	DATA	ETX	BCC
-----	-----	-----	-----	-----	------	-----	-----

DATA : 1 – 104 Byte ASCII(NUMERIC) String

Positive Response Packet

SOH	‘C’	‘5’	‘2’	STX	‘P’	STATUS	ETX	BCC
-----	-----	-----	-----	-----	-----	--------	-----	-----

Negative Response Packet

SOH	‘C’	‘5’	‘2’	STX	‘N’	ST1	ST2	ETX	BCC
-----	-----	-----	-----	-----	-----	-----	-----	-----	-----

7.6.5 “C55” : If No Card Remained inside the unit, STAND-BY for specified time and Write 1 TRACK Data if Card is inserted.

Command Packet

SOH	‘C’	‘5’	‘5’	STX	DATA	ETX	BCC
-----	-----	-----	-----	-----	------	-----	-----

DATA : 1 – 76 Byte ASCII(ALPHA_NEMERIC) String

Positive Response Packet

SOH	‘C’	‘5’	‘5’	STX	‘P’	STATUS	ETX	BCC
-----	-----	-----	-----	-----	-----	--------	-----	-----

Negative Response Packet

SOH	‘C’	‘5’	‘5’	STX	‘N’	ST1	ST2	ETX	BCC
-----	-----	-----	-----	-----	-----	-----	-----	-----	-----

7.6.6 “C56” : If No Card Remained inside the unit, STAND-BY for specified time and Write 2 TRACK Data if Card is inserted.

Command Packet

SOH	‘C’	‘5’	‘6’	STX	DATA	ETX	BCC
-----	-----	-----	-----	-----	------	-----	-----

DATA : 1 – 37 Byte ASCII(NUMERIC Only) String

Positive Response Packet

SOH	‘C’	‘5’	‘6’	STX	‘P’	STATUS	ETX	BCC
-----	-----	-----	-----	-----	-----	--------	-----	-----

Negative Response Packet

SOH	‘C’	‘5’	‘6’	STX	‘N’	ST1	ST2	ETX	BCC
-----	-----	-----	-----	-----	-----	-----	-----	-----	-----

Doc No	KYT6XXX Series SPECIFICATION	REV	PAGE	DATE
91000050		J	28 OF 63	2017.03 .20.

7.6.7 “C57” : If No Card Remained inside the unit, STAND-BY for specified time and Write 3 TRACK Data if Card is inserted.

Command Packet

SOH	‘C’	‘5’	‘7’	STX	DATA	ETX	BCC
-----	-----	-----	-----	-----	------	-----	-----

DATA : 1 – 104 Byte ASCII(NUMERIC) String

Positive Response Packet

SOH	‘C’	‘5’	‘7’	STX	‘P’	STATUS	ETX	BCC
-----	-----	-----	-----	-----	-----	--------	-----	-----

Negative Response Packet

SOH	‘C’	‘5’	‘7’	STX	‘N’	ST1	ST2	ETX	BCC
-----	-----	-----	-----	-----	-----	-----	-----	-----	-----

7.7 Magnetic Binary Data Read.

7.7.1 “B40” : If Card Remained inside the unit , Track Data Read

Command Packet

SOH	‘B’	‘4’	‘0’	STX	ETX	BCC
-----	-----	-----	-----	-----	-----	-----

Positive Response Packet

SOH	‘B’	‘4’	‘0’	STX	‘P’	STATUS	DATA	ETX	BCC
-----	-----	-----	-----	-----	-----	--------	------	-----	-----

Negative Response Packet

SOH	‘B’	‘4’	‘0’	STX	‘N’	ST1	ST2	ETX	BCC
-----	-----	-----	-----	-----	-----	-----	-----	-----	-----

7.7.2 “B41” : If Card Remained inside the unit, 2 Track Data Read

Command Packet

SOH	‘B’	‘4’	‘1’	STX	ETX	BCC
-----	-----	-----	-----	-----	-----	-----

Positive Response Packet

SOH	‘B’	‘4’	‘1’	STX	‘P’	STATUS	DATA	ETX	BCC
-----	-----	-----	-----	-----	-----	--------	------	-----	-----

Negative Response Packet

SOH	‘B’	‘4’	‘1’	STX	‘N’	ST1	ST2	ETX	BCC
-----	-----	-----	-----	-----	-----	-----	-----	-----	-----

7.7.3 “B42” : If Card Remained inside the unit, 3 Track Data Read

Command Packet

SOH	‘B’	‘4’	‘2’	STX	ETX	BCC
-----	-----	-----	-----	-----	-----	-----

Positive Response Packet

SOH	‘B’	‘4’	‘2’	STX	‘P’	STATUS	DATA	ETX	BCC
-----	-----	-----	-----	-----	-----	--------	------	-----	-----

Negative Response Packet

SOH	‘B’	‘4’	‘2’	STX	‘N’	ST1	ST2	ETX	BCC
-----	-----	-----	-----	-----	-----	-----	-----	-----	-----

Doc No	KYT6XXX Series SPECIFICATION	REV	PAGE	DATE
91000050		J	29 OF 63	2017.03 .20.

7.7.4 “B43” : If Card Remained inside the unit, ALL Track(1, 2, 3 Track) Data Read

Command Packet

SOH	‘B’	‘4’	‘3’	STX	ETX	BCC
-----	-----	-----	-----	-----	-----	-----

Positive Response Packet

SOH	‘B’	‘4’	‘3’	STX	‘P’	STATUS	DATA	ETX	BCC
-----	-----	-----	-----	-----	-----	--------	------	-----	-----

DATA Structure

1 Track Data	00h	2 Track Data	00h	3 Track Data
--------------	-----	--------------	-----	--------------

Return Negative Code in case of Read Error (Ref. : Negative Response Code List)

Negative Response Packet

SOH	‘B’	‘4’	‘3’	STX	‘N’	ST1	ST2	ETX	BCC
-----	-----	-----	-----	-----	-----	-----	-----	-----	-----

7.7.5 “B45” : If No Card Remained inside the unit, STAND-BY for specified time and Read 1 TRACK

Data if Card is inserted.

Command Packet

SOH	‘B’	‘4’	‘5’	STX	ETX	BCC
-----	-----	-----	-----	-----	-----	-----

Positive Response Packet

SOH	‘B’	‘4’	‘5’	STX	‘P’	STATUS	DATA	ETX	BCC
-----	-----	-----	-----	-----	-----	--------	------	-----	-----

Negative Response Packet

SOH	‘B’	‘4’	‘5’	STX	‘N’	ST1	ST2	ETX	BCC
-----	-----	-----	-----	-----	-----	-----	-----	-----	-----

7.7.6 “B46” : If No Card Remained inside the unit, STAND-BY for specified time and Read 2 TRACK

Data if Card is inserted.

Command Packet

SOH	‘B’	‘4’	‘6’	STX	ETX	BCC
-----	-----	-----	-----	-----	-----	-----

Positive Response Packet

SOH	‘B’	‘4’	‘6’	STX	‘P’	STATUS	DATA	ETX	BCC
-----	-----	-----	-----	-----	-----	--------	------	-----	-----

Negative Response Packet

SOH	‘B’	‘4’	‘6’	STX	‘N’	ST1	ST2	ETX	BCC
-----	-----	-----	-----	-----	-----	-----	-----	-----	-----

7.7.7 “C47” : If No Card Remained inside the unit, STAND-BY for specified time and Read 3 TRACK

Data if Card is inserted.

Command Packet

SOH	‘B’	‘4’	‘7’	STX	ETX	BCC
-----	-----	-----	-----	-----	-----	-----

Positive Response Packet

SOH	‘B’	‘4’	‘7’	STX	‘P’	STATUS	DATA	ETX	BCC
-----	-----	-----	-----	-----	-----	--------	------	-----	-----

Negative Response Packet

SOH	‘B’	‘4’	‘7’	STX	‘N’	ST1	ST2	ETX	BCC
-----	-----	-----	-----	-----	-----	-----	-----	-----	-----

Doc No	KYT6XXX Series SPECIFICATION	REV	PAGE	DATE
91000050		J	30 OF 63	2017.03 .20.

7.7.8 “C48” : If No Card Remained inside the unit, STAND-BY for specified time and Read 1,2,3 all TRACK Data if Card is inserted.

Command Packet

SOH	‘B’	‘4’	‘8’	STX	ETX	BCC
-----	-----	-----	-----	-----	-----	-----

Positive Response Packet

SOH	‘B’	‘4’	‘8’	STX	‘P’	STATUS	DATA	ETX	BCC
-----	-----	-----	-----	-----	-----	--------	------	-----	-----

DATA Structure

1 Track Data	00h	2 Track Data	00h	3 Track Data
--------------	-----	--------------	-----	--------------

Return Negative Code in case of Read Error (Ref. : Negative Response Code List)

Negative Response Packet

SOH	‘C’	‘4’	‘8’	STX	‘N’	ST1	ST2	ETX	BCC
-----	-----	-----	-----	-----	-----	-----	-----	-----	-----

7.8 Binary Magnetic Data Write.

7.8.1 “B50” : If Card Remained inside the unit, 1 Track Data Write

Command Packet

SOH	‘C’	‘5’	‘0’	STX	DATA	ETX	BCC
-----	-----	-----	-----	-----	------	-----	-----

Write Data : 1 – 130Byte ASCII(0 ~9, A~F) String

Positive Response Packet

SOH	‘C’	‘5’	‘0’	STX	‘P’	STATUS	ETX	BCC
-----	-----	-----	-----	-----	-----	--------	-----	-----

Negative Response Packet

SOH	‘C’	‘5’	‘0’	STX	‘N’	ST1	ST2	ETX	BCC
-----	-----	-----	-----	-----	-----	-----	-----	-----	-----

7.8.2 “B51” : If Card Remained inside the unit, 3 Track Data Write

Command Packet

SOH	‘C’	‘5’	‘1’	STX	DATA	ETX	BCC
-----	-----	-----	-----	-----	------	-----	-----

Write Data : 1 – 130Byte ASCII(0 ~9, A~F) String

Positive Response Packet

SOH	‘C’	‘5’	‘1’	STX	‘P’	STATUS	ETX	BCC
-----	-----	-----	-----	-----	-----	--------	-----	-----

Negative Response Packet

SOH	‘C’	‘5’	‘1’	STX	‘N’	ST1	ST2	ETX	BCC
-----	-----	-----	-----	-----	-----	-----	-----	-----	-----

7.8.3 “B52” : If Card Remained inside the unit, 2 Track Data Write

Command Packet

SOH	‘B’	‘5’	‘2’	STX	DATA	ETX	BCC
-----	-----	-----	-----	-----	------	-----	-----

Write Data : 1 – 130Byte ASCII(0 ~9, A~F) String

Positive Response Packet

SOH	‘B’	‘5’	‘2’	STX	‘P’	STATUS	ETX	BCC
-----	-----	-----	-----	-----	-----	--------	-----	-----

Negative Response Packet

SOH	‘B’	‘5’	‘2’	STX	‘N’	ST1	ST2	ETX	BCC
-----	-----	-----	-----	-----	-----	-----	-----	-----	-----

Doc No	KYT6XXX Series SPECIFICATION	REV	PAGE	DATE
91000050		J	31 OF 63	2017.03 .20.

7.8.5 “C55” : If No Card Remained inside the unit, STAND-BY for specified time and Write 1 TRACK

Data if Card is inserted.

Command Packet

SOH	‘B’	‘5’	‘5’	STX	DATA	ETX	BCC
-----	-----	-----	-----	-----	------	-----	-----

Write Data : 1 – 130Byte ASCII(0 ~9, A~F) String

Positive Response Packet

SOH	‘B’	‘5’	‘5’	STX	‘P’	STATUS	ETX	BCC
-----	-----	-----	-----	-----	-----	--------	-----	-----

Negative Response Packet

SOH	‘B’	‘5’	‘5’	STX	‘N’	ST1	ST2	ETX	BCC
-----	-----	-----	-----	-----	-----	-----	-----	-----	-----

7.8.6 “C56” : If No Card Remained inside the unit, STAND-BY for specified time and Write 3 TRACK

Data if Card is inserted.

Command Packet

SOH	‘C’	‘5’	‘6’	STX	DATA	ETX	BCC
-----	-----	-----	-----	-----	------	-----	-----

Write Data : 1 – 130Byte ASCII(0 ~9, A~F) String

Positive Response Packet

SOH	‘C’	‘5’	‘6’	STX	‘P’	STATUS	ETX	BCC
-----	-----	-----	-----	-----	-----	--------	-----	-----

Negative Response Packet

SOH	‘C’	‘5’	‘6’	STX	‘N’	ST1	ST2	ETX	BCC
-----	-----	-----	-----	-----	-----	-----	-----	-----	-----

7.8.7 “C57” : If No Card Remained inside the unit, STAND-BY for specified time and Write 2 TRACK

Data if Card is inserted.

Command Packet

SOH	‘C’	‘5’	‘7’	STX	DATA	ETX	BCC
-----	-----	-----	-----	-----	------	-----	-----

Write Data : 1 – 130Byte ASCII(0 ~9, A~F) String

Positive Response Packet

SOH	‘C’	‘5’	‘7’	STX	‘P’	STATUS	ETX	BCC
-----	-----	-----	-----	-----	-----	--------	-----	-----

Negative Response Packet

SOH	‘C’	‘5’	‘7’	STX	‘N’	ST1	ST2	ETX	BCC
-----	-----	-----	-----	-----	-----	-----	-----	-----	-----

Doc No	KYT6XXX Series SPECIFICATION	REV	PAGE	DATE
91000050		J	32 OF 63	2017.03 .20.

7.9 IC Card Control

7.9.1 "C65" : ICC Direct Control

This is a command for operation under ISO 7816 T= 0 . Accordingly , user can handle all IC cards conforming to ISO 7816 – 4 and T = 0, T=1.

Command Packet

SOH	'C'	'6'	'5'	STX	DATA	ETX	BCC
-----	-----	-----	-----	-----	------	-----	-----

Positive Response Packet

SOH	'C'	'6'	'5'	STX	'P'	STATUS	DATA	ETX	BCC
-----	-----	-----	-----	-----	-----	--------	------	-----	-----

DATA Structure

Length_High	Length_Low	RESULT
2BYTE Length		Length

Negative Response Packet

SOH	'C'	'6'	'5'	STX	'N'	ST1	ST2	ETX	BCC
-----	-----	-----	-----	-----	-----	-----	-----	-----	-----

- Note : Add to Data block of above Command Packet Command Packet specified in ISO 7816-4 APDU.

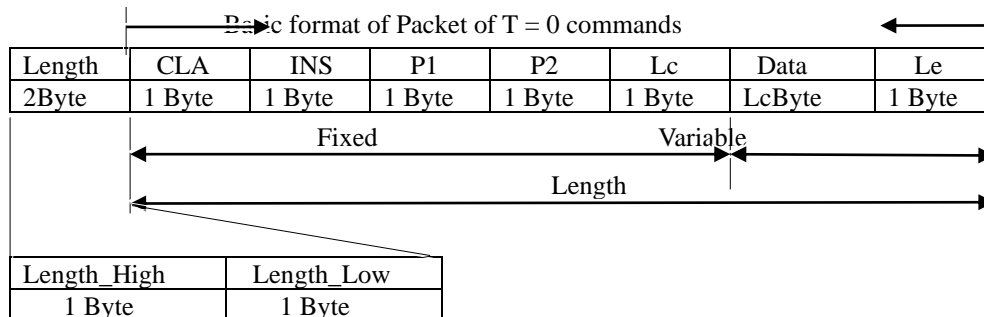

CLA	Class	
INS	Instruction	
P1	Offset(High Value)	
P2	Offset(Low Value)	
Lc	A number of data to transfer	Max Value: 255
Data	Data to transfer	
Le	A number of data to receive	

Format of T=0 command is composed of followings ;

Doc No	KYT6XXX Series SPECIFICATION	REV	PAGE	DATE
91000050		J	33 OF 63	2017.03 .20.

7.9.2 “C68” : Command for sending Reset Signal Contacted IC Card and for

receiving ATR from IC Card.

Command Packet

SOH	‘C’	‘6’	‘8’	STX	ETX	BCC
-----	-----	-----	-----	-----	-----	-----

Positive Response Packet

SOH	‘C’	‘6’	‘8’	STX	‘P’	STATUS	DATA	ETX	BCC
-----	-----	-----	-----	-----	-----	--------	------	-----	-----

DATA of above Positive Response Packet is ATR data received from IC card after Reset signal is sent to IC card . The format of DATA is as follows ;

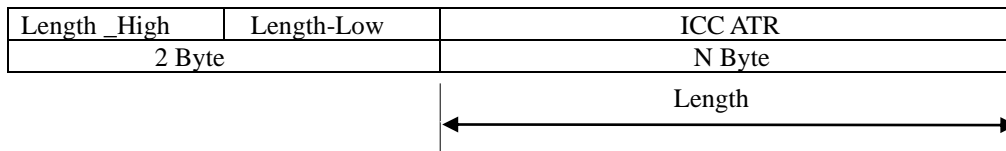

EX)

3B	6B	00	00	80	31	90	63	53	46	01	83	03	90	00
----	----	----	----	----	----	----	----	----	----	----	----	----	----	----

Negative Response Packet

SOH	‘C’	‘6’	‘8’	STX	‘N’	ST1	ST2	ETX	BCC
-----	-----	-----	-----	-----	-----	-----	-----	-----	-----

Doc No	KYT6XXX Series SPECIFICATION	REV	PAGE	DATE
91000050		J	34 OF 63	2017.03 .20.

7.10 RF Card Control

7.10.1 “R10” : Identify the sector and block set at terminal.

Command Packet

SOH	'R'	'1'	'0'	STX	ETX	BCC
-----	-----	-----	-----	-----	-----	-----

Positive Response Packet

SOH	'R'	'1'	'0'	STX	'P'	STATUS	DATA	ETX	BCC
-----	-----	-----	-----	-----	-----	--------	------	-----	-----

DATA Structure

Length_High	Length_Low	RESULT
2BYTE Length		Length

Negative Response Packet

SOH	'R'	'1'	'0'	STX	'N'	ST1	ST2	ETX	BCC
-----	-----	-----	-----	-----	-----	-----	-----	-----	-----

7.10.2 “R11” : Identify whether if the antenna detect the card.

Command Packet

SOH	'R'	'1'	'1'	STX	ETX	BCC
-----	-----	-----	-----	-----	-----	-----

Positive Response Packet

SOH	'R'	'1'	'1'	STX	'P'	STATUS	DATA	ETX	BCC
-----	-----	-----	-----	-----	-----	--------	------	-----	-----

DATA Structure

Length_High	Length_Low	RESULT
2BYTE Length		Length

Result Structure.

Result	Detail
0x00	Card Non-Detection(= No Card)
0x01	Card Detection

Negative Response Packet

SOH	'R'	'1'	'1'	STX	'N'	ST1	ST2	ETX	BCC
-----	-----	-----	-----	-----	-----	-----	-----	-----	-----

7.10.3 “R12” : Change the sector and block set at terminal.

Command Packet

SOH	'R'	'1'	'2'	STX	DATA	ETX	BCC
-----	-----	-----	-----	-----	------	-----	-----

DATA Structure

Length_High	Length_Low	Sector&Block
2BYTE Length		Length

Result Structure.

BYTE	
1 Byte	Sector
2 Byte	Block

Positive Response Packet

SOH	'R'	'1'	'2'	STX	'P'	STATUS	ETX	BCC
-----	-----	-----	-----	-----	-----	--------	-----	-----

Negative Response Packet

SOH	'R'	'1'	'2'	STX	'N'	ST1	ST2	ETX	BCC
-----	-----	-----	-----	-----	-----	-----	-----	-----	-----

Doc No	KYT6XXX Series SPECIFICATION	REV	PAGE	DATE
91000050		J	35 OF 63	2017.03 .20.

7.10.4 “R13” : authentication key Read (KeyA or KeyB).

Command Packet

SOH	‘R’	‘1’	‘3’	STX	ETX	BCC
-----	-----	-----	-----	-----	-----	-----

Positive Response Packet

SOH	‘R’	‘1’	‘3’	STX	‘P’	STATUS	DATA	ETX	BCC
-----	-----	-----	-----	-----	-----	--------	------	-----	-----

DATA Structure

Length_High	Length_Low	RESULT
2BYTE Length		Length

Result Structure.

Result	
0x00	Secret key A
0x01	Secret key B

Negative Response Packet

SOH	‘R’	‘1’	‘3’	STX	‘N’	ST1	ST2	ETX	BCC
-----	-----	-----	-----	-----	-----	-----	-----	-----	-----

7.10.5 “R14” : Get the RF Card’s serial.

Command Packet

SOH	‘R’	‘1’	‘4’	STX	ETX	BCC
-----	-----	-----	-----	-----	-----	-----

Positive Response Packet

SOH	‘R’	‘1’	‘3’	STX	‘P’	STATUS	DATA	ETX	BCC
-----	-----	-----	-----	-----	-----	--------	------	-----	-----

DATA Structure

Length_High	Length_Low	RESULT
4BYTE Length		Length

Result Structure.

LSB		MSB
-----	--	-----

Negative Response Packet

SOH	‘R’	‘1’	‘4’	STX	‘N’	ST1	ST2	ETX	BCC
-----	-----	-----	-----	-----	-----	-----	-----	-----	-----

7.10.6 “R15” : Select the authentication key: KeyA or KeyB.

Command Packet

SOH	‘R’	‘1’	‘5’	STX	DATA	ETX	BCC
-----	-----	-----	-----	-----	------	-----	-----

DATA Structure

Length_High	Length_Low	Secret key Data
1BYTE Length		Length

Secret key Data	
0x00	Secret key A
0x01	Secret key B

Positive Response Packet

SOH	‘R’	‘1’	‘5’	STX	‘P’	STATUS	ETX	BCC
-----	-----	-----	-----	-----	-----	--------	-----	-----

Negative Response Packet

SOH	‘R’	‘1’	‘5’	STX	‘N’	ST1	ST2	ETX	BCC
-----	-----	-----	-----	-----	-----	-----	-----	-----	-----

Doc No	KYT6XXX Series SPECIFICATION	REV	PAGE	DATE
91000050		J	36 OF 63	2017.03 .20.

7.10.6 “R20” : RF Card Data(balance or character) Read.

Command Packet

SOH	‘R’	‘2’	‘0’	STX	ETX	BCC
-----	-----	-----	-----	-----	-----	-----

Positive Response Packet

SOH	‘R’	‘2’	‘0’	STX	‘P’	STATUS	DATA	ETX	BCC
-----	-----	-----	-----	-----	-----	--------	------	-----	-----

DATA Structure

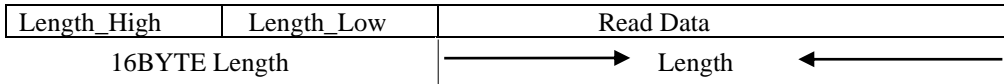

Read Data Structure.

D0	D1	D2	---	D14	D15
1Byte	1Byte	1Byte	---	1Byte	1Byte

Negative Response Packet

SOH	‘R’	‘2’	‘0’	STX	‘N’	ST1	ST2	ETX	BCC
-----	-----	-----	-----	-----	-----	-----	-----	-----	-----

7.10.7 “R21” : RF Card Data (balance) Read.

Command Packet

SOH	‘R’	‘2’	‘1’	STX	ETX	BCC
-----	-----	-----	-----	-----	-----	-----

Positive Response Packet

SOH	‘R’	‘2’	‘1’	STX	‘P’	STATUS	DATA	ETX	BCC
-----	-----	-----	-----	-----	-----	--------	------	-----	-----

DATA Structure

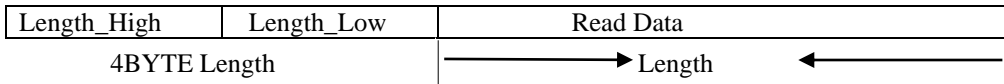

Result Structure.

D0	D1	D2	D3
1Byte	1Byte	1Byte	1Byte

Negative Response Packet

SOH	‘R’	‘2’	‘1’	STX	‘N’	ST1	ST2	ETX	BCC
-----	-----	-----	-----	-----	-----	-----	-----	-----	-----

7.10.8 “R22” : RF Card Data (balance) Write.

Command Packet

SOH	‘R’	‘2’	‘2’	STX	DATA	ETX	BCC
-----	-----	-----	-----	-----	------	-----	-----

DATA Structure

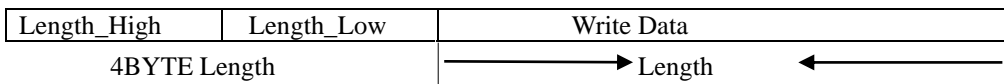

Write Data Structure : 0x00000000 ~ 0xffffffff

D0	D1	D2	D3
1Byte	1Byte	1Byte	1Byte

Ex) DATA(balance) : ‘1000’

D0	D1	D2	D3
0xe8	0x03	0x00	0x00

Positive Response Packet

SOH	‘R’	‘2’	‘2’	STX	‘P’	STATUS	ETX	BCC
-----	-----	-----	-----	-----	-----	--------	-----	-----

Doc No	KYT6XXX Series SPECIFICATION	REV	PAGE	DATE
91000050		J	37 OF 63	2017.03 .20.

Negative Response Packet

SOH	'R'	'2'	'2'	STX	'N'	ST1	ST2	ETX	BCC
-----	-----	-----	-----	-----	-----	-----	-----	-----	-----

7.10.9 "R23" : RF Card Data (balance or character) Write.

Command Packet

SOH	'R'	'2'	'3'	STX	DATA	ETX	BCC
-----	-----	-----	-----	-----	------	-----	-----

DATA Structure

Length_High	Length_Low	Read Data
16BYTE Length		

Data Structure.

D0	D1	D2	---	D14	D15
1Byte	1Byte	1Byte	---	1Byte	1Byte

Ex) DATA(character) : 'KYTRONICS'

D0	D1	D2	D3	D4	---	D12	D13	D14	D15
0x4b	0x59	0x54	0x52	0x4f	---	0x00	0x00	0x00	0x00

Positive Response Packet

SOH	'R'	'2'	'3'	STX	'P'	STATUS	ETX	BCC
-----	-----	-----	-----	-----	-----	--------	-----	-----

Negative Response Packet

SOH	'R'	'2'	'3'	STX	'N'	ST1	ST2	ETX	BCC
-----	-----	-----	-----	-----	-----	-----	-----	-----	-----

7.10.10 "R24" : Increment the balance of card to the specified amount.

Command Packet

SOH	'R'	'2'	'4'	STX	DATA	ETX	BCC
-----	-----	-----	-----	-----	------	-----	-----

DATA Structure

Length_High	Length_Low	Increment Data
4BYTE Length		

Increment Data Structure : 0x00000000 ~ 0xffffffff

D0	D1	D2	D3
1Byte	1Byte	1Byte	1Byte

Ex) DATA(balance) : '1000'

D0	D1	D2	D3
0xe8	0x03	0x00	0x00

Positive Response Packet

SOH	'R'	'2'	'4'	STX	'P'	STATUS	ETX	BCC
-----	-----	-----	-----	-----	-----	--------	-----	-----

Negative Response Packet

SOH	'R'	'2'	'4'	STX	'N'	ST1	ST2	ETX	BCC
-----	-----	-----	-----	-----	-----	-----	-----	-----	-----

Doc No	KYT6XXX Series SPECIFICATION	REV	PAGE	DATE
91000050		J	38 OF 63	2017.03 .20.

7.10.11 “R25” : Decrement the balance of card to the specified amount..

Command Packet

SOH	'R'	'2'	'5'	STX	DATA	ETX	BCC
-----	-----	-----	-----	-----	------	-----	-----

DATA Structure

Length_High	Length_Low	Decrement Data
16BYTE Length		

Decrement Data Structure : 0x00000000 ~ 0xffffffff

D0	D1	D2	---	D14	D15
1Byte	1Byte	1Byte	---	1Byte	1Byte

Ex) DATA(balance) : '1000'

D0	D1	D2	D3
0xe8	0x03	0x00	0x00

Positive Response Packet

SOH	'R'	'2'	'5'	STX	'P'	STATUS	ETX	BCC
-----	-----	-----	-----	-----	-----	--------	-----	-----

Negative Response Packet

SOH	'R'	'2'	'5'	STX	'N'	ST1	ST2	ETX	BCC
-----	-----	-----	-----	-----	-----	-----	-----	-----	-----

7.10.12 “R2A” : RF Card Data(balance or character) Read.

Command Packet

SOH	'R'	'2'	'A'	STX	DATA	ETX	BCC
-----	-----	-----	-----	-----	------	-----	-----

DATA Structure

Length_High	Length_Low	Secret key&Sector&Block&Key
9BYTE Length		

Ex) Secret key&Sector&Block&Key Structure

V0	V1	V2	V3	V4	V5	V6	V7	V8
Secret key	Sector	Block	Key 0	Key 1	Key 2	Key 3	Key 4	Key 5

Ex) Secret : Key A, Sector : 0, Block : 0, Key Value : 0xff,0xff,0xff,0xff,0xff,0xff

V0	V1	V2	V3	V4	V5	V6	V7	V8
0x00	0x00	0x00	0xff	0xff	0xff	0xff	0xff	0xff

Positive Response Packet

SOH	'R'	'2'	'A'	STX	'P'	STATUS	DATA	ETX	BCC
-----	-----	-----	-----	-----	-----	--------	------	-----	-----

DATA Structure

Length_High	Length_Low	Read Data
16BYTE Length		

Read Data Structure.

D0	D1	D2	---	D14	D15
1Byte	1Byte	1Byte	---	1Byte	1Byte

Negative Response Packet

SOH	'R'	'2'	'0'	STX	'N'	ST1	ST2	ETX	BCC
-----	-----	-----	-----	-----	-----	-----	-----	-----	-----

Doc No	KYT6XXX Series SPECIFICATION	REV	PAGE	DATE
91000050		J	39 OF 63	2017.03 .20.

7.10.13 “R2B” : RF Card Data (balance) Read.

Command Packet

SOH	‘R’	‘2’	‘B’	STX	DATA	ETX	BCC
-----	-----	-----	-----	-----	------	-----	-----

DATA Structure

Length_High	Length_Low	Secret key&Sector&Block&Key
9BYTE Length		→ Length ←

Ex) Secret key&Sector&Block&Key Structure

V0	V1	V2	V3	V4	V5	V6	V7	V8
Secret key	Sector	Block	Key 0	Key 1	Key 2	Key 3	Key 4	Key 5

Ex) Secret : Key A, Sector : 0, Block : 0, Key Value : 0xff,0xff,0xff,0xff,0xff,0xff

V0	V1	V2	V3	V4	V5	V6	V7	V8
0x00	0x00	0x00	0xff	0xff	0xff	0xff	0xff	0xff

Positive Response Packet

SOH	‘R’	‘2’	‘B’	STX	‘P’	STATUS	DATA	ETX	BCC
-----	-----	-----	-----	-----	-----	--------	------	-----	-----

DATA Structure

Length_High	Length_Low	Read Data
4BYTE Length		→ Length ←

Result Structure.

D0	D1	D2	D3
1Byte	1Byte	1Byte	1Byte

Negative Response Packet

SOH	‘R’	‘2’	‘B’	STX	‘N’	ST1	ST2	ETX	BCC
-----	-----	-----	-----	-----	-----	-----	-----	-----	-----

7.10.14 “R2C” : RF Card Data (balance) Write.

Command Packet

SOH	‘R’	‘2’	‘C’	STX	DATA	ETX	BCC
-----	-----	-----	-----	-----	------	-----	-----

DATA Structure

Length_High	Length_Low	Secret key&Sector&Block&Key
25BYTE Length		→ Length ←

Ex) Secret key&Sector&Block&Key Structure

V0	V1	V2	V3	V4	V5	V6	V7	V8
Secret key	Sector	Block	Key 0	Key 1	Key 2	Key 3	Key 4	Key 5
V9	V10	V11	V12					
B0	B1	B2	B3					
Balance Data								

Ex) Secret : Key A, Sector : 0, Block : 0, Key Value : 0xff,0xff,0xff,0xff,0xff,0xff

V0	V1	V2	V3	V4	V5	V6	V7	V8
0x00	0x00	0x00	0xff	0xff	0xff	0xff	0xff	0xff

DATA(balance) : ‘1000’

B0	B1	B2	B3
0xe8	0x03	0x00	0x00

Doc No	KYT6XXX Series SPECIFICATION	REV	PAGE	DATE
91000050		J	40 OF 63	2017.03 .20.

Positive Response Packet

SOH	'R'	'2'	'3'	STX	'P'	STATUS	ETX	BCC
-----	-----	-----	-----	-----	-----	--------	-----	-----

Negative Response Packet

SOH	'R'	'2'	'3'	STX	'N'	ST1	ST2	ETX	BCC
-----	-----	-----	-----	-----	-----	-----	-----	-----	-----

7.10.15 "R2D" : RF Card Data (balance or character) Write.

Command Packet

SOH	'R'	'2'	'D'	STX	DATA	ETX	BCC
-----	-----	-----	-----	-----	------	-----	-----

DATA Structure

Length_High	Length_Low	Secret key&Sector&Block&Key
25BYTE Length		Length

Ex) Secret key&Sector&Block&Key Structure

V0	V1	V2	V3	V4	V5	V6	V7	V8	
Secret key	Sector	Block	Key 0	Key 1	Key 2	Key 3	Key 4	Key 5	
V9	V10	V11	V12	V13	---	V21	V22	V23	V24
D0	D1	D2	D3	D4	---	D12	D13	D14	D15
Balance or Character Data									

Ex) Secret : Key A, Sector : 0, Block : 0, Key Value : 0xff,0xff,0xff,0xff,0xff,0xff

V0	V1	V2	V3	V4	V5	V6	V7	V8
0x00	0x00	0x00	0xff	0xff	0xff	0xff	0xff	0xff

DATA(Character) : 'KYTRONICS'

Ex) DATA(character) : 'KYTRONICS'

V9	V10	V11	V12	V13	---	V21	V22	V23	V24
0x4b	0x59	0x54	0x52	0x4f	---	0x00	0x00	0x00	0x00

Positive Response Packet

SOH	'R'	'2'	'D'	STX	'P'	STATUS	ETX	BCC
-----	-----	-----	-----	-----	-----	--------	-----	-----

Negative Response Packet

SOH	'R'	'2'	'D'	STX	'N'	ST1	ST2	ETX	BCC
-----	-----	-----	-----	-----	-----	-----	-----	-----	-----

7.10.16 "R2E" : Increment the balance of card to the specified amount.

Command Packet

SOH	'R'	'2'	'E'	STX	DATA	ETX	BCC
-----	-----	-----	-----	-----	------	-----	-----

DATA Structure

Length_High	Length_Low	Secret key&Sector&Block&Key
13BYTE Length		Length

Doc No	KYT6XXX Series SPECIFICATION	REV	PAGE	DATE
91000050		J	41 OF 63	2017.03 .20.

Ex) Secret key&Sector&Block&Key Structure

V0	V1	V2	V3	V4	V5	V6	V7	V8
Secret key	Sector	Block	Key 0	Key 1	Key 2	Key 3	Key 4	Key 5
V9	V10	V11	V12					
B0	B1	B2	B3					
Balance Data								

Ex) Secret : Key A, Sector : 0, Block : 0, Key Value : 0xff,0xff,0xff,0xff,0xff,0xff

V0	V1	V2	V3	V4	V5	V6	V7	V8
0x00	0x00	0x00	0xff	0xff	0xff	0xff	0xff	0xff

DATA(balance) : '1000'

V9	V10	V11	V12
0xe8	0x03	0x00	0x00

Positive Response Packet

SOH	'R'	'2'	'E'	STX	'P'	STATUS	ETX	BCC
-----	-----	-----	-----	-----	-----	--------	-----	-----

Negative Response Packet

SOH	'R'	'2'	'E'	STX	'N'	ST1	ST2	ETX	BCC
-----	-----	-----	-----	-----	-----	-----	-----	-----	-----

7.10.17 "R2F" : Decrement the balance of card to the specified amount..

Command Packet

SOH	'R'	'2'	'F'	STX	DATA	ETX	BCC
-----	-----	-----	-----	-----	------	-----	-----

DATA Structure

Length_High	Length_Low	Secret key&Sector&Block&Key
13BYTE Length		← Length →

Ex) Secret key&Sector&Block&Key Structure

V0	V1	V2	V3	V4	V5	V6	V7	V8
Secret key	Sector	Block	Key 0	Key 1	Key 2	Key 3	Key 4	Key 5
V9	V10	V11	V12					
B0	B1	B2	B3					
Balance Data								

Ex) Secret : Key A, Sector : 0, Block : 0, Key Value : 0xff,0xff,0xff,0xff,0xff,0xff

V0	V1	V2	V3	V4	V5	V6	V7	V8
0x00	0x00	0x00	0xff	0xff	0xff	0xff	0xff	0xff

DATA(balance) : '1000'

V9	V10	V11	V12
0xe8	0x03	0x00	0x00

Positive Response Packet

SOH	'R'	'2'	'F'	STX	'P'	STATUS	ETX	BCC
-----	-----	-----	-----	-----	-----	--------	-----	-----

Negative Response Packet

SOH	'R'	'2'	'F'	STX	'N'	ST1	ST2	ETX	BCC
-----	-----	-----	-----	-----	-----	-----	-----	-----	-----

Doc No	KYT6XXX Series SPECIFICATION	REV	PAGE	DATE
91000050		J	42 OF 63	2017.03 .20.

7.10.18 “R30” : RF Card Key Change(Access Condition Data Exclude).

Command Packet

SOH	'R'	'3'	'0'	STX	DATA	ETX	BCC
-----	-----	-----	-----	-----	------	-----	-----

DATA Structure

Length_High	Length_Low	Secret key&Sector&Block&Key
13BYTE Length		Length

Ex) Secret key&Sector&Block&Key Structure

V0	V1	V2	V3	V4	V5	V6
Sector	Key A0	Key A1	Key A2	Key A3	Key A4	Key A5
Secret key A						
V7	V8	V9	V10	V11	V12	
KeyB0	KeyB1	KeyB2	KeyB3	KeyB4	KeyB5	
Secret key B						

Positive Response Packet

SOH	'R'	'3'	'0'	STX	'P'	STATUS	ETX	BCC
-----	-----	-----	-----	-----	-----	--------	-----	-----

Negative Response Packet

SOH	'R'	'3'	'0'	STX	'N'	ST1	ST2	ETX	BCC
-----	-----	-----	-----	-----	-----	-----	-----	-----	-----

7.10.19 “R31” : RF Card Key Change(Access Condition Data inclusion).

Command Packet

SOH	'R'	'3'	'1'	STX	DATA	ETX	BCC
-----	-----	-----	-----	-----	------	-----	-----

DATA Structure

Length_High	Length_Low	Secret key&Sector
17BYTE Length		Length

Ex) Secret key&Sector&Block&Key Structure

V0	V1	V2	V3	V4	V5	V6	V7	V8
Sector	KeyA0	KeyA1	KeyA2	KeyA3	KeyA4	KeyA5	Acc0	Acc1
Secret key A							Access	
V9	V10	V11	V12	V13	V14	V15	V16	
Acc3	Acc4	KeyB0	KeyB1	KeyB2	KeyB3	KeyB4	KeyB5	
Condition	Secret key B							

Positive Response Packet

SOH	'R'	'3'	'1'	STX	'P'	STATUS	ETX	BCC
-----	-----	-----	-----	-----	-----	--------	-----	-----

Negative Response Packet

SOH	'R'	'3'	'1'	STX	'N'	ST1	ST2	ETX	BCC
-----	-----	-----	-----	-----	-----	-----	-----	-----	-----

Doc No	KYT6XXX Series SPECIFICATION	REV	PAGE	DATE
91000050		J	43 OF 63	2017.03 .20.

7.10.20 “R32” : Module Key Change.

Command Packet

SOH	‘R’	‘3’	‘2’	STX	DATA	ETX	BCC
-----	-----	-----	-----	-----	------	-----	-----

DATA Structure

Length_High	Length_Low	Secret key&Sector&Block&Key
13BYTE Length		Length

Ex) Secret key&Sector&Block&Key Structure

V0	V1	V2	V3	V4	V5	V6
Sector	Key A0	Key A1	Key A2	Key A3	Key A4	Key A5
Secret key A						
V7	V8	V9	V10	V11	V12	
KeyB0	KeyB1	KeyB2	KeyB3	KeyB4	KeyB5	
Secret key B						

Positive Response Packet

SOH	‘R’	‘3’	‘2’	STX	‘P’	STATUS	ETX	BCC
-----	-----	-----	-----	-----	-----	--------	-----	-----

Negative Response Packet

SOH	‘R’	‘3’	‘2’	STX	‘N’	ST1	ST2	ETX	BCC
-----	-----	-----	-----	-----	-----	-----	-----	-----	-----

7.10.21 “R40” : Power On (The carrier wave emitted in antenna.)

Command Packet

SOH	‘R’	‘4’	‘0’	STX	ETX	BCC
-----	-----	-----	-----	-----	-----	-----

Positive Response Packet

SOH	‘R’	‘2’	‘F’	STX	‘P’	STATUS	ETX	BCC
-----	-----	-----	-----	-----	-----	--------	-----	-----

Negative Response Packet

SOH	‘R’	‘2’	‘F’	STX	‘N’	ST1	ST2	ETX	BCC
-----	-----	-----	-----	-----	-----	-----	-----	-----	-----

7.10.22 “R41” : Power Off(The carrier wave not emitted in antenna.)

Command Packet

SOH	‘R’	‘4’	‘1’	STX	ETX	BCC
-----	-----	-----	-----	-----	-----	-----

Positive Response Packet

SOH	‘R’	‘4’	‘1’	STX	‘P’	STATUS	ETX	BCC
-----	-----	-----	-----	-----	-----	--------	-----	-----

Negative Response Packet

SOH	‘R’	‘4’	‘1’	STX	‘N’	ST1	ST2	ETX	BCC
-----	-----	-----	-----	-----	-----	-----	-----	-----	-----

Doc No	KYT6XXX Series SPECIFICATION	REV	PAGE	DATE
91000050		J	44 OF 63	2017.03 .20.

7.11 Retry Setting

7.11.1 "C70" : No RETRY in case of Data Error

Command Packet

SOH	'C'	'7'	'0'	STX	ETX	BCC
-----	-----	-----	-----	-----	-----	-----

Positive Response Packet

SOH	'C'	'7'	'0'	STX	'P'	STATUS	ETX	BCC
-----	-----	-----	-----	-----	-----	--------	-----	-----

Negative Response Packet

SOH	'C'	'7'	'0'	STX	'N'	ST1	ST2	ETX	BCC
-----	-----	-----	-----	-----	-----	-----	-----	-----	-----

7.11.2 "C71" : Set Read RETRY 1 time in case of Data Error

Command Packet

SOH	'C'	'7'	'1'	STX	ETX	BCC
-----	-----	-----	-----	-----	-----	-----

Positive Response Packet

SOH	'C'	'7'	'1'	STX	'P'	STATUS	ETX	BCC
-----	-----	-----	-----	-----	-----	--------	-----	-----

Negative Response Packet

SOH	'C'	'7'	'1'	STX	'N'	ST1	ST2	ETX	BCC
-----	-----	-----	-----	-----	-----	-----	-----	-----	-----

7.11.3 "C72" : Set Read RETRY 2 time in case of Data Error

Command Packet

SOH	'C'	'7'	'2'	STX	ETX	BCC
-----	-----	-----	-----	-----	-----	-----

Positive Response Packet

SOH	'C'	'7'	'2'	STX	'P'	STATUS	ETX	BCC
-----	-----	-----	-----	-----	-----	--------	-----	-----

Negative Response Packet

SOH	'C'	'7'	'2'	STX	'N'	ST1	ST2	ETX	BCC
-----	-----	-----	-----	-----	-----	-----	-----	-----	-----

7.11.4 "C73" : Set Read RETRY 3 time in case of Data Error

Command Packet

SOH	'C'	'7'	'3'	STX	ETX	BCC
-----	-----	-----	-----	-----	-----	-----

Positive Response Packet

SOH	'C'	'7'	'3'	STX	'P'	STATUS	ETX	BCC
-----	-----	-----	-----	-----	-----	--------	-----	-----

Negative Response Packet

SOH	'C'	'7'	'3'	STX	'N'	ST1	ST2	ETX	BCC
-----	-----	-----	-----	-----	-----	-----	-----	-----	-----

7.11.5 "C74" : Set Read RETRY 4 time in case of Data Error

Command Packet

SOH	'C'	'7'	'4'	STX	ETX	BCC
-----	-----	-----	-----	-----	-----	-----

Positive Response Packet

SOH	'C'	'7'	'4'	STX	'P'	STATUS	ETX	BCC
-----	-----	-----	-----	-----	-----	--------	-----	-----

Negative Response Packet

SOH	'C'	'7'	'4'	STX	'N'	ST1	ST2	ETX	BCC
-----	-----	-----	-----	-----	-----	-----	-----	-----	-----

Doc No	KYT6XXX Series SPECIFICATION	REV	PAGE	DATE
91000050		J	45 OF 63	2017.03 .20.

7.12 Head Cleaning

7.12.1 "C80" : Head Cleaning If No Card Remained inside the unit, STAND-

BY for specified time and reciprocate 5 times and eject Cleaning Card if Card is inserted.

Command Packet

SOH	'C'	'8'	'0'	STX	ETX	BCC
-----	-----	-----	-----	-----	-----	-----

Positive Response Packet

SOH	'C'	'8'	'0'	STX	'P'	STATUS	ETX	BCC
-----	-----	-----	-----	-----	-----	--------	-----	-----

Negative Response Packet

SOH	'C'	'8'	'0'	STX	'N'	ST1	ST2	ETX	BCC
-----	-----	-----	-----	-----	-----	-----	-----	-----	-----

7.12.2 "C81" : Command for activating Buzzer once.

Example) To indicate that a command runs "Good" .

Command Packet

SOH	'C'	'8'	'1'	STX	ETX	BCC
-----	-----	-----	-----	-----	-----	-----

Positive Response Packet

SOH	'C'	'8'	'1'	STX	'P'	STATUS	ETX	BCC
-----	-----	-----	-----	-----	-----	--------	-----	-----

Negative Response Packet

SOH	'C'	'8'	'1'	STX	'N'	ST1	ST2	ETX	BCC
-----	-----	-----	-----	-----	-----	-----	-----	-----	-----

7.12.3 "C82" : Command for activating Buzzer twice

Example) To indicate that a command runs "In Error".

Command Packet

SOH	'C'	'8'	'2'	STX	ETX	BCC
-----	-----	-----	-----	-----	-----	-----

Positive Response Packet

SOH	'C'	'8'	'2'	STX	'P'	STATUS	ETX	BCC
-----	-----	-----	-----	-----	-----	--------	-----	-----

Negative Response Packet

SOH	'C'	'8'	'2'	STX	'N'	ST1	ST2	ETX	BCC
-----	-----	-----	-----	-----	-----	-----	-----	-----	-----

Doc No	KYT6XXX Series SPECIFICATION	REV	PAGE	DATE
91000050		J	46 OF 63	2017.03 .20.

7.13 Setting

7.13.1 "C90" : Card Wait Time Set

Command Packet

SOH	'C'	'9'	'0'	STX	DATA	ETX	BCC
-----	-----	-----	-----	-----	------	-----	-----

DATA : Card STAND-BY time to be inserted (sec : "1" – "9")

Positive Response Packet

SOH	'C'	'9'	'0'	STX	'P'	STATUS	ETX	BCC
-----	-----	-----	-----	-----	-----	--------	-----	-----

Negative Response Packet

SOH	'C'	'9'	'0'	STX	'N'	ST1	ST2	ETX	BCC
-----	-----	-----	-----	-----	-----	-----	-----	-----	-----

7.13.2 "C91" : Series(RTS,CTS) Set.

Command Packet

SOH	'C'	'9'	'1'	STX	ETX	BCC
-----	-----	-----	-----	-----	-----	-----

Positive Response Packet

SOH	'C'	'9'	'1'	STX	'P'	STATUS	ETX	BCC
-----	-----	-----	-----	-----	-----	--------	-----	-----

Negative Response Packet

SOH	'C'	'9'	'1'	STX	'N'	ST1	ST2	ETX	BCC
-----	-----	-----	-----	-----	-----	-----	-----	-----	-----

7.13.3 "C92" : Series(RTS,CTS) Cancellation.

Command Packet

SOH	'C'	'9'	'2'	STX	ETX	BCC
-----	-----	-----	-----	-----	-----	-----

Positive Response Packet

SOH	'C'	'9'	'2'	STX	'P'	STATUS	ETX	BCC
-----	-----	-----	-----	-----	-----	--------	-----	-----

Negative Response Packet

SOH	'C'	'9'	'2'	STX	'N'	ST1	ST2	ETX	BCC
-----	-----	-----	-----	-----	-----	-----	-----	-----	-----

7.13.4 "C95" : Baud Rate Setting

Command Packet

SOH	'C'	'9'	'5'	STX	DATA	ETX	BCC
-----	-----	-----	-----	-----	------	-----	-----

DATA :

'0' – 9600 BPS

'1' – 19200 BPS(Default)

'2' – 38400 BPS

'3' – 57600 BPS

Positive Response Packet

SOH	'C'	'9'	'5'	STX	'P'	STATUS	ETX	BCC
-----	-----	-----	-----	-----	-----	--------	-----	-----

Negative Response Packet

SOH	'C'	'9'	'5'	STX	'N'	ST1	ST2	ETX	BCC
-----	-----	-----	-----	-----	-----	-----	-----	-----	-----

Doc No	KYT6XXX Series SPECIFICATION	REV	PAGE	DATE
91000050		J	47 OF 63	2017.03 .20.

7.13.4 “C9A” : Magnetic Card High-co and Low-co select.

Command Packet

SOH	‘C’	‘9’	‘A’	STX	DATA	ETX	BCC
-----	-----	-----	-----	-----	------	-----	-----

DATA :

‘0’ – 3000e(Default)

‘1’ – 17500e.

‘2’ – 27500e

‘3’ – 40000e

Positive Response Packet

SOH	‘C’	‘9’	‘A’	STX	‘P’	STATUS	ETX	BCC
-----	-----	-----	-----	-----	-----	--------	-----	-----

Negative Response Packet

SOH	‘C’	‘9’	‘A’	STX	‘N’	ST1	ST2	ETX	BCC
-----	-----	-----	-----	-----	-----	-----	-----	-----	-----

7.13.5 “C9B” : LED On/Off

Command Packet

SOH	‘C’	‘9’	‘B’	STX	DATA	ETX	BCC
-----	-----	-----	-----	-----	------	-----	-----

DATA :

‘0’ – READ

‘1’ – WRITE

‘2’ – GOOD

‘3’ – ERROR

‘4’ – ALL OFF.

Positive Response Packet

SOH	‘C’	‘9’	‘B’	STX	‘P’	STATUS	ETX	BCC
-----	-----	-----	-----	-----	-----	--------	-----	-----

Negative Response Packet

SOH	‘C’	‘9’	‘B’	STX	‘N’	ST1	ST2	ETX	BCC
-----	-----	-----	-----	-----	-----	-----	-----	-----	-----

6.13.6 “C9C” : Track 2 BPI Select.

Command Packet

SOH	‘C’	‘9’	‘C’	STX	DATA	ETX	BCC
-----	-----	-----	-----	-----	------	-----	-----

DATA :

‘0’ – 75BPI(Default)

‘1’ – 210BPI

Positive Response Packet

SOH	‘C’	‘9’	‘C’	STX	‘P’	STATUS	ETX	BCC
-----	-----	-----	-----	-----	-----	--------	-----	-----

Negative Response Packet

SOH	‘C’	‘9’	‘C’	STX	‘N’	ST1	ST2	ETX	BCC
-----	-----	-----	-----	-----	-----	-----	-----	-----	-----

Doc No	KYT6XXX Series SPECIFICATION	REV	PAGE	DATE
91000050		J	48 OF 63	2017.03 .20.

6.14.7 LCD Display.

* MIAN B/D(SW2)

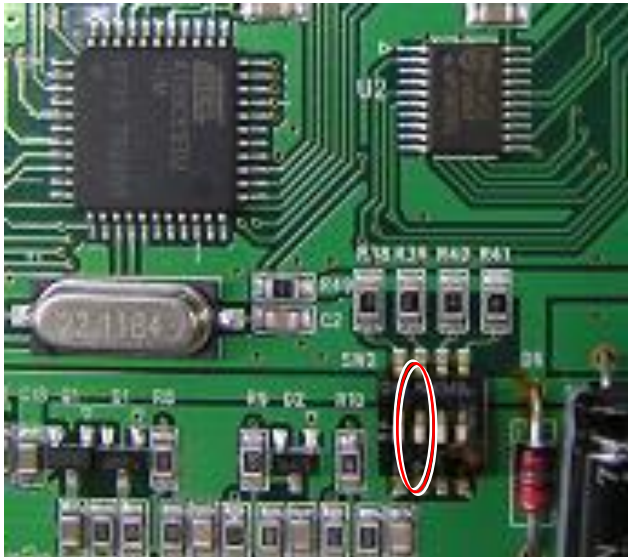

2 PIN : ON (User Mode)

. “L01” : LCD Display to 1Line.

Command Packet

SOH	'L'	'0'	'1'	STX	DATA	ETX	BCC
-----	-----	-----	-----	-----	------	-----	-----

DATA : 16BYTE

Positive Response Packet

SOH	'L'	'0'	'1'	STX	'P'	STATUS	ETX	BCC
-----	-----	-----	-----	-----	-----	--------	-----	-----

Negative Response Packet

SOH	'L'	'0'	'1'	STX	'N'	ST1	ST2	ETX	BCC
-----	-----	-----	-----	-----	-----	-----	-----	-----	-----

. “L02” : LCD Display to 2 Line.

Command Packet

SOH	'L'	'0'	'2'	STX	DATA	ETX	BCC
-----	-----	-----	-----	-----	------	-----	-----

DATA : 16BYTE

Positive Response Packet

SOH	'L'	'0'	'2'	STX	'P'	STATUS	ETX	BCC
-----	-----	-----	-----	-----	-----	--------	-----	-----

Negative Response Packet

SOH	'L'	'0'	'2'	STX	'N'	ST1	ST2	ETX	BCC
-----	-----	-----	-----	-----	-----	-----	-----	-----	-----

Doc No	KYT6XXX Series SPECIFICATION	REV	PAGE	DATE
91000050		J	49 OF 63	2017.03 .20.

7.15. TCP IP.

:When KYT-6912 has connected the Ethernet and there is no receiving data for 30 Seconds, KYT-6912 disconnects and wait the connection.

***You must use a cross cable.**

7.15.1 “T00” : Ethernet Close the connection

Command Packet

SOH	'T'	'0'	'0'	STX	ETX	BCC
-----	-----	-----	-----	-----	-----	-----

Positive Response Packet

SOH	'T'	'0'	'0'	STX	'P'	STATUS	ETX	BCC
-----	-----	-----	-----	-----	-----	--------	-----	-----

Negative Response Packet

SOH	'T'	'0'	'0'	STX	'N'	ST1	ST2	ETX	BCC
-----	-----	-----	-----	-----	-----	-----	-----	-----	-----

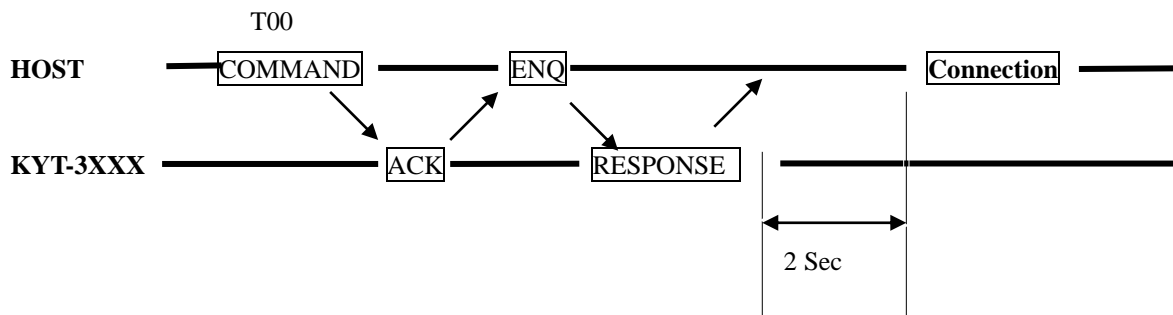

7.15.2 “T01” : TCP IP save.

Command Packet

SOH	'T'	'0'	'1'	STX	ETX	BCC
-----	-----	-----	-----	-----	-----	-----

Positive Response Packet

SOH	'T'	'0'	'1'	STX	'P'	STATUS	DATA	ETX	BCC
-----	-----	-----	-----	-----	-----	--------	------	-----	-----

DATA Structure

'I'	Address	'M'	Address	'G'	Address
-----	---------	-----	---------	-----	---------

Negative Response Packet

SOH	'T'	'0'	'1'	STX	'N'	ST1	ST2	ETX	BCC
-----	-----	-----	-----	-----	-----	-----	-----	-----	-----

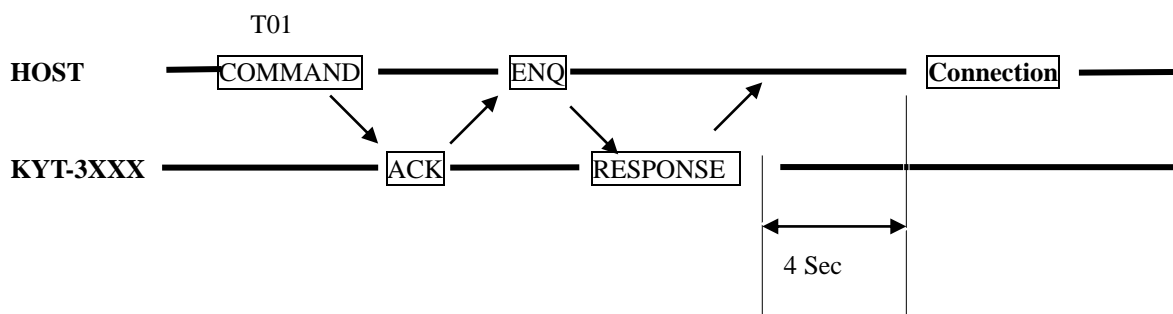

Doc No	KYT6XXX Series SPECIFICATION	REV	PAGE	DATE
91000050		J	50 OF 63	2017.03 .20.

*** initial Ethernet status.**

- . IP address : 100.100.100.133**
- . Sub net mask address : 255.255.255.0**
- . Get way address : 100.100.100.1**

Doc No	KYT6XXX Series SPECIFICATION	REV	PAGE	DATE
91000050		J	51 OF 63	2017.03 .20.

7.16 MIFARE PLUS CARD

Our machine supports the Mifare Plus S(MF1SPLUSx0y1),X(MF1PLUSx0y1) Tags.

With the KYTronics PLUS Command Set the host application don't need to take care about the authentication procedure, AES crypto or CRC32 calculation.

The load data (data bytes in a command/response) are transferred in plain text between the reader and the host, because the AES decryption and encryption takes place completely in our reader.

Firmware function in case of PLUS:

- AES Mutual three pass authentication procedure
- AES CBC (Cipher Block Chaining) send mode
- AES CBC (Cipher Block Chaining) receive mode
- AES padding bytes handling

Doc No	KYT6XXX Series SPECIFICATION	REV	PAGE	DATE
91000050		J	52 OF 63	2017.03 .20.

7.16.1 “E01” : Write Perso.

This command is used to change the data and AES keys from the initial delivery configuration to a customer specific value. Refer to PLUS Datasheet > Write Perso < to get more command details.

Command Packet

SOH	'E'	'0'	'1'	STX	DATA Lengh High	Lengh Low	DATA	ETX	BCC
-----	-----	-----	-----	-----	-----------------	-----------	------	-----	-----

DATA Structure

Block Address	Data or AES KEY
2byte (LSB First)	16 byte

Positive Response Packet

SOH	'E'	'0'	'1'	STX	'P'	STATUS	DATA Length High	Length Low	DATA	ETX	BCC
-----	-----	-----	-----	-----	-----	--------	------------------	------------	------	-----	-----

DATA Structure

The First byte is Status Code by Plus PICC(Refer to PLUS Datasheet). 0x90 is good status or Error code.

Status Code
1 byte

Negative Response Packet

SOH	'E'	'0'	'1'	STX	'N'	ST1	ST2	ETX	BCC
-----	-----	-----	-----	-----	-----	-----	-----	-----	-----

7.16.2 “E02” : Commit Perso.

This command is used to finalize the personalization and switch up to security level 1 or level3.

Refer to PLUS Datasheet > Commit Perso < to get more command details.

Command Packet

SOH	'E'	'0'	'2'	STX	ETX	BCC
-----	-----	-----	-----	-----	-----	-----

Positive Response Packet

SOH	'E'	'0'	'2'	STX	'P'	STATUS	DATA Length High	Length Low	DATA	ETX	BCC
-----	-----	-----	-----	-----	-----	--------	------------------	------------	------	-----	-----

DATA Structure

The First byte is Status Code by Plus PICC(Refer to PLUS Datasheet). 0x90 is good status or Error code.

Status Code
1 byte

Negative Response Packet

SOH	'E'	'0'	'2'	STX	'N'	ST1	ST2	ETX	BCC
-----	-----	-----	-----	-----	-----	-----	-----	-----	-----

Doc No	KYT6XXX Series SPECIFICATION	REV	PAGE	DATE
91000050		J	53 OF 63	2017.03 .20.

7.16.3 “E04” : Level 1 Authentication.

This command is used to authenticate the security level1. Refer to PLUS Datasheet to get more command details.

Command Packet

SOH	'E'	'0'	'4'	STX	DATA Lengh High	Lengh Low	DATA	ETX	BCC
-----	-----	-----	-----	-----	-----------------	-----------	------	-----	-----

DATA Structure

SL1 Authentication KEY
16 byte

Positive Response Packet

SOH	'E'	'0'	'4'	STX	'P'	STATUS	DATA Length High	Length Low	DATA	ETX	BCC
-----	-----	-----	-----	-----	-----	--------	---------------------	---------------	------	-----	-----

DATA Structure

The First byte is Status Code by Plus PICC(Refer to PLUS Datasheet). 0x90 is good status or Error code.

Status Code
1 byte

Negative Response Packet

SOH	'E'	'0'	'4'	STX	'N'	ST1	ST2	ETX	BCC
-----	-----	-----	-----	-----	-----	-----	-----	-----	-----

***You can use the Mifare Classic function. Please refer the Mifare Classic Part.**

7.16.4 “E05” : Level 2 Authentication.

This command is used to authenticate the security level2. Refer to PLUS Datasheet to get more command details.

Command Packet

SOH	'E'	'0'	'5'	STX	DATA Lengh High	Lengh Low	DATA	ETX	BCC
-----	-----	-----	-----	-----	-----------------	-----------	------	-----	-----

DATA Structure

Block Address	AES KEY
2byte (LSB First)	16 byte

Positive Response Packet

SOH	'E'	'0'	'5'	STX	'P'	STATUS	DATA Length High	Length Low	DATA	ETX	BCC
-----	-----	-----	-----	-----	-----	--------	---------------------	---------------	------	-----	-----

DATA Structure

The First byte is Status Code by Plus PICC(Refer to PLUS Datasheet). 0x90 is good status or Error code.

Status Code
1 byte

Negative Response Packet

SOH	'E'	'0'	'5'	STX	'N'	ST1	ST2	ETX	BCC
-----	-----	-----	-----	-----	-----	-----	-----	-----	-----

***After Authentication, you can use the Mifare Classic function. Please refer the Mifare Classic Part.**

Doc No	KYT6XXX Series SPECIFICATION	REV	PAGE	DATE
91000050		J	54 OF 63	2017.03 .20.

7.16.5 “E10” : Level 3 Authentication.

This command is used to authenticate each blocks. Refer to PLUS Datasheet to get more command details.

Command Packet

SOH	'E'	'1'	'0'	STX	DATA Lengh High	Lengh Low	DATA	ETX	BCC
-----	-----	-----	-----	-----	-----------------	-----------	------	-----	-----

DATA Structure

Block Address	AES KEY
2byte (LSB First)	16 byte

Positive Response Packet

SOH	'E'	'1'	'0'	STX	'P'	STATUS	DATA Lengh High	Length Low	DATA	ETX	BCC
-----	-----	-----	-----	-----	-----	--------	-----------------	------------	------	-----	-----

DATA Structure

The First byte is Status Code by Plus PICC(Refer to PLUS Datasheet). 0x90 is good status or Error code.

Status Code
1 byte

Negative Response Packet

SOH	'E'	'1'	'0'	STX	'N'	ST1	ST2	ETX	BCC
-----	-----	-----	-----	-----	-----	-----	-----	-----	-----

7.16.6 “E11” : Level 3 Follow Authentication.

This command is used to authenticate each blocks. Refer to PLUS Datasheet to get more command details.

Command Packet

SOH	'E'	'1'	'1'	STX	DATA Lengh High	Lengh Low	DATA	ETX	BCC
-----	-----	-----	-----	-----	-----------------	-----------	------	-----	-----

DATA Structure

Block Address	AES KEY
2byte (LSB First)	16 byte

Positive Response Packet

SOH	'E'	'1'	'1'	STX	'P'	STATUS	DATA Lengh High	Length Low	DATA	ETX	BCC
-----	-----	-----	-----	-----	-----	--------	-----------------	------------	------	-----	-----

DATA Structure

The First byte is Status Code by Plus PICC(Refer to PLUS Datasheet). 0x90 is good status or Error code.

Status Code
1 byte

Negative Response Packet

SOH	'E'	'1'	'1'	STX	'N'	ST1	ST2	ETX	BCC
-----	-----	-----	-----	-----	-----	-----	-----	-----	-----

Doc No	KYT6XXX Series SPECIFICATION	REV	PAGE	DATE
91000050		J	55 OF 63	2017.03 .20.

7.16.7 “E12” : Reset Authentication.

This command is used to reset the authentication. Refer to PLUS Datasheet to get more command details.

Command Packet

SOH	‘E’	‘1’	‘2’	STX	ETX	BCC
-----	-----	-----	-----	-----	-----	-----

Positive Response Packet

SOH	‘E’	‘1’	‘2’	STX	‘P’	STATUS	DATA Length High	Length Low	DATA	ETX	BCC
-----	-----	-----	-----	-----	-----	--------	------------------	------------	------	-----	-----

DATA Structure

The First byte is Status Code by Plus PICC(Refer to PLUS Datasheet). 0x90 is good status or Error code.

Status Code
1 byte

Negative Response Packet

SOH	‘E’	‘1’	‘2’	STX	‘N’	ST1	ST2	ETX	BCC
-----	-----	-----	-----	-----	-----	-----	-----	-----	-----

7.16.8 “E13” : Security Level3 Read Command.

This command is used to read the Card. Refer to PLUS Datasheet to get more

Command Packet

SOH	‘E’	‘1’	‘3’	STX	DATA Lengh High	Lengh Low	DATA	ETX	BCC
-----	-----	-----	-----	-----	-----------------	-----------	------	-----	-----

DATA Structure

Command Code(1byte)	Block Address	EXT (1byte)
0x00: 0x30h. 0x01: 0x31h. 0x02: 0x32h. 0x03: 0x33h. 0x04: 0x34h. 0x05: 0x35h. 0x06: 0x36h. 0x07: 0x37h.	2byte (LSB First)	0x01~0x08

Positive Response Packet

SOH	‘E’	‘1’	‘3’	STX	‘P’	STATUS	DATA Length High	Length Low	DATA	ETX	BCC
-----	-----	-----	-----	-----	-----	--------	------------------	------------	------	-----	-----

DATA Structure

The First byte is Status Code by Plus PICC(Refer to PLUS Datasheet). 0x90 is good status or Error code.

Status Code	Read Data	8byte MAC
1 byte	Max 256 byte	0byte or 8byte

* Regarding the MAC byte, it is decided to add the MAC byte by the Command code.

Negative Response Packet

SOH	‘E’	‘1’	‘3’	STX	‘N’	ST1	ST2	ETX	BCC
-----	-----	-----	-----	-----	-----	-----	-----	-----	-----

Doc No	KYT6XXX Series SPECIFICATION	REV	PAGE	DATE
91000050		J	56 OF 63	2017.03 .20.

7.16.8 “E14” : Security Level3 Write Command.

This command is used to write the Card. Refer to PLUS Datasheet to get more

Command Packet

SOH	'E'	'1'	'4'	STX	DATA Length High	Length Low	DATA	ETX	BCC
-----	-----	-----	-----	-----	------------------	------------	------	-----	-----

DATA Structure

Command Code(1byte)	Block Address	Write data
0x00: 0xA0h. 0x01: 0xA1h. 0x02: 0xA2h. 0x03: 0xA3h.	2byte (LSB First)	Max 48 byte

Positive Response Packet

SOH	'E'	'1'	'4'	STX	'P'	STATUS	DATA Length High	Length Low	DATA	ETX	BCC
-----	-----	-----	-----	-----	-----	--------	------------------	------------	------	-----	-----

DATA Structure

The First byte is Status Code by Plus PICC(Refer to PLUS Datasheet). 0x90 is good status or Error code.

Status Code	8byte MAC
1 byte	0 byte or 8byte.

*** Regarding the MAC byte, it is decided to add the MAC byte by the Command code.**

Negative Response Packet

SOH	'E'	'1'	'4'	STX	'N'	ST1	ST2	ETX	BCC
-----	-----	-----	-----	-----	-----	-----	-----	-----	-----

7.16.9 “E15” : Security Level3 Increment Command.

This command is used to increment the Value data. Refer to PLUS Datasheet to get more

Command Packet

SOH	'E'	'1'	'5'	STX	DATA Length High	Length Low	DATA	ETX	BCC
-----	-----	-----	-----	-----	------------------	------------	------	-----	-----

DATA Structure

*In case of the command code is 0x00(0xB0h) or 0x01(0xB1h)

Command Code(1byte)	Source Block Address	Write data
0x00: 0xB0h. 0x01: 0xB1h. 0x02: 0xB6h. 0x03: 0xB7h.	2byte (LSB First)	4 byte(LSB First)

*In case of the command code is 0x02(0xB6h) or 0x03(0xB7h)

Command Code(1byte)	Source Block Address	Target Block Address	Write data
0x00: 0xB0h. 0x01: 0xB1h. 0x02: 0xB6h. 0x03: 0xB7h.	2byte (LSB First)	2byte(LSB First)	4 byte(LSB First)

Positive Response Packet

SOH	'E'	'1'	'5'	STX	'P'	STATUS	DATA Length High	Length Low	DATA	ETX	BCC
-----	-----	-----	-----	-----	-----	--------	------------------	------------	------	-----	-----

Doc No	KYT6XXX Series SPECIFICATION	REV	PAGE	DATE
91000050		J	57 OF 63	2017.03 .20.

DATA Structure

The First byte is Status Code by Plus PICC(Refer to PLUS Datasheet). 0x90 is good status or Error code.

Status Code	8byte MAC
1 byte	0 byte or 8byte.

* Regarding the MAC byte, it is decided to add the MAC byte by the Command code.

Negative Response Packet

SOH	'E'	'1'	'5'	STX	'N'	ST1	ST2	ETX	BCC
-----	-----	-----	-----	-----	-----	-----	-----	-----	-----

7.16.10 "E16" : Security Level3 Decrement Command.

This command is used to Decrement the Value data. Refer to PLUS Datasheet to get more

Command Packet

SOH	'E'	'1'	'6'	STX	DATA Lengh High	Lengh Low	DATA	ETX	BCC
-----	-----	-----	-----	-----	-----------------	-----------	------	-----	-----

DATA Structure

*In case of the command code is 0x00(0xB2h) or 0x01(0xB3h)

Command Code(1byte)	Source Block Address	Write data
0x00: 0xB2h. 0x01: 0xB3h. 0x02: 0xB8h. 0x03: 0xB9h.	2byte (LSB First)	4 byte(LSB First)

*In case of the command code is 0x02(0xB8h) or 0x03(0xB9h)

Command Code(1byte)	Source Block Address	Target Block Address	Write data
0x00: 0xB2h. 0x01: 0xB3h. 0x02: 0xB8h. 0x03: 0xB9h.	2byte (LSB First)	2byte(LSB First)	4 byte(LSB First)

Positive Response Packet

SOH	'E'	'1'	'6'	STX	'P'	STATUS	DATA Length High	Length Low	DATA	ETX	BCC
-----	-----	-----	-----	-----	-----	--------	------------------	------------	------	-----	-----

DATA Structure

The First byte is Status Code by Plus PICC(Refer to PLUS Datasheet). 0x90 is good status or Error code.

Status Code	8byte MAC
1 byte	0 byte or 8byte.

* Regarding the MAC byte, it is decided to add the MAC byte by the Command code.

Negative Response Packet

SOH	'E'	'1'	'6'	STX	'N'	ST1	ST2	ETX	BCC
-----	-----	-----	-----	-----	-----	-----	-----	-----	-----

7.16.11 "E17" : Security Level3 Transfer Command.

This command stores the content of the Transfer Buffer to the specified address.

Refer to PLUS Datasheet to get more

Doc No	KYT6XXX Series SPECIFICATION	REV	PAGE	DATE
91000050		J	58 OF 63	2017.03 .20.

Command Packet

SOH	'E'	'1'	'7'	STX	DATA Lengh High	Lengh Low	DATA	ETX	BCC
-----	-----	-----	-----	-----	-----------------	-----------	------	-----	-----

DATA Structure

Command Code(1byte)	Dest. Block Address
0x00: 0xB4h. 0x01: 0xB5h.	2byte (LSB First)

Positive Response Packet

SOH	'E'	'1'	'7'	STX	'P'	STATUS	DATA Length High	Length Low	DATA	ETX	BCC
-----	-----	-----	-----	-----	-----	--------	------------------	------------	------	-----	-----

DATA Structure

The First byte is Status Code by Plus PICC(Refer to PLUS Datasheet). 0x90 is good status or Error code.

Status Code	8byte MAC
1 byte	0 byte or 8byte.

*** Regarding the MAC byte, it is decided to add the MAC byte by the Command code.**

Negative Response Packet

SOH	'E'	'1'	'7'	STX	'N'	ST1	ST2	ETX	BCC
-----	-----	-----	-----	-----	-----	-----	-----	-----	-----

7.16.12 "E18" : Security Level3 Transfer Command.

This command copies the content found in the Value Block at the given address to the Transfer Buffer.

Refer to PLUS Datasheet to get more

Command Packet

SOH	'E'	'1'	'8'	STX	DATA Lengh High	Lengh Low	DATA	ETX	BCC
-----	-----	-----	-----	-----	-----------------	-----------	------	-----	-----

DATA Structure

Command Code(1byte)	Source Block Address
0x00: 0xC2h. 0x01: 0xC3h.	2byte (LSB First)

Positive Response Packet

SOH	'E'	'1'	'8'	STX	'P'	STATUS	DATA Length High	Length Low	DATA	ETX	BCC
-----	-----	-----	-----	-----	-----	--------	------------------	------------	------	-----	-----

DATA Structure

The First byte is Status Code by Plus PICC(Refer to PLUS Datasheet). 0x90 is good status or Error code.

Status Code	8byte MAC
1 byte	0 byte or 8byte.

*** Regarding the MAC byte, it is decided to add the MAC byte by the Command code.**

Negative Response Packet

SOH	'E'	'1'	'8'	STX	'N'	ST1	ST2	ETX	BCC
-----	-----	-----	-----	-----	-----	-----	-----	-----	-----

Doc No	KYT6XXX Series SPECIFICATION	REV	PAGE	DATE
91000050		J	59 OF 63	2017.03 .20.

7.16.13 “E20” : Proximity Command

This command is carried out by measuring the round trip time of a challenge-response interaction..

Refer to PLUS Datasheet to get more

Command Packet

SOH	'E'	'2'	'0'	STX	DATA Lengh High	Lengh Low	DATA	ETX	BCC
-----	-----	-----	-----	-----	-----------------	-----------	------	-----	-----

DATA Structure

Proximity check key
16byte

Positive Response Packet

SOH	'E'	'2'	'0'	STX	'P'	STATUS	DATA Length High	Length Low	DATA	ETX	BCC
-----	-----	-----	-----	-----	-----	--------	------------------	------------	------	-----	-----

DATA Structure

The First byte is Status Code by Plus PICC(Refer to PLUS Datasheet). 0x90 is good status or Error code.

Status Code	MAC
1 byte	8byte.

Negative Response Packet

SOH	'E'	'2'	'0'	STX	'N'	ST1	ST2	ETX	BCC
-----	-----	-----	-----	-----	-----	-----	-----	-----	-----

Doc No	KYT6XXX Series SPECIFICATION	REV	PAGE	DATE
91000050		J	60 OF 63	2017.03 .20.

<Flow Chart>

1. Magnetic Card.

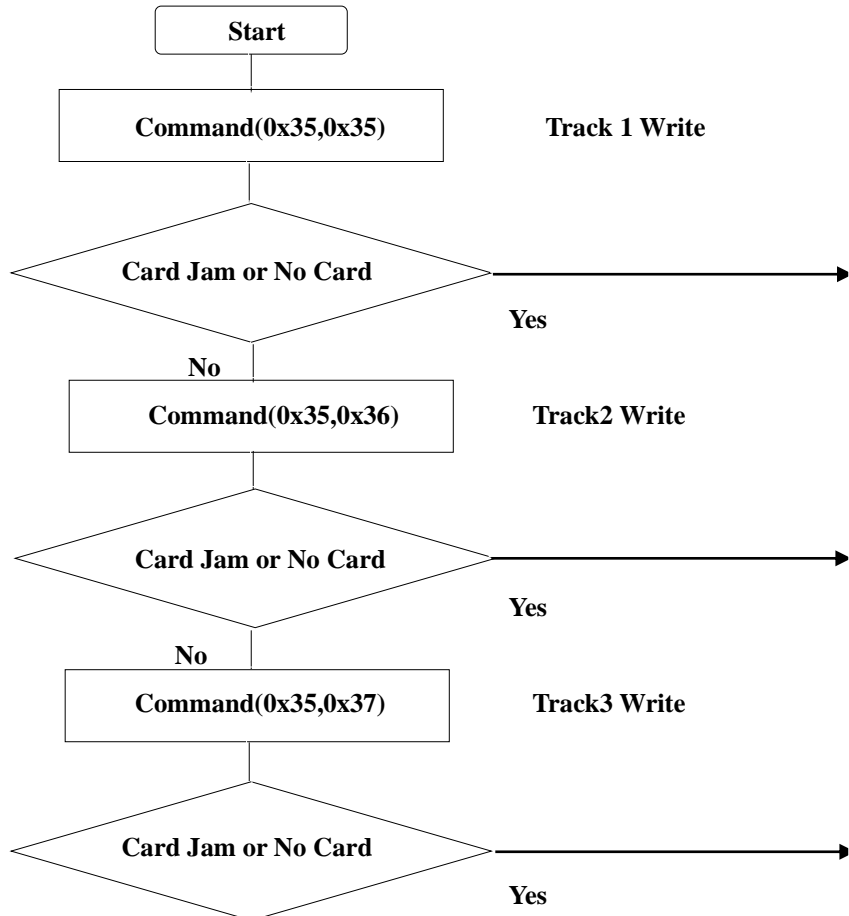

Doc No	KYT6XXX Series SPECIFICATION	REV	PAGE	DATE
91000050		J	61 OF 63	2017.03 .20.

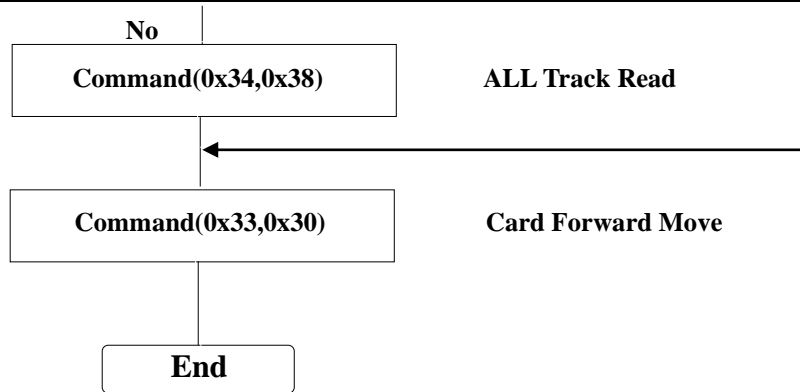

2. IC Card.

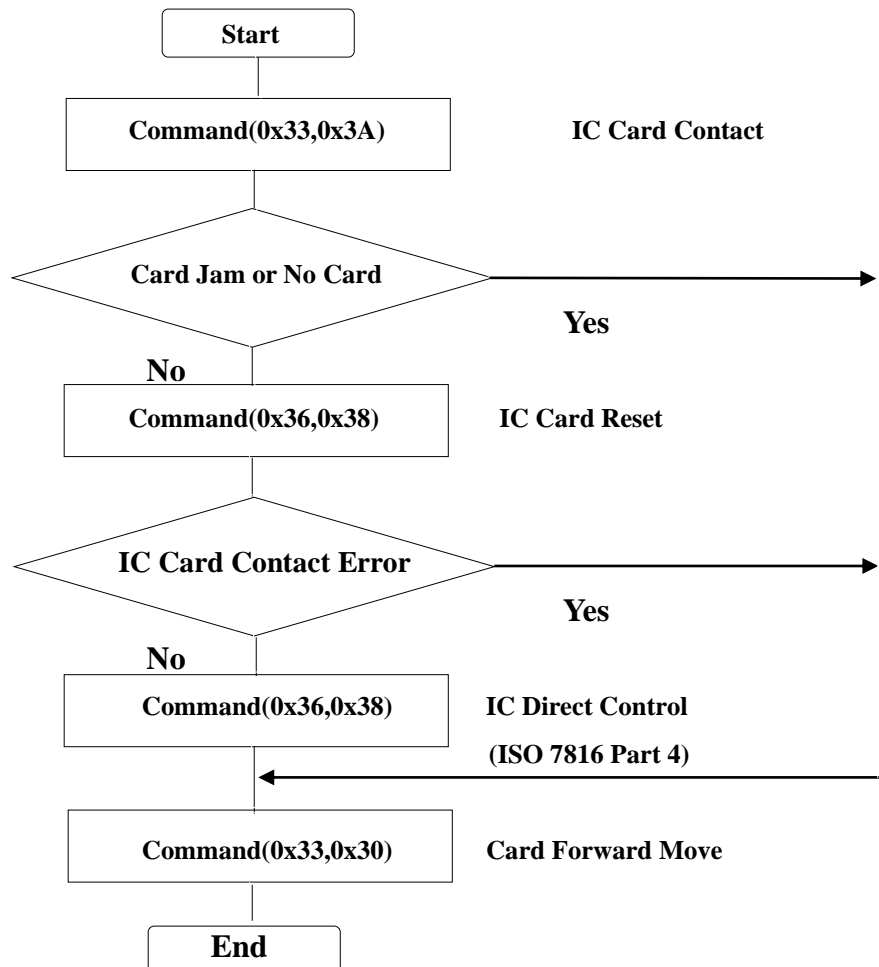

Doc No	KYT6XXX Series SPECIFICATION	REV	PAGE	DATE
91000050		J	62 OF 63	2017.03 .20.

Doc No	KYT6XXX Series SPECIFICATION	REV	PAGE	DATE
91000050		J	63 OF 63	2017.03 .20.

3. RF Card(Read).

